



GARMIN

CIRRUS PERSPECTIVE™



Cirrus SR20/SR22/SR22T
Integrated Avionics System
Cockpit Reference Guide

FLIGHT INSTRUMENTS

EIS

NAV/COM/TRANSPONDER/AUDIO PANEL

AUTOMATIC FLIGHT CONTROL SYSTEM

GPS NAVIGATION

FLIGHT PLANNING

PROCEDURES

HAZARD AVOIDANCE

ADDITIONAL FEATURES

ABNORMAL OPERATION

ANNUNCIATIONS & ALERTS

APPENDIX

INDEX

Copyright © 2008-2010 Garmin Ltd. or its subsidiaries. All rights reserved.

This manual reflects the operation of System Software version 0764.08 or later for the Cirrus SR20, SR22, and SR22T. Some differences in operation may be observed when comparing the information in this manual to earlier or later software versions.

Garmin International, Inc., 1200 East 151st Street, Olathe, Kansas 66062, U.S.A.
Tel: 913/397.8200 Fax: 913/397.8282

Garmin AT, Inc., 2345 Turner Road SE, Salem, OR 97302, U.S.A.
Tel: 503/391.3411 Fax 503/364.2138

Garmin (Europe) Ltd, Liberty House, Bulls Copse Road, Hounslow Business Park,
Southampton, SO40 9RB, U.K.
Tel: 44/0870.8501241 Fax: 44/0870.8501251

Garmin Corporation, No. 68, Jangshu 2nd Road, Shijr, Taipei County, Taiwan
Tel: 886/02.2642.9199 Fax: 886/02.2642.9099

For after-hours emergency, aircraft on ground (AOG) technical support for Garmin panel mount and integrated avionics systems, please contact Garmin's AOG Hotline at 913.397.0836.

Web Site Address: www.garmin.com

Except as expressly provided herein, no part of this manual may be reproduced, copied, transmitted, disseminated, downloaded or stored in any storage medium, for any purpose without the express written permission of Garmin. Garmin hereby grants permission to download a single copy of this manual and of any revision to this manual onto a hard drive or other electronic storage medium to be viewed for personal use, provided that such electronic or printed copy of this manual or revision must contain the complete text of this copyright notice and provided further that any unauthorized commercial distribution of this manual or any revision hereto is strictly prohibited.

Garmin® is a registered trademarks of Garmin Ltd. or its subsidiaries. FliteCharts® and SafeTaxi® are trademarks of Garmin Ltd. or its subsidiaries. These trademarks may not be used without the express permission of Garmin.

NavData® is a registered trademark of Jeppesen, Inc.; XM® is a registered trademark of XM Satellite Radio, Inc.



WARNING: Navigation and terrain separation must NOT be predicated upon the use of the terrain avoidance feature. The terrain avoidance feature is NOT intended to be used as a primary reference for terrain avoidance and does not relieve the pilot from the responsibility of being aware of surroundings during flight. The terrain avoidance feature is only to be used as an aid for terrain avoidance. Terrain data is obtained from third party sources. Garmin is not able to independently verify the accuracy of the terrain data.



WARNING: The displayed minimum safe altitudes (MSAs) are only advisory in nature and should not be relied upon as the sole source of obstacle and terrain avoidance information. Always refer to current aeronautical charts for appropriate minimum clearance altitudes.



WARNING: The altitude calculated by Perspective™ GPS receivers is geometric height above Mean Sea Level and could vary significantly from the altitude displayed by pressure altimeters, such as the Air Data Computer, or other altimeters in the aircraft. GPS altitude should never be used for vertical navigation. Always use pressure altitude displayed by the Perspective™ PFD or other pressure altimeters in aircraft.



WARNING: Do not use outdated database information. Databases used in the Perspective™ system must be updated regularly in order to ensure that the information remains current. Pilots using any outdated database do so entirely at their own risk.



WARNING: Do not use basemap (land and water data) information for primary navigation. Basemap data is intended only to supplement other approved navigation data sources and should be considered as an aid to enhance situational awareness.



WARNING: Traffic information shown on system displays is provided as an aid in visually acquiring traffic. Pilots must maneuver the aircraft based only upon ATC guidance or positive visual acquisition of conflicting traffic.



WARNING: XM Weather should not be used for hazardous weather penetration. Weather information provided by the GDL 69A is approved only for weather avoidance, not penetration.



WARNING: NEXRAD weather data is to be used for long-range planning purposes only. Due to inherent delays in data transmission and the relative age of the data, NEXRAD weather data should not be used for short-range weather avoidance.



WARNING: The Perspective™ system, as installed in the Cirrus SR20/SR22/SR22T aircraft, has a very high degree of functional integrity. However, the pilot must recognize that providing monitoring and/or self-test capability for all conceivable system failures is not practical. Although unlikely, it may be possible for erroneous operation to occur without a fault indication shown by the Perspective™ system. It is thus the responsibility of the pilot to detect such an occurrence by means of cross-checking with all redundant or correlated information available in the cockpit.



WARNING: For safety reasons, Perspective™ system operational procedures must be learned on the ground.



WARNING: The United States government operates the Global Positioning System and is solely responsible for its accuracy and maintenance. The GPS system is subject to changes which could affect the accuracy and performance of all GPS equipment. Portions of the Perspective™ system utilize GPS as a precision electronic NAVigation AID (NAVAID). Therefore, as with all NAVAIDs, information presented by the Perspective™ system can be misused or misinterpreted and, therefore, become unsafe.



WARNING: To reduce the risk of unsafe operation, carefully review and understand all aspects of the Perspective™ Pilot's Guide documentation and the Cirrus SR20/SR22/SR22T Airplane Flight Manual. Thoroughly practice basic operation prior to actual use. During flight operations, carefully compare indications from the Perspective™ system to all available navigation sources, including the information from other NAVAIDs, visual sightings, charts, etc. For safety purposes, always resolve any discrepancies before continuing navigation.



WARNING: The illustrations in this guide are only examples. Never use the Perspective™ system to attempt to penetrate a thunderstorm. Both the FAA Advisory Circular, Subject: Thunderstorms, and the Aeronautical Information Manual (AIM) recommend avoiding "by at least 20 miles any thunderstorm identified as severe or giving an intense radar echo."



WARNING: Lamp(s) inside this product may contain mercury (HG) and must be recycled or disposed of according to local, state, or federal laws. For more information, refer to our website at www.garmin.com/aboutGarmin/environment/disposal.jsp.



WARNING: Because of variation in the earth's magnetic field, operating the system within the following areas could result in loss of reliable attitude and heading indications. North of 72° North latitude at all longitudes. South of 70° South latitude at all longitudes. North of 65° North latitude between longitude 75° W and 120° W. (Northern Canada). North of 70° North latitude between longitude 70° W and 128° W. (Northern Canada). North of 70° North latitude between longitude 85° E and 114° E. (Northern Russia). South of 55° South latitude between longitude 120° E and 165° E. (Region south of Australia and New Zealand).



WARNING: Do not use GPS to navigate to any active waypoint identified as a 'NON WGS84 WPT' by a system message. 'NON WGS84 WPT' waypoints are derived from an unknown map reference datum that may be incompatible with the map reference datum used by GPS (known as WGS84) and may be positioned in error as displayed.



CAUTION: The PFD and MFD displays use a lens coated with a special anti-reflective coating that is very sensitive to skin oils, waxes, and abrasive cleaners. **CLEANERS CONTAINING AMMONIA WILL HARM THE ANTI-REFLECTIVE COATING.** It is very important to clean the lens using a clean, lint-free cloth and an eyeglass lens cleaner that is specified as safe for anti-reflective coatings.



CAUTION: The Perspective™ system does not contain any user-serviceable parts. Repairs should only be made by an authorized Garmin service center. Unauthorized repairs or modifications could void both the warranty and the pilot's authority to operate this device under FAA/FCC regulations.



NOTE: All visual depictions contained within this document, including screen images of the Perspective™ panel and displays, are subject to change and may not reflect the most current Perspective™ system and aviation databases. Depictions of equipment may differ slightly from the actual equipment.



NOTE: This device complies with part 15 of the FCC Rules. Operation is subject to the following two conditions: (1) this device may not cause harmful interference, and (2) this device must accept any interference received, including interference that may cause undesired operation.



NOTE: The data contained in the terrain and obstacle databases comes from government agencies. Garmin accurately processes and cross-validates the data, but cannot guarantee the accuracy and completeness of the data.



NOTE: This product, its packaging, and its components contain chemicals known to the State of California to cause cancer, birth defects, or reproductive harm. This notice is being provided in accordance with California's Proposition 65. If you have any questions or would like additional information, please refer to our web site at www.garmin.com/prop65.



NOTE: Interference from GPS repeaters operating inside nearby hangars can cause an intermittent loss of attitude and heading displays while the aircraft is on the ground. Moving the aircraft more than 100 yards away from the source of the interference should alleviate the condition.



NOTE: Use of polarized eyewear may cause the flight displays to appear dim or blank.



NOTE: The purpose of this Cockpit Reference Guide is to provide the pilot a resource with which to find operating instructions on the major features of the Perspective™ system more easily. It is not intended to be a comprehensive operating guide. Complete operating procedures for the system are found in the Perspective™ Pilot's Guide for this aircraft.

Blank Page

Part Number	Change Summary
190-00821-00 Rev A	Initial release
Rev B	Made clerical changes
Rev C	Made clerical changes to pages 8 and 91
190-00821-01	Added Enhanced Vision System Added changes in page navigation Added new procedures for creating user waypoints Added importing and exporting flight plans Updated Warning Alerts, Caution Alerts, and Advisory Annunciations Added new XM Weather product symbols Added other GDU 9.10 parameters
190-00821-02	Added SR20 engine display operation Added FIKI Anti-icing system GDU 9.12
190-00821-03	Added AOPA Airport Directory Added dual navigation database capability Added database synchronization Added GDU 10.00 parameters
190-00821-04	Added the SR22 Turbo Added GDU 11.00 parameters
190-00821-05	Added GTS 800 Traffic Advisory System Changed SR22 Turbo to SR22T

Revision	Date of Revision	Affected Pages	Description
A	April, 2010	All	Production release

Blank Page

- FLIGHT INSTRUMENTS** 1
 - Selecting the Altimeter Barometric Pressure Setting 1
 - Selecting Standard Barometric Pressure 1
 - Change Altimeter Barometric Pressure Setting Units 1
 - Change Navigation Sources 1
 - Enable/Disable OBS Mode While Navigating with GPS 1
 - Generic Timer 2
 - Configure V-speed Bugs 2
 - Set Barometric Minimum Descent Altitude 2
 - Displaying Wind Data 3

- ENGINE INDICATION SYSTEM** 5
 - Engine Page 6
 - System Display 11

- NAV/COM/TRANSPONDER/AUDIO PANEL** 13
 - DME Tuning 13
 - Enter a Transponder Code 13
 - Selecting a COM Radio 13
 - Selecting a NAV Radio 14
 - NAV/COM Tuning 14
 - Intercom System (ICS) Isolation 14
 - Digital Clearance Player 15

- AUTOMATIC FLIGHT CONTROL SYSTEM** 17
 - GFC 700 AFCS 17
 - S-TEC Fifty Five X Autopilot (Optional) 20

- GPS NAVIGATION** 21
 - Direct-to Navigation 21
 - Activate a Stored Flight Plan 22
 - Activate a Flight Plan Leg 22
 - Stop Navigating a Flight Plan 23
 - Vertical Navigation (VNAV) 23

- FLIGHT PLANNING** 27
 - Trip Planning 27
 - Create a New User Waypoint Defined by Latitude & Longitude 29
 - Create a New User Waypoint Defined by Radials from Other Waypoints 29
 - Create a New User Waypoint Defined by a Radial & Distance from Another Waypoint 31
 - Delete a User Waypoint 33
 - Create a New Flight Plan 33
 - Import a Flight Plan from an SD Card 34

Insert a Waypoint in the Active Flight Plan	35
Enter an Airway in a Flight Plan	36
Invert An Active Flight Plan	36
Remove a Departure, Arrival, Approach, or Airway from a Flight Plan	36
Store a Flight Plan	37
Edit a Stored Flight Plan	37
Delete a Waypoint from the Flight Plan	37
Invert and Activate a Stored Flight Plan	38
Copy a Flight Plan	38
Delete a Flight Plan	39
Graphical Flight Plan Creation	39
Export a Flight Plan to an SD Card	39
PROCEDURES	41
Load and Activate a Departure Procedure	41
Activate A Departure Leg	41
Load An Arrival Procedure	41
Activate An Arrival Leg	42
Load and/or Activate an Approach Procedure	42
Activate An Approach in the Active Flight Plan	43
Activate a Vector to Final Approach Fix	43
Activate A Missed Approach in the Active Flight Plan	44
HAZARD AVOIDANCE	45
Customizing the Hazard Displays on the Navigation Map	45
STORMSCOPE® (Optional)	45
XM Weather (Optional)	47
Traffic Advisory Systems	48
Terrain And Obstacle Proximity	50
Terrain-SVS	51
Terrain Awareness & Warning System (TAWS-B) Display	52
ADDITIONAL FEATURES	55
Synthetic Vision	55
Enhanced Vision System	56
Terminal Procedure Charts	57
AOPA Airport Directory	59
XM® Radio Entertainment	60
Electronic Checklists	62

ABNORMAL OPERATION	65
Reversionary Mode	65
Abnormal COM Operation	65
Hazard Displays with Loss of GPS Position	65
Unusual Attitudes	66
Dead Reckoning	67
ANNUNCIATIONS & ALERTS	69
WARNING Alerts	69
CAUTION Alerts	70
Advisory Annunciations	71
Comparator Annunciations	72
Reversionary Sensor Annunciations (SR22 Only)	72
Message Advisory Alerts	72
GFC 700 AFCS Alerts	73
Terrain-SVS Alerts	74
TAWS-B Alerts	75
Aural Alerts	78
CO Guardian Messages	78
MFD & PFD Message Advisories	79
Database Message Advisories	80
GMA 347 Message Advisories	82
GIA 63W Message Advisories	83
GEA 71 Message Advisories	86
GTX 32 & GTX 33 Message Advisories	86
GRS 77 Message Advisories	87
GMU 44 Message Advisories	88
GDL 69/69A Message Advisories	89
GDC 74A Message Advisories	89
GCU 478 Message Advisories	90
GMC 705 Message Advisories	90
GTS 800 Message Advisories	91
Miscellaneous Message Advisories	91
Flight Plan Import/Export Messages	95
APPENDIX	97
PFD Softkey Map	97
MFD Softkey Map	102
Loading Updated Databases	105
INDEX	Index-1

Blank Page

FLIGHT INSTRUMENTS

SELECTING THE ALTIMETER BAROMETRIC PRESSURE SETTING

Turn the **BARO** Knob to select the desired setting.

SELECTING STANDARD BAROMETRIC PRESSURE

Press the **BARO** Knob.

CHANGE ALTIMETER BAROMETRIC PRESSURE SETTING UNITS

- 1) Press the **PFD** Softkey to display the second-level softkeys.
- 2) Press the **ALT UNIT** Softkey.
- 3) Press the **IN** Softkey to display the barometric pressure setting in inches of mercury (in Hg).

Or:

Press the **HPA** Softkey to display the barometric pressure setting in hectopascals.

- 4) Press the **BACK** Softkey to return to the top-level softkeys.

CHANGE NAVIGATION SOURCES

- 1) Press the **CDI** Softkey to change from GPS to VOR1 or LOC1. This places the light blue tuning box over the NAV1 standby frequency in the upper left corner of the PFD.
- 2) Press the **CDI** Softkey again to change from VOR1 or LOC1 to VOR2 or LOC2. This places the light blue tuning box over the NAV2 standby frequency.
- 3) Press the **CDI** Softkey a third time to return to GPS.

ENABLE/DISABLE OBS MODE WHILE NAVIGATING WITH GPS

- 1) Press the **OBS** Softkey to select OBS Mode.
- 2) Turn a **CRS** Knob to select the desired course to/from the waypoint. Press the **CRS** Knob to synchronize the Selected Course with the bearing to the next waypoint.
- 3) Press the **OBS** Softkey again to disable OBS Mode.

GENERIC TIMER

- 1) Press the **TMR/REF** Softkey, then turn the large **FMS** Knob to select the time field (hh/mm/ss). Turn the **FMS** Knobs to set the desired time, then press the **ENT** Key. The UP/DOWN field is now highlighted.
- 2) Turn the small **FMS** Knob to display the UP/DOWN window. Turn the **FMS** Knob to select 'UP' or 'DOWN', then press the **ENT** Key. 'START?' is now highlighted.
- 3) Press the **ENT** Key to START, STOP, or RESET the timer (if the timer is counting DOWN, it will start counting UP after reaching zero). Press the **CLR** Key or the **TMR/REF** Softkey to remove the window.

CONFIGURE V-SPEED BUGS



NOTE: *V-speed values cannot be adjusted in all models.*

- 1) Press the **TMR/REF** Softkey.
- 2) Turn the large **FMS** Knob to highlight the desired V-speed.
- 3) Use the small **FMS** Knob to change the V-speed in 1-kt increments. Vx may be adjusted up to 89 knots and Vy may be adjusted down to 89 knots. Vglide and Vrotate cannot be adjusted. When a speed has been changed from a default value, an asterisk appears next to the value.
- 4) Press the **ENT** Key or turn the large **FMS** Knob to highlight the ON/OFF field
- 5) Turn the small **FMS** Knob clockwise to ON or counterclockwise to OFF.
- 6) To remove the window, press the **CLR** Key or the **TMR/REF** Softkey.

SET BAROMETRIC MINIMUM DESCENT ALTITUDE

- 1) Press the **TMR/REF** Softkey.
- 2) Turn the large **FMS** Knob to highlight the OFF/BARO field to the right of 'MINIMUMS'.
- 3) Turn the small **FMS** Knob clockwise to BARO.
- 4) Press the **ENT** Key.
- 5) Use the small **FMS** Knob to enter the desired altitude.

- 6) Press the **ENT** Key.
- 7) To remove the window, press the **CLR** Key or the **TMR/REF** Softkey.

DISPLAYING WIND DATA

- 1) Press the **PFD** Softkey.
- 2) Press the **WIND** Softkey to display wind data below the Selected Heading.
- 3) Press the **OPTN 1** or **OPTN 2** Softkey to change how wind data is displayed.
- 4) To remove the Wind Data Window, press the **OFF** Softkey.

- Flight Instruments
- EIS
- Nav/Com/XPDR/Audio
- AFCs
- GPS Nav
- Flight Planning
- Procedures
- Hazard Avoidance
- Additional Features
- Abnormal Operation
- Annun/Alerts
- Appendix
- Index

Blank Page

ENGINE INDICATION SYSTEM

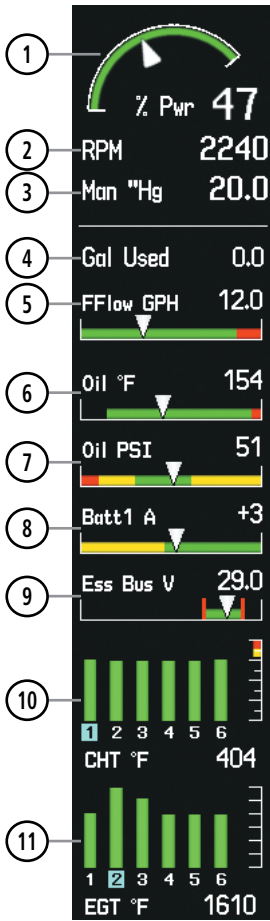

SR20

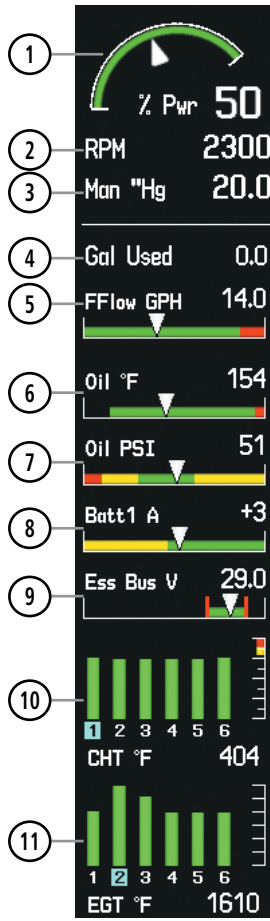

SR22

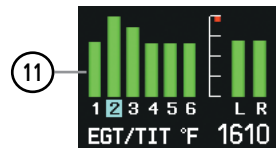

SR22T

- 1 Percent Power Indicator
- 2 Tachometer
- 3 Manifold Pressure
- 4 Gallons Used Indicator
- 5 Fuel Flow Indicator

- 6 Oil Temperature
- 7 Oil Pressure
- 8 Ammeter
- 9 Voltmeter
- 10 Cylinder Head Temperature

- 11 Exhaust Gas Temperature/Turbine Inlet Temperature (SR22T)
- 12 Target Cruise Power Fuel Flow

ENGINE PAGE

Pressing the **ENGINE** Softkey accesses the EIS - Engine Page, which displays all engine, fuel, fuel calculation, electrical, and air data information. Pressing the **FUEL** Softkey accesses the second-level softkeys.



(SR20)



(SR22)

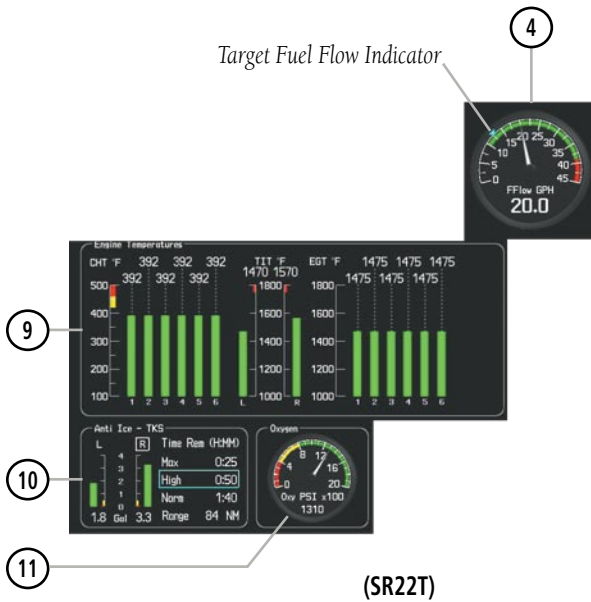

(SR22T)

- | | | |
|----------------------------|---------------------------|--|
| 1) Percent Power Indicator | 5) Oil Temperature | 9) Engine Temperature Group |
| 2) Tachometer | 6) Electrical Group | 10) TKS FIKI or TKS NH Fluid Quantity (optional) |
| 3) Manifold Pressure | 7) Fuel Calculation Group | 11) Oxygen Pressure |
| 4) Fuel Flow Indicator | 8) Air Data | |



NOTE: Fuel calculations do not use the aircraft fuel quantity indicators and are calculated from the last time the fuel was reset.

Adjusting the fuel totalizer quantity:

- 1) Press the **ENGINE** Softkey to display the Engine Page.
- 2) Press the **FUEL** Softkey to access the Initial Usable Fuel Page.
- 3) Turn the small **FMS** Knob increase or decrease the initial usable fuel displayed.

- Flight Instruments
- EIS
- Nav/Com/XPDR/Audio
- AFCs
- GPS Nav
- Flight Planning
- Procedures
- Hazard Avoidance
- Additional Features
- Abnormal Operation
- Annun/Alerts
- Appendix
- Index

Fuel Calculation		
Used	0.2 Gal	Calculated Fuel Used
Rem	91.8 Gal	
Time Rem	4:35 (H:MM)	Calculated Time Remaining
Range	460 NM	
Econ	5.0 NMPG	Calculated Economy

Set Fuel Remaining (points to Rem)
Calculated Range (points to Range)

Fuel Calculations Group



Full Fuel (SR20) Initial Usable Fuel Page



Fuel to TABS (SR22) Initial Usable Fuel Page

Leaning Assist Mode



NOTE: The pilot should follow the engine manufacturer's recommended leaning procedures in the Pilot's Operating Handbook (POH).

Accessing Leaning Assist Mode:

- 1) Press the **ENGINE** Softkey to display the Engine Page.
- 2) Press the **ASSIST** Softkey to identify peaks.

When the **ASSIST** Softkey is pressed, the system initially highlights the number and places a light blue box around the EGT readout of the cylinder with the hottest EGT. The Δ Peak temperature is the difference between the peak temperature and the present temperature for the peaked cylinder. When the first peak is detected, "1st" is announced below that cylinder's EGT bar and the temperature is enclosed in a light blue box.

The system continues to detect peak EGTs for each cylinder lean of peak as the fuel flow is decreased, and the peak of each cylinder's EGT is indicated by a light blue marker on the graph. Once all cylinders are lean of peak, the last cylinder to peak is denoted by the "Last" announcement below its bar on the graph.

Light Blue Box
Represents Peak

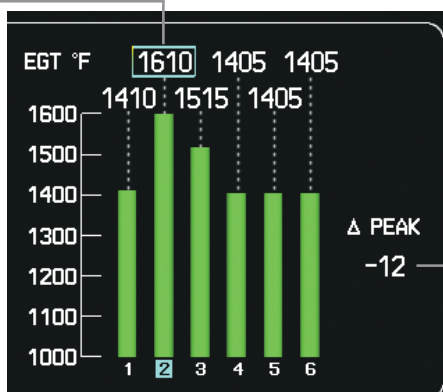

Temperature
Deviation
from Peak

Leaning Assist Mode

TKS FIKI Anti-ice System

In the default tank selection mode (AUTO), the system assures the fluid level in the two tanks is kept relatively even by periodically closing the tank with the lowest level. The system uses the TKS fluid tank quantity to control the tank shut-off valves. When the system is on and operating in AUTO mode, the shut-off valves close under the following conditions:

- The left and right tank level imbalance is greater than 0.25 gallons (low tank will be closed until level balance is within 0.15 gallons)
- The fluid quantity is empty (indicated from the fluid level sensor and level switch)
- The fluid quantity is unreliable (a miscompare between the level sensor and level switch or an out of range level sensor value)

Manual tank mode allows the pilot to control either tank's shut-off valve. Manual may be selected by pressing the **ANTI-ICE** Softkey to access the second-level softkeys **LEFT**, **AUTO**, and **RIGHT**.

- **LEFT** Softkey – opens left tank valve and closes right tank valve
- **AUTO** Softkey – returns to AUTO tank mode
- **RIGHT** Softkey – opens right tank valve and closes left tank valve

While operating in manual tank mode, only the selected/open tank's quantity is used for the range and endurance calculations.

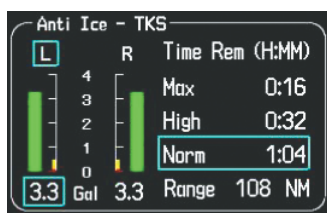

Manual Tank Mode (Left tank selected)

The TKS FIKI system consists of various operating modes, which are presented on the Perspective™ system. A white box highlights the active mode. Descriptions of the various modes are listed in the following table:

Operating Mode	System Operation	Comments
OFF	System Off	No modes selected
NORMAL	Both pumps operate on a timed, repeating cycle – 30 seconds ON and 90 seconds OFF	Provides 50% flow rate for light/moderate icing ☁
HIGH	A single primary pump (#1) operates continuously	Provides 100% flow rate for moderate icing ☁
MAX (momentary)	Both primary pumps operate continuously for 120 seconds	Provides 200% flow rate for severe icing or to expedite the removal of previous ice buildup ☁
PUMP BKUP	A single primary pump (#2) operates continuously	This mode is used in the event of a timer box failure or when BKUP mode is selected. Pump #2 provides 100% flow rate, bypassing the timer box ☁
☁ Refer to the AFM for pilot recommended actions		

SYSTEM DISPLAY



NOTE: Fuel calculations do not use the aircraft fuel quantity indicators and are calculated from the last time the fuel was reset.



NOTE: Refer to the Pilot's Operating Handbook (POH) for limitations.

Accessing the EIS System Display:

- 1) Press the **ENGINE** Softkey.
- 2) Press the **SYSTEM** Softkey.
- 3) To return to the default Engine Display, press the **ENGINE** or **BACK** Softkey.

- Flight Instruments
- EIS
- Nav/Com/XPDR/Audio
- AFCs
- GPS Nav
- Flight Planning
- Procedures
- Hazard Avoidance
- Additional Features
- Abnormal Operation
- Annun/Alerts
- Appendix
- Index

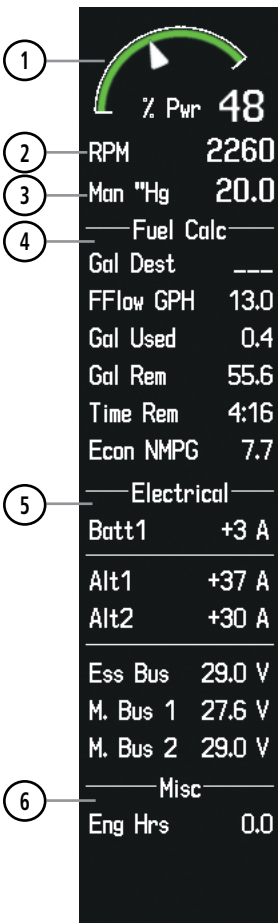

SR20

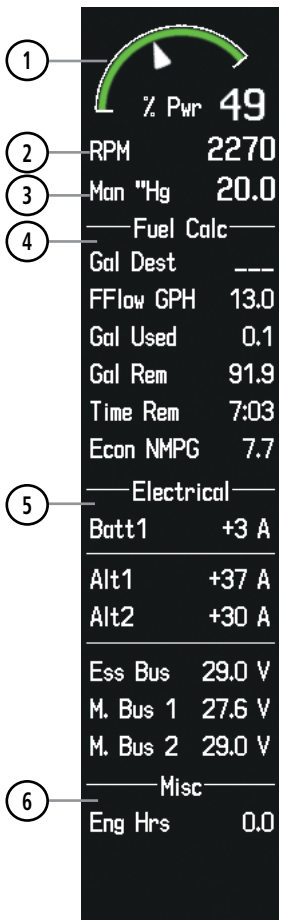

SR22

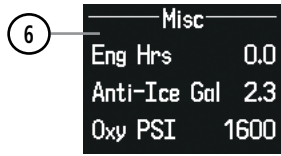

Optional Equipment

- 1 Percent Power Indicator
- 2 Tachometer
- 3 Manifold Pressure
- 4 Fuel Calculation Group

- 5 Electrical Group
- 6 Miscellaneous 'Anti-Ice Gal' and 'Oxy PSI' are optional on the SR22T

NAV/COM/TRANSPONDER/AUDIO PANEL

DME TUNING

- 1) Press the **DME** Softkey.
- 2) Turn the large **FMS** Knob to select the DME source field.
- 3) Turn the small **FMS** Knob to select the desired Nav radio.
- 4) Press the **ENT** Key to complete the selection.

ENTER A TRANSPONDER CODE

- 1) Press the **XPDR** Softkey to display the transponder mode selection softkeys.
- 2) Press the **CODE** Softkey to display the transponder code selection softkeys, for digit entry.
- 3) Press the digit softkeys to enter the code in the code field. When entering the code, the next key in sequence must be pressed within 10 seconds, or the entry is cancelled and restored to the previous code. Five seconds after the fourth digit has been entered, the transponder code becomes active.

Or:

- 1) Press the **XPDR** Key on the PFD/MFD Control Unit to select the transponder function.
- 2) Enter a Code with the Numeric Keypad or **FMS** Knob on the PFD/MFD Control Unit. Five seconds after the fourth digit has been entered, the transponder code becomes active.

SELECTING A COM RADIO

Transmit/Receive

Press the **COM1 MIC**, **COM2 MIC**, or **COM3 MIC** Key (optional COM radio, if installed) on the audio panel.

Receive Only

Press the **COM1**, **COM2**, or **COM3** Key (optional COM radio, if installed) on the audio panel.

SELECTING A NAV RADIO

- 1) To begin navigating using a navigation radio, press the **CDI** Softkey on the PFD to select VOR1/LOC1 (NAV1) or VOR2/LOC2 (NAV2).
- 2) Press the **NAV1**, **NAV2**, **DME**, or **ADF** Key on the audio panel to select or deselect the navigation radio audio source. All radio keys can be selected individually or together.

NAV/COM TUNING

- 1) Turn the respective tuning knobs to enter the desired frequency into the standby frequency field. The large knob enters MHz and the small knob enters kHz.
- 2) Press the appropriate **Frequency Transfer** Key to place the frequency into the active frequency field.
Or:
 - 1) Press the **COM** or **NAV** Key on the PFD/MFD Control Unit to select the desired COM or NAV frequency box.
 - 2) Turn the **FMS/XPDR COM/NAV** Knob to tune the desired frequency (large knob for MHz; small knob for kHz).
 - 3) Press the **Frequency Transfer** Key to transfer the frequency to the active field.

INTERCOM SYSTEM (ICS) ISOLATION

Press the **PILOT** and/or **COPLT** Key on the audio panel to select those isolated from hearing the Nav/Com radios and music.

PILOT KEY Annunciator	COPLT KEY Annunciator	Pilot Hears	Copilot Hears	Passenger Hears
OFF	OFF	Selected radios, aural alerts, pilot, copilot, passengers, music	Selected radios, aural alerts, pilot, copilot, passengers, music	Selected radios, aural alerts, pilot, copilot, passengers, music
ON	OFF	Selected radios, aural alerts, pilot	Copilot, passengers, music	Copilot, passengers, music
OFF	ON	Selected radios, aural alerts, pilot; passengers, music	Copilot	Selected radios, aural alerts, pilot, passengers, music
ON	ON	Selected radios, aural alerts, pilot, copilot	Selected radios, aural alerts, pilot, copilot	Passengers, music

ICS Isolation Modes

DIGITAL CLEARANCE PLAYER



NOTE: Only the audio for the selected **COM MIC** Key is recorded. Audio is not recorded for **COM3 MIC**.

- Pressing the **PLAY** Key once plays the latest recorded memory block, then returns to normal operation.
- Pressing the **MKR/MUTE** Key while playing a memory block stops play.
- Pressing the **PLAY** Key during play begins playing the previously recorded memory block. Each subsequent press of the **PLAY** Key begins playing the next previously recorded block.

- Flight Instruments
- EIS
- Nav/Com/XPDR/Audio**
- AFCs
- GPS Nav
- Flight Planning
- Procedures
- Hazard Avoidance
- Additional Features
- Abnormal Operation
- Annun/Alerts
- Appendix
- Index

Blank Page

AUTOMATIC FLIGHT CONTROL SYSTEM

GFC 700 AFCS



NOTE: If sensor information (other than attitude) required for a flight director mode becomes invalid or unavailable, the flight director automatically reverts to the default mode for that axis.



NOTE: If the attitude information required for the default flight director modes becomes invalid or unavailable, the autopilot automatically disengages.

Flight Director Activation

An initial press of a key listed in the following table (when the flight director is not active) activates the flight director in the listed modes.

Control Pressed	Modes Selected			
	Lateral		Vertical	
FD Key	Roll Hold (default)	ROL	Pitch Hold (default)	PIT
AP Key	Roll Hold (default)	ROL	Pitch Hold (default)	PIT
GA Switch	Go Around	GA	Go Around	GA
ALT Key	Roll Hold (default)	ROL	Altitude Hold	ALT
VS Key	Roll Hold (default)	ROL	Vertical Speed	VS
VNV Key	Roll Hold (default)	ROL	Vertical Path Tracking*	VPTH
NAV Key	Navigation**	GPS VOR LOC BC	Pitch Hold (default)	PIT
APR Key	Approach**	GPS VOR LOC	Pitch Hold (default) Glidepath Glideslope	PIT GP GS
HDG Key	Heading Select	HDG	Pitch Hold (default)	PIT
LVL Key	Level Hold	LVL	Level Hold	LVL

*Valid VNV flight plan must be entered before **VNV** Key press activates flight director.

The selected navigation receiver must have a valid VOR or LOC signal or active GPS course before **NAV or **APR** Key press activates flight director.

Vertical Modes

Vertical Mode	Description	Control	Annunciation
Pitch Hold	Holds the current aircraft pitch attitude; may be used to climb/descend to the Selected Altitude	(default)	PIT
Selected Altitude Armed	AFCS armed to capture the altitude displayed in the Selected Altitude window	*	ALTS
Altitude Hold	Holds the current Altitude Reference	ALT Key	ALT nnnn FT
Vertical Speed	Maintains the current aircraft vertical speed; may be used to climb/descend to the Selected Altitude	VS Key	VS nnnn FPM
VNAV	Captures and tracks the VNAV flight path	VNV Key	VPTH
VNAV Target Altitude Armed	AFCS armed to capture the altitude displayed in the VNAV Target Altitude window	**	ALTV
Glidepath	Captures and tracks the WAAS glidepath on approach	APR Key	GP
Glideslope	Captures and tracks the ILS glideslope on approach		GS
Takeoff	Commands constant pitch angle and wings level on ground in preparation for takeoff.	GA Switch	TO
Go Around	Disengages the autopilot and commands a constant pitch attitude and wings level		GA
Level Hold	Engages the autopilot (within engagement limits) and levels the aircraft in pitch and roll attitudes.	LVL Key	LVL

* *ALTS armed automatically when PIT, VS, or GA active, and under VPTH when Selected Altitude is to be captured instead of VNAV Target Altitude*

** *ALTV armed automatically under VPTH when VNAV Target Altitude is to be captured instead of Selected Altitude*

Lateral Modes

Lateral Mode	Description	Control	Annunciation
Roll Hold	Holds current aircraft roll attitude or rolls wings level, depending on commanded bank angle	(default)	ROL
Heading Select	Captures and tracks Selected Heading	HDG Key	HDG
Navigation, GPS Arm/Capture/Track	Captures and tracks selected navigation source (GPS, VOR, LOC)	NAV Key	GPS
Navigation, VOR Enroute Arm/Capture/Track			VOR
Navigation, LOC Arm/Capture/Track (No Glideslope)			LOC
Navigation Backcourse Capture/Track			BC
Approach, GPS Arm/Capture/Track	Captures and tracks selected navigation source (GPS, VOR, LOC)	APR Key	GPS
Approach, VOR Arm/Capture/Track			VAPP
Approach, ILS Arm/Capture/Track (Glideslope Mode automatically armed)			LOC
Takeoff	Commands constant pitch angle and wings level on ground in preparation for takeoff.	GA Switch	TO
Go Around	Disengages autopilot and commands a constant pitch angle and wings level		GA
Level Hold	Engages the autopilot and levels the aircraft in pitch and roll attitudes.	LVL Key	LVL

Level

Pressing the **LVL** Key engages the autopilot (within autopilot engagement limits) and levels the aircraft in pitch (to arrest a climb or descent) and roll. No other lateral or vertical modes are engaged, therefore, the aircraft will not hold a course or heading and will not hold a selected altitude.

S-TEC FIFTY FIVE X AUTOPILOT (OPTIONAL)



NOTE: *This status annunciation is not analogous to both Perspective™ and the S-TEC Fifty Five X. Refer to the approved S-TEC Fifty Five X Pilot's Operating Handbook (POH) for comprehensive list of annunciations and operating instructions.*

In addition to the status and mode annunciations that are simultaneously displayed on both the Perspective™ system AFCS Status Box and the S-TEC Fifty Five X Autopilot Display and/or Remote Annunciator Display, the Perspective™ system displays an additional status annunciation of 'AP' when the autopilot is engaged. This provides the pilot with a dedicated annunciation showing the status of the autopilot engagement.

GPS NAVIGATION

DIRECT-TO NAVIGATION

Direct-to Navigation using the MFD

- 1) Press the **Direct-to** () Key on the Control Unit.
- 2) Enter the waypoint identifier.
- 3) Press the **ENT** Key to confirm the identifier. The 'Activate?' field is highlighted.
- 4) If no altitude constraint or course is desired, press the **ENT** Key to activate. To enter an altitude constraint, proceed to step 5.
- 5) Turn the large **FMS** Knob to place the cursor over the 'VNV' altitude field.
- 6) Enter the desired altitude.
- 7) Press the **ENT** Key. If the waypoint entered is an airport, the option to select MSL or AGL is now displayed. If the waypoint is not an airport, proceed to step 9.
- 8) Turn the small **FMS** Knob to select 'MSL' or 'AGL'.
- 9) Press the **ENT** Key. The cursor is now flashing in the VNV offset distance field.
- 10) Enter the desired offset distance before (-) the waypoint.
- 11) Press the **ENT** Key. The 'Activate?' field is highlighted.
- 12) Press the **ENT** Key to activate.

Direct-to Navigation using the PFD

- 1) Press the **Direct-to** Key () on the PFD.
- 2) Turn the large **FMS** Knob to place the cursor in the desired selection field.
- 3) Turn the small **FMS** Knob to begin selecting the desired identifier, location, etc.
- 4) Press the **ENT** Key.
- 5) The cursor is now flashing on 'ACTIVATE?'. If no altitude constraint or course is desired, press the **ENT** Key to activate. To enter an altitude constraint, proceed to step 6.
- 6) Turn the large **FMS** Knob to place the cursor over the 'ALT' altitude field.

- 7) Turn the small **FMS** Knob to enter the desired altitude.
- 8) Press the **ENT** Key. If the waypoint entered is an airport, the option to select MSL or AGL is now displayed. If the waypoint is not an airport, proceed to step 10.
- 9) Turn the small **FMS** Knob to select 'MSL' or 'AGL'.
- 10) Press the **ENT** Key. The cursor is placed in the 'OFFSET' field.
- 11) Turn the small **FMS** Knob to enter the desired target altitude offset from the selected Direct-to.
- 12) Press the **ENT** Key to highlight 'Activate?' or turn the large **FMS** Knob to highlight the 'CRS' field.
- 13) Turn the small **FMS** Knob to enter the desired course to the waypoint.
- 14) Press the **ENT** Key to highlight 'ACTIVATE?'.
- 15) Press the **ENT** Key again to activate the Direct-to.

ACTIVATE A STORED FLIGHT PLAN

- 1) Press the **FPL** Key on the Control Unit and turn the small **FMS** Knob to display the Flight Plan Catalog Page.
- 2) Press the **FMS** Knob to activate the cursor.
- 3) Turn the large **FMS** Knob to highlight the desired flight plan
- 4) Press the **ACTIVE** Softkey. The confirmation window is now displayed.
- 5) With 'OK' highlighted, press the **ENT** Key to activate the flight plan. To cancel the flight plan activation, turn the large **FMS** Knob to highlight 'CANCEL' and press the **ENT** Key.

ACTIVATE A FLIGHT PLAN LEG

- 1) From the Active Flight Plan Page, press the **FMS** Knob to activate the cursor and turn the large **FMS** Knob to highlight the desired waypoint.
- 2) Press the **ACT LEG** Softkey.
OR
Press the **MENU** Key, select the 'Activate Leg' option from the page menu and press the **ENT** Key. This step must be used when activating a leg from the PFD.
- 3) With 'Activate' highlighted, press the **ENT** Key.

STOP NAVIGATING A FLIGHT PLAN

- 1) Press the **FPL** Key on the Control Unit to display the Active Flight Plan Page.
- 2) Press the **MENU** Key to display the Page Menu Window.
- 3) Turn the large **FMS** Knob to highlight 'Delete Flight Plan' and press the **ENT** Key. With 'OK' highlighted, press the **ENT** Key to deactivate the flight plan. This will not delete the stored flight plan, only the active flight plan.

VERTICAL NAVIGATION (VNAV)

The navigation database only contains altitudes for procedures that call for “Cross at” altitudes. If the procedure states “Expect to cross at,” the altitude is not in the database. In this case the altitude may be entered manually.

ACTIVE FLIGHT PLAN			
KIXD / KDFW			
	DTK	DIS	ALT
KARLA	221°	11.7NM	13000FT
COVIE	221°	9.0NM	12400FT
LEMYN	220°	8.0NM	9900FT
Approach - KDFW-RNAV 17L GPS LPV			
RIVET iaf	259°	18.8NM	4000FT
DRAAK	176°	3.3NM	2000FT
INWOD	176°	3.2NM	3000FT
MENOL faf	176°	3.9NM	<u>2300FT</u>
RW17L map	176°	5.3NM	
990FT	174°	0.8NM	990FT
POLKE			

5000FT Cross AT or ABOVE 5,000 ft

2300FT Cross AT 2,300 ft

3000FT Cross AT or BELOW 3,000 ft

- Flight Instruments
- EIS
- Nav/Com/XPDR/Audio
- AFCS
- GPS Nav
- Flight Planning
- Procedures
- Hazard Avoidance
- Additional Features
- Abnormal Operation
- Annun/Alerts
- Appendix
- Index

Altitudes associated with approach procedures are “auto-designated”. This means the system automatically uses the altitudes loaded with the approach for giving vertical flight path guidance outside the FAF. Note these altitudes are displayed as small light blue text.

Altitudes associated with arrival procedures are “manually-designated”. This means the system does not use the altitudes loaded with the arrival for giving vertical flight path guidance until designated to do so by the pilot. Note that these altitudes are initially displayed as white text. These altitudes may be “designated” by placing the cursor over the desired altitude and pressing the **ENT** Key. After designation, the text changes to light blue.

Altitudes that have been designated for use in vertical navigation may also be made “non-designated” by placing the cursor over the desired altitude and pressing the **CLR** Key. The altitude is now displayed only as a reference. It will not be used to give vertical flight path guidance. Other displayed altitudes may change due to re-calculations or rendered invalid as a result of manually changing an altitude to a non-designated altitude.

	White Text	Light Blue Text	Light Blue Subdued Text
Large Text	Altitude calculated by the system estimating the altitude of the aircraft as it passes over the navigation point. This altitude is provided as a reference and is not designated to be used in determining vertical flight path guidance.	Altitude has been entered by the pilot. Altitude is designated for use in giving vertical flight path. Altitude does not match the published altitude in navigation database or no published altitude exists.	The system cannot use this altitude in determining vertical flight path guidance.
Small Text	Altitude is not designated to be used in determining vertical flight path guidance. Altitude has been retrieved from the navigation database and is provided as a reference.	Altitude is designated for use in giving vertical flight path guidance. Altitude has been retrieved from the navigation database or has been entered by the pilot and matches a published altitude in the navigation database.	The system cannot use this altitude in determining vertical flight path guidance.

Flight Instruments

EIS

Nav/Com/XPDR/Audio

AFCs

GPS Nav

Flight Planning

Procedures

Hazard Avoidance

Additional Features

Abnormal Operation

Annun/Alerts

Appendix

Index

Blank Page

FLIGHT PLANNING

TRIP PLANNING

- 1) Turn the large **FMS** Knob on the Control Unit to select the 'AUX' page group.
- 2) Turn the small **FMS** Knob to select the Trip Planning Page.
- 3) The current 'PAGE MODE' is displayed at the top of the page: 'AUTOMATIC' or 'MANUAL'. To change the page mode, press the **AUTO** or **MANUAL** Softkey.
- 4) For Direct-to planning:
 - a) Press the **WPTS** Softkey and verify that the starting waypoint field indicates 'P.POS' (present position).
 - b) If necessary, press the **MENU** Key on the Control Unit and select 'Set WPT to Present Position' to display 'P.POS'.
 - c) Press the **ENT** Key and the flashing cursor moves to the ending waypoint field.
 - d) Enter the identifier of the ending waypoint and press the **ENT** Key to accept the waypoint.

Or:

For point-to-point planning:

- a) Enter the identifier of the starting waypoint.
- b) Once the waypoint's identifier is entered, press the **ENT** Key to accept the waypoint. The flashing cursor moves to the ending waypoint.
- c) Again, enter the identifier of the ending waypoint.
- d) Press the **ENT** Key to accept the waypoint.

Or:

For flight plan leg planning:

- a) Press the **FPL** Softkey (at the bottom of the display).
- b) Turn the small **FMS** Knob to select the desired flight plan (already stored in memory), by number.
- c) Turn the large **FMS** Knob to highlight the 'LEG' field.
- d) Turn the small **FMS** Knob to select the desired leg of the flight plan, or select 'CUM' to apply trip planning calculations to the entire flight plan.

Selecting 'FPL 00' displays the active flight plan. If an active flight plan is selected, 'REM' will be an available option to display planning data for the remainder of the flight plan.



NOTE: The page mode must be set to 'MANUAL' to perform the following steps.

- 5) Turn the large **FMS** Knob to highlight the departure time (DEP TIME) field.



NOTE: The departure time on the Trip Planning Page is used for preflight planning. Refer to the Utility Page for the actual flight departure time.

- 6) Enter the departure time. Press the **ENT** Key when finished. Departure time may be entered in local or UTC time, depending upon system settings.

- 7) The flashing cursor moves to the ground speed (GS) field. Enter the ground speed. Press the **ENT** Key when finished. Note that in 'automatic' page mode, ground speed is provided by the system.

- 8) The flashing cursor moves to the fuel flow field. Enter the fuel flow. Press the **ENT** Key when finished. Note that in 'AUTOMATIC' page mode, fuel flow is provided by the system.

- 9) The flashing cursor moves to the fuel onboard field. Enter the fuel onboard. Press the **ENT** Key when finished. Note that in 'AUTOMATIC' page mode, fuel onboard is provided by the fuel totalizer.

- 10) The flashing cursor moves to the calibrated airspeed (CALIBRATED AS) field. Enter the calibrated airspeed. Press the **ENT** Key when finished. Note that in 'AUTOMATIC' page mode, calibrated airspeed is provided by the system.

- 11) The flashing cursor moves to the altitude (IND ALTITUDE) field. Enter the altitude. Press the **ENT** Key when finished. Note that in 'AUTOMATIC' page mode, altitude is provided by the system.

- 12) The flashing cursor moves to the barometric setting (PRESSURE) field. Enter the desired baro setting. Press the **ENT** Key when finished. Note that in 'AUTOMATIC' page mode, the baro setting is provided by the setting entered on the PFD.

- 13) The flashing cursor moves to the air temperature (TOTAL AIR TEMP) field. Enter the desired air temperature. Press the **ENT** Key when finished. Note that in 'AUTOMATIC' page mode, air temperature is provided by the system outside air temperature.

CREATE A NEW USER WAYPOINT DEFINED BY LATITUDE & LONGITUDE

- 1) Turn the large **FMS** Knob on the Control Unit to select the 'WPT' page group.
- 2) Turn the small **FMS** Knob to select the User WPT Information Page.
- 3) Press the **NEW** Softkey. A waypoint is created at the current aircraft position.
- 4) Enter the desired waypoint name.
- 5) Press the **ENT** Key.
- 6) The cursor is now in the 'WAYPOINT TYPE' field. If desired, the waypoint can be made temporary (deleted automatically when the system is turned off). If the waypoint is to remain in the system, proceed to step 7.
 - a) Turn the large **FMS** Knob one click to the left to highlight 'TEMPORARY'.
 - b) Press the **ENT** Key to place a check-mark in the box. Turn the large **FMS** Knob to place the cursor back in the 'WAYPOINT TYPE' field.
- 7) With the cursor in the 'WAYPOINT TYPE' field, turn the small **FMS** Knob to display a list of waypoint types.
- 8) Turn the small **FMS** Knob to select LAT/LON (latitude and longitude).
- 9) Press the **ENT** Key.

CREATE A NEW USER WAYPOINT DEFINED BY RADIALS FROM OTHER WAYPOINTS

- 1) Turn the large **FMS** Knob on the Control Unit to select the 'WPT' page group.
- 2) Turn the small **FMS** Knob to select the User WPT Information Page.
- 3) Press the **NEW** Softkey. A waypoint is created at the current aircraft position.
- 4) Enter the desired waypoint name.
- 5) Press the **ENT** Key.
- 6) The cursor is now in the 'WAYPOINT TYPE' field. If desired, the waypoint can be made temporary (deleted automatically when the system is turned off). If the waypoint is to remain in the system, proceed to step 7.
 - a) Turn the large **FMS** Knob one click to the left to highlight 'TEMPORARY'.

- b) Press the **ENT** Key to place a check-mark in the box. Turn the large **FMS** Knob to place the cursor back in the 'WAYPOINT TYPE' field.
- 7) With the cursor in the 'WAYPOINT TYPE' field, turn the small **FMS** Knob to display a list of waypoint types.
- 8) Turn the small **FMS** Knob to select RAD/RAD (radial/radial).
- 9) Press the **ENT** Key.
- 10) The cursor moves to the 'REFERENCE WAYPOINTS' field. With the first waypoint name highlighted, use the **FMS** Knobs to enter the desired waypoint name. Waypoints may also be selected as follows:
- a) When a flight plan is active, turning the small **FMS** Knob to the left will display a list of the flight plan waypoints.
 - b) Turn the large **FMS** Knob to select the desired waypoint.
 - c) Press the **ENT** Key.
- Or:**
- a) Turn the small **FMS** Knob to the left. Initially, a flight plan waypoint list is displayed.
 - b) Turn the small **FMS** Knob to the right to display the 'NRST' airports to the aircraft's current position.
 - c) Turn the large **FMS** Knob to select the desired waypoint.
 - d) Press the **ENT** Key.
- Or:**
- a) Turn the small **FMS** Knob to the left. Initially, a flight plan waypoint list is displayed.
 - b) Turn the small **FMS** Knob to the right to display the 'RECENT' waypoints.
 - c) Turn the large **FMS** Knob to select the desired waypoint.
 - d) Press the **ENT** Key.
- Or:**
- a) Turn the small **FMS** Knob to the left. Initially, a flight plan waypoint list is displayed.
 - b) Turn the small **FMS** Knob to the right to display the 'USER' waypoints.
 - c) Turn the large **FMS** Knob to select the desired waypoint.
 - d) Press the **ENT** Key.

- 11) Press the **ENT** Key. The cursor is displayed in the 'RAD' (radial) field. Enter the desired radial from the reference waypoint.
- 12) Press the **ENT** Key.
- 13) Repeat step 10 to enter the next waypoint name.
- 14) Press the **ENT** Key. The cursor is displayed in the 'RAD' (radial) field for the second waypoint. Enter the desired radial from the reference waypoint.
- 15) Press the **ENT** Key.
- 16) Press the **FMS** Knob to remove the flashing cursor.

CREATE A NEW USER WAYPOINT DEFINED BY A RADIAL & DISTANCE FROM ANOTHER WAYPOINT

- 1) Turn the large **FMS** Knob on the Control Unit to select the 'WPT' page group.
- 2) Turn the small **FMS** Knob to select the User WPT Information Page.
- 3) Press the **NEW** Softkey. A waypoint is created at the current aircraft position.
- 4) Enter the desired waypoint name.
- 5) Press the **ENT** Key.
- 6) The cursor is now in the 'WAYPOINT TYPE' field. If desired, the waypoint can be made temporary (deleted automatically when the system is turned off). If the waypoint is to remain in the system, proceed to step 7.
 - a) Turn the large **FMS** Knob one click to the left to highlight 'TEMPORARY'.
 - b) Press the **ENT** Key to place a check-mark in the box. Turn the large **FMS** Knob to place the cursor back in the 'WAYPOINT TYPE' field.
- 7) With the cursor in the 'WAYPOINT TYPE' field, turn the small **FMS** Knob to display a list of waypoint types.
- 8) Turn the small **FMS** Knob to select RAD/DIS (radial/distance).
- 9) Press the **ENT** Key.
- 10) The cursor moves to the 'REFERENCE WAYPOINTS' field. With the first waypoint name highlighted, use the **FMS** Knobs to enter the desired waypoint name. Waypoints may also be selected as follows:
 - a) When a flight plan is active, turning the small **FMS** Knob to the left will display a list of the flight plan waypoints.

b) Turn the large **FMS** Knob to select the desired waypoint.

c) Press the **ENT** Key.

Or:

a) Turn the small **FMS** Knob to the left. Initially, a flight plan waypoint list is displayed.

b) Turn the small **FMS** Knob to the right to display the 'NRST' airports to the aircraft's current position.

c) Turn the large **FMS** Knob to select the desired waypoint.

d) Press the **ENT** Key.

Or:

a) Turn the small **FMS** Knob to the left. Initially, a flight plan waypoint list is displayed.

b) Turn the small **FMS** Knob to the right to display the 'RECENT' waypoints.

c) Turn the large **FMS** Knob to select the desired waypoint.

d) Press the **ENT** Key.

Or:

a) Turn the small **FMS** Knob to the left. Initially, a flight plan waypoint list is displayed.

b) Turn the small **FMS** Knob to the right to display the 'USER' waypoints.

c) Turn the large **FMS** Knob to select the desired waypoint.

d) Press the **ENT** Key.

11) Press the **ENT** Key. The cursor is displayed in the 'RAD' (radial) field. Enter the desired radial from the reference waypoint.

12) Press the **ENT** Key.

13) The cursor is now displayed in the 'DIS' (distance) field. Enter the desired distance from the reference waypoint.

14) Press the **ENT** Key.

15) Press the **FMS** Knob to remove the flashing cursor.

DELETE A USER WAYPOINT

- 1) Turn the large **FMS** Knob on the Control Unit to select the 'WPT' page group.
- 2) Turn the small **FMS** Knob to select the User WPT Information Page.
- 3) Press the **FMS** Knob to activate the cursor.
- 4) Turn the large **FMS** Knob to place the cursor in the 'USER WAYPOINT LIST' field.
- 5) Turn the small **FMS** Knob to highlight the desired waypoint.
- 6) Press the **DELETE** Softkey.
- 7) The message 'Would you like to delete the user waypoint?' is displayed. With 'YES' highlighted, press the **ENT** Key.

CREATE A NEW FLIGHT PLAN



NOTE: When creating a new flight plan in the Active Flight Plan Window, the first leg is activated automatically after it is created.

Creating an active flight plan:

- 1) Press the **FPL** Key.
- 2) Press the **FMS** Knob to activate the cursor (only on MFD).
- 3) Turn the small **FMS** Knob to display the Waypoint Information Window. (Turning it clockwise displays a blank Waypoint Information Window, turning it counter-clockwise displays the Waypoint Information Window with a waypoint selection submenu allowing selection of active flight plan, nearest, recent, user, or airway waypoints).
- 4) Enter the identifier, facility, or city name of the departure waypoint or select a waypoint from the submenu of waypoints and press the **ENT** Key. The active flight plan is modified as each waypoint is entered.
- 5) Repeat step numbers 3 and 4 to enter each additional flight plan waypoint.
- 6) When all waypoints have been entered, press the **FMS** Knob to remove the cursor.

Creating a stored flight plan:

- 1) Press the **FPL** Key.
- 2) Turn the small **FMS** Knob clockwise to display the Flight Plan Catalog Page.
- 3) Select the **NEW** Softkey; or press the **MENU** Key, highlight 'Create New Flight Plan', and press the **ENT** Key to display a blank flight plan for the first empty storage location.
- 4) Turn the small **FMS** Knob to display the Waypoint Information Window. (Turning it clockwise displays a blank Waypoint Information Window, turning it counter-clockwise displays the Waypoint Information Window with a waypoint selection submenu allowing selection of active flight plan, nearest, recent, user, or airway waypoints).
- 5) Enter the identifier, facility, or city name of the departure waypoint or select a waypoint from the submenu of waypoints and press the **ENT** Key.
- 6) Repeat step numbers 4 and 5 to enter each additional flight plan waypoint.
- 7) When all waypoints have been entered, press the **FMS** Knob to return to the Flight Plan Catalog Page. The new flight plan is now in the list.

IMPORT A FLIGHT PLAN FROM AN SD CARD



NOTE: See the *Annunciations & Alerts* section for flight plan import message descriptions.

- 1) Insert the SD card containing the flight plan in the top card slot on the MFD.
- 2) Press the **FPL** Key on the Control Unit to display the Active Flight Plan Page on the MFD.
- 3) Turn the small **FMS** Knob to select the Flight Plan Catalog Page.
- 4) Press the **FMS** Knob to activate the cursor.
- 5) Turn either **FMS** Knob to highlight an empty or existing flight plan.
- 6) Press the **IMPORT** Softkey.

If an empty flight plan is selected, a list of the available flight plans on the SD card will be displayed.

Or:

If an existing flight plan is selected, an 'Overwrite existing flight plan? OK or CANCEL' prompt is displayed. Press the **ENT** Key to choose to

overwrite the selected flight plan and see a list of the available flight plans on the SD card. If overwriting the existing flight plan is not desired, select 'CANCEL' using the **FMS** Knob, press the **ENT** Key, select another existing or empty flight plan, and again press the **IMPORT** Softkey.

- 7) Turn the small **FMS** Knob to highlight the desired flight plan for importing.
- 8) Press the **ENT** Key.

INSERT A WAYPOINT IN THE ACTIVE FLIGHT PLAN

- 1) Press the **FPL** Key on the Control Unit to display the active flight plan.
- 2) If necessary, press the **FMS** Knob to activate the cursor.
- 3) Turn the large **FMS** Knob to highlight the desired flight plan waypoint. The new waypoint is inserted before the highlighted waypoint.
- 4) Turn the small **FMS** Knob. The Waypoint Information Window is now displayed.
- 5) Enter the new flight plan waypoint by one of the following:
 - a) Enter the user waypoint identifier, facility, or city.
 - b) Press the **ENT** Key.
Or:
 - a) Turn the small **FMS** Knob to the left. Initially, a flight plan waypoint list is displayed.
 - b) Turn the small **FMS** Knob to the right to display the 'NRST' airport waypoints to the aircraft's current position.
 - c) Turn the large **FMS** Knob to select the desired waypoint.
 - d) Press the **ENT** Key.
Or:
 - a) Turn the small **FMS** Knob to the left. Initially, a flight plan waypoint list is displayed.
 - b) Turn the small **FMS** Knob to the right to display the 'RECENT' waypoints.
 - c) Turn the large **FMS** Knob to select the desired waypoint.
 - d) Press the **ENT** Key.
 - e) Press the **ENT** Key again to "accept" the waypoint.

ENTER AN AIRWAY IN A FLIGHT PLAN

- 1) Press the **FPL** Key on the Control Unit.
- 2) Press the **FMS** Knob to activate the cursor (not required on the PFD).
- 3) Turn the large **FMS** Knob to highlight the waypoint after the desired airway entry point. If this waypoint is not a valid airway entry point, a valid entry point should be entered at this time.
- 4) Turn the small **FMS** Knob one click clockwise and press the **LD AIRWY** Softkey, or press the **MENU** Key and select "Load Airway" (required on the PFD). The Select Airway Page is displayed. The **LD AIRWY** Softkey or the "Load Airway" menu item is available only when an acceptable airway entry waypoint has been chosen (the waypoint ahead of the cursor position).
- 5) Turn the **FMS** Knob to select the desired airway from the list, and press the **ENT** Key. Low altitude airways are shown first in the list, followed by "all" altitude airways, and then high altitude airways.
- 6) Turn the **FMS** Knob to select the desired airway exit point from the list, and press the **ENT** Key. 'LOAD?' is highlighted.
- 7) Press the **ENT** Key. The system returns to editing the flight plan with the new airway inserted.

INVERT AN ACTIVE FLIGHT PLAN

- 1) Press the **FPL** Key to display the active flight plan.
- 2) Press the **MENU** Key to display the Page Menu.
- 3) Turn the large **FMS** Knob to highlight 'Invert Flight Plan'.
- 4) Press the **ENT** Key. The original flight plan remains intact in its flight plan catalog storage location.
- 5) With 'OK' highlighted, press the **ENT** Key to invert the flight plan.

REMOVE A DEPARTURE, ARRIVAL, APPROACH, OR AIRWAY FROM A FLIGHT PLAN

- 1) Press the **FPL** Key to display the active flight plan. Press the **FMS** Knob to activate the cursor.

Or, for a stored flight plan:

- a) Press the **FPL** Key on the Control Unit and turn the small **FMS** Knob to select the Flight Plan Catalog Page.
 - b) Press the **FMS** Knob to activate the cursor.
 - c) Turn the large **FMS** Knob to highlight the desired flight plan.
 - d) Press the **EDIT** Softkey.
- 2) Turn the large **FMS** Knob to highlight the title for the approach, departure, arrival, or airway to be deleted. Titles appear in white directly above the procedure's waypoints.
 - 3) Press the **CLR** Key to display a confirmation window.
 - 4) With 'OK' highlighted, press the **ENT** Key to remove the selected procedure or airway.

STORE A FLIGHT PLAN

- 1) After creating a flight plan on either the PFD or MFD, it may be saved by pressing the **MENU** Key.
- 2) Turn the large **FMS** Knob to highlight 'Store Flight Plan' and press the **ENT** Key.
- 3) With 'OK' highlighted, press the **ENT** Key to store the flight plan.

EDIT A STORED FLIGHT PLAN

- 1) Press the **FPL** Key on the Control Unit and turn the small **FMS** Knob to display the Flight Plan Catalog Page.
- 2) Press the **FMS** Knob to activate the cursor.
- 3) Turn the large **FMS** Knob to highlight the desired flight plan.
- 4) Press the **EDIT** Softkey.
- 5) Turn the large **FMS** Knob to place the cursor in the desired location.
- 6) Enter the changes, then press the **ENT** Key.
- 7) Press the **FMS** Knob to return to the Flight Plan Catalog Page.

DELETE A WAYPOINT FROM THE FLIGHT PLAN

- 1) Press the **FPL** Key to display the active flight plan. Press the **FMS** Knob to activate the cursor.

Or, for a stored flight plan:

- a) Press the **FPL** Key on the Control Unit and turn the small **FMS** Knob to select the Flight Plan Catalog Page.

- b) Press the **FMS** Knob to activate the cursor.
 - c) Turn the large **FMS** Knob to highlight the desired flight plan.
 - d) Press the **EDIT** Softkey.
- 2) Turn the large **FMS** Knob to highlight the waypoint to be deleted.
 - 3) Press the **CLR** Key to display a 'REMOVE (Wpt Name)?' confirmation window.
 - 4) With 'OK' highlighted, press the **ENT** Key to remove the waypoint. To cancel the delete request, turn the large **FMS** Knob to highlight 'CANCEL' and press the **ENT** Key.
 - 5) Once all changes have been made, press the **FMS** Knob to remove the cursor.

INVERT AND ACTIVATE A STORED FLIGHT PLAN

- 1) Press the **FPL** Key on the Control Unit.
- 2) Turn the small **FMS** Knob to select the Flight Plan Catalog Page.
- 3) Press the **FMS** Knob to activate the cursor.
- 4) Turn the large **FMS** Knob to highlight the desired flight plan.
- 5) Press the **INVERT** Softkey. 'Invert and activate stored flight plan?' is displayed.
- 6) With 'OK' highlighted, press the **ENT** Key. The selected flight plan is now inverted and activated. The original flight plan remains intact in its flight plan catalog storage location.

COPY A FLIGHT PLAN

- 1) Press the **FPL** Key on the Control Unit.
- 2) Turn the small **FMS** Knob to select the Flight Plan Catalog Page.
- 3) Press the **FMS** Knob to activate the cursor.
- 4) Turn the large **FMS** Knob to highlight the flight plan to be copied.
- 5) Press the **COPY** Softkey. A 'Copy to flight plan #?' confirmation window is displayed.
- 6) With 'OK' highlighted, press the **ENT** Key to copy the flight plan. To cancel, turn the large **FMS** Knob to highlight 'CANCEL' and press the **ENT** Key.

DELETE A FLIGHT PLAN

- 1) Press the **FPL** Key on the Control Unit.
- 2) Turn the small **FMS** Knob to select the Flight Plan Catalog Page.
- 3) Press the **FMS** Knob to activate the cursor.
- 4) Turn the large **FMS** Knob to highlight the flight plan to be deleted.
- 5) Press the **DELETE** Softkey. A 'Delete flight plan #' confirmation window is displayed.
- 6) With 'OK' highlighted, press the **ENT** Key to delete the flight plan. To cancel, turn the large **FMS** Knob to highlight 'CANCEL' and press the **ENT** Key.

GRAPHICAL FLIGHT PLAN CREATION

- 1) Press the **FPL** Key on the Control Unit to display the Active Flight Plan Page on the MFD.
- 2) Press the **Joystick** to activate the map pointer. Use the **Joystick** to move the pointer to the desired point on the map to be inserted as a waypoint in the flight plan.
- 3) The default insertion point is at the end of the flight plan. If the selected waypoint is to be placed anywhere other than the end of the flight plan, press the **FMS** Knob to activate the cursor. Waypoints are inserted *ABOVE* the cursor. Turn the large **FMS** Knob to select the desired insertion point.
- 4) Press the **LD WPT** Softkey. The selected waypoint is inserted at the selected point. The default user waypoint naming is USR000, USR001, USR002, and so on.
- 5) To change the user waypoint name, follow the procedure for modifying a user waypoint.

EXPORT A FLIGHT PLAN TO AN SD CARD



NOTE: See the *Annunciations & Alerts* section for flight plan export message descriptions.

- 1) Insert the SD card into the top card slot on the MFD.
- 2) Press the **FPL** Key on the Control Unit to display the Active Flight Plan Page on the MFD.

- 3) Turn the small **FMS** Knob to select the Flight Plan Catalog Page.
- 4) Press the **FMS** Knob to activate the cursor.
- 5) Turn the large **FMS** Knob to highlight the flight plan to be exported.
- 6) Press the **EXPORT** Softkey.
- 7) Press the **ENT** Key to confirm the export.

PROCEDURES

LOAD AND ACTIVATE A DEPARTURE PROCEDURE

- 1) Press the **PROC** Key.
- 2) Turn the large **FMS** Knob to highlight 'SELECT DEPARTURE'.
- 3) Press the **ENT** Key. The cursor is displayed in the 'DEPARTURE' field with a list of available departures.
- 4) Turn the large **FMS** Knob to highlight the desired departure.
- 5) Press the **ENT** Key. A list of runways may be displayed for the departure. If so, turn either **FMS** Knob to select the desired runway.
- 6) Press the **ENT** Key. The cursor is displayed in the 'TRANSITION' field with a list of available transitions.
- 7) Turn the large **FMS** Knob to highlight the desired transition.
- 8) Press the **ENT** Key.
- 9) With 'LOAD?' highlighted, press the **ENT** Key. The departure is active when the flight plan is active.

ACTIVATE A DEPARTURE LEG

- 1) Press the **FPL** Key on the Control Unit to display the active flight plan.
- 2) Press the **FMS** Knob to activate the cursor.
- 3) Turn the large **FMS** Knob to highlight the TO waypoint of the desired leg within the departure.
- 4) Press the **ACT LEG** Softkey. A confirmation window showing the selected leg is displayed.
- 5) With 'ACTIVATE' highlighted, press the **ENT** Key.

LOAD AN ARRIVAL PROCEDURE

- 1) Press the **PROC** Key.
- 2) Turn the large **FMS** Knob to highlight 'SELECT ARRIVAL'.
- 3) Press the **ENT** Key. The cursor is displayed in the 'ARRIVAL' field with a list of available arrivals.

- 4) Turn the large **FMS** Knob to highlight the desired arrival.
- 5) Press the **ENT** Key. A list of transitions is displayed for the selected arrival.
- 6) Turn either **FMS** Knob to select the desired transition.
- 7) Press the **ENT** Key. A list of runways may be displayed for the selected arrival.
- 8) Turn the large **FMS** Knob to highlight the desired runway.
- 9) Press the **ENT** Key.
- 10) With 'LOAD?' highlighted, press the **ENT** Key.
- 11) The arrival becomes part of the active flight plan.

ACTIVATE AN ARRIVAL LEG

- 1) Press the **FPL** Key on the Control Unit to display the active flight plan.
- 2) Press the **FMS** Knob to activate the cursor.
- 3) Turn the large **FMS** Knob to highlight the TO waypoint of the desired leg within the arrival.
- 4) Press the **ACT LEG** Softkey. A confirmation window showing the selected leg is displayed.
- 5) With 'ACTIVATE' highlighted, press the **ENT** Key.

LOAD AND/OR ACTIVATE AN APPROACH PROCEDURE



NOTE: *If certain GPS parameters (WAAS, RAIM, etc.) are not available, some published approach procedures for the desired airport may not be displayed in the list of available approaches.*

- 1) Press the **PROC** Key.
- 2) Turn the large **FMS** Knob to highlight 'SELECT APPROACH'.
- 3) Press the **ENT** Key. A list of available approaches for the destination airport is displayed.
- 4) Turn either **FMS** Knob to highlight the desired approach.
- 5) Press the **ENT** Key. A list of available transitions for the selected approach procedure is now displayed.

- 6) Turn either **FMS** Knob to select the desired transition. The “Vectors” option assumes vectors will be received to the final course segment of the approach and will provide navigation guidance relative to the final approach course.
- 7) Press the **ENT** Key. The cursor moves to the MINIMUMS field.
- 8) If desired, the DA/MDA for the selected approach procedure may be entered and displayed on the PFD. Turn the small **FMS** Knob in the direction of the green arrow to change the display from OFF to BARO.
- 9) Press the **ENT** Key. The cursor moves to the altitude field. Turn the small **FMS** Knob to enter the published DA/MDA for the selected approach procedure.
- 10) Press the **ENT** Key. ‘LOAD? or ACTIVATE?’ is now displayed with ‘LOAD?’ highlighted.
- 11) Turn the large **FMS** Knob to select either ‘LOAD?’ or ‘ACTIVATE?’.
Selecting ‘LOAD?’ enters the selected approach procedure into the active flight plan, but is not currently active. Selecting ‘ACTIVATE?’ enters the selected approach procedure into the active flight plan and is immediately activated.
- 12) Press the **ENT** Key.

ACTIVATE AN APPROACH IN THE ACTIVE FLIGHT PLAN

- 1) Press the **PROC** Key.
- 2) Turn the large **FMS** Knob to highlight ‘ACTIVATE APPROACH’.
- 3) Press the **ENT** Key.

ACTIVATE A VECTOR TO FINAL APPROACH FIX

- 1) Press the **PROC** Key.
- 2) Turn the large **FMS** Knob to highlight ‘ACTIVATE VECTOR-TO-FINAL’.
- 3) Press the **ENT** Key.
- 4) The final approach course becomes the active leg.

ACTIVATE A MISSED APPROACH IN THE ACTIVE FLIGHT PLAN

- 1) Press the **PROC** Key.
- 2) Turn the large **FMS** Knob to highlight 'ACTIVATE MISSED APPROACH'.
- 3) Press the **ENT** Key. A confirmation window is displayed.
- 4) With 'ACTIVATE' highlighted, press the **ENT** Key.

Or:

Press the go-around button.

- 5) After activating the missed approach procedure, another approach procedure may be loaded.

HAZARD AVOIDANCE

CUSTOMIZING THE HAZARD DISPLAYS ON THE NAVIGATION MAP

- 1) With the Navigation Map Page displayed, press the **MENU** Key to display the Navigation Map Page Menu. The cursor flashes on the 'Map Setup' option.
- 2) Press the **ENT** Key. The Map Setup Menu is displayed. Turn the small **FMS** Knob to select 'Weather' to customize the display of weather features. Select 'Traffic' to customize the display of traffic.
- 3) Press the small **FMS** Knob to return to the Navigation Map Page.





STORMSCOPE® (OPTIONAL)



WARNING: *The Stormscope is not intended to be used for hazardous thunderstorm penetration. Weather information on the Perspective™ MFD is approved for weather avoidance only. Refer to the WX-500 Pilot's Guide for detailed operation.*

Displaying Stormscope Lightning Data on the Navigation Map Page

- 1) Press the **MAP** Softkey.
- 2) Press the **STRMSCP** Softkey. Press the **STRMSCP** Softkey again to remove Stormscope Lightning Data from the Navigation Map Page.

Lightning Age	Symbol
Strike is less than 6 seconds old	
Strike is between 6 and 60 seconds old	
Strike is between 1 and 2 minutes old	
Strike is between 2 and 3 minutes old	

Select 'Cell' or 'Strike' as the Stormscope Lightning Mode

- 1) Press the **MENU** Key (with the Navigation Map Page displayed).
- 2) Turn either **FMS** Knob to highlight 'Map Setup'.
- 3) Press the **ENT** Key.
- 4) Turn the small **FMS** Knob to highlight 'Weather'.

- 5) Press the **ENT** Key.
- 6) Turn the large **FMS** Knob to place the cursor in the 'STRMSCP MODE' field.
- 7) Turn the small **FMS** Knob to display the 'Cell/Strike' window.
- 8) Turn either **FMS** Knob to select 'Cell' or 'Strike'. Press the **ENT** Key.
- 9) Push the **FMS** Knob to return to the Navigation Map Page.

Clear Stormscope Lightning Data from the Navigation Map Page

- 1) Press the **MENU** Key (with the Navigation Map Page displayed).
- 2) Turn either **FMS** Knob to highlight the 'Clear Stormscope® Lightning' field and press the **ENT** Key.



NOTE: *If heading input is lost, strikes and/or cells must be cleared manually after the execution of each turn. This is to ensure that the strike and/or cell positions are depicted accurately in relation to the nose of the aircraft.*

Stormscope Page

- 1) Turn the large **FMS** Knob until the Map Page group is selected.
- 2) Turn the small **FMS** Knob select the Stormscope Page.

Change the Stormscope Lightning Mode Between 'Cell' and 'Strike'

- 1) Select the Stormscope Page.
- 2) Press the **MODE** Softkey. The **CELL** and **STRIKE** Softkeys are displayed. Press the **CELL** Softkey to display 'CELL' data or press the **STRIKE** Softkey to display 'STRIKE' data. 'CELL' or 'STRIKE' is displayed in the mode box located in the upper left corner of the Stormscope Page.



NOTE: *"Cell mode" uses a clustering program to identify clusters of electrical activity that indicate cells.*

Change the Viewing Mode Between 360° and 120°

- 1) Select the Stormscope Page.
- 2) Press the **VIEW** Softkey. The **360** and **ARC** Softkeys are displayed. Press the **360** Softkey to display a 360° viewing area or press the **ARC** Softkey to display a 120° viewing area.

Press the **CLEAR** Softkey to remove all Stormscope lightning data from the display.

XM WEATHER (OPTIONAL)



WARNING: Use of XM weather for hazardous weather penetration is not recommended. Weather information provided by XM Radio Service is approved only for weather avoidance, not penetration.

Displaying XM Weather on the Navigation Map Page

- 1) Press the **MAP** Softkey.
- 2) Press the **NEXRAD** and/or **XM LTNG** Softkey to display the desired weather. Press the applicable softkey again to remove weather data from the Navigation Map Page.

Display METAR and TAF information on the Airport Information Page

- 1) Turn the large **FMS** Knob to select the WPT Page Group.
- 2) Turn the small **FMS** Knob to select the Airport Information Page.
- 3) Press the **WX** Softkey to display METAR and TAF text (METAR and TAF information is updated every 12 minutes).

Displaying Weather on the Weather Data Link Page

- 1) Turn the large **FMS** Knob to select the Map Page Group.
- 2) Turn the small **FMS** Knob to select the Weather Data Link Page.
- 3) Press the available softkeys to select the desired XM weather product.
- 4) Press the **LEGEND** Softkey to view the legends for the selected products. If necessary, turn either **FMS** Knob to scroll through the list. Press the small **FMS** Knob or the **ENT** Key to return to the map.

Map Panning Information – Weather Data Link Page

- 1) Push in the **Joystick** to display the panning arrow.
- 2) Move the **Joystick** to place the panning arrow on AIRMETS, TFRs, METARs, SIGMETs, PIREPs or AIREPs.
- 3) Press the **ENT** Key to display pertinent information for the selected product.

Note that pressing the **ENT** Key when panning over an AIRMET or a SIGMET displays an information box that shows the text of the report. Panning over an airport with METAR information does not display more information but allows the user to press the **ENT** Key and select that Airport's Information Page to display the text of the report. Pressing the **ENT** Key when panning over a TFR displays TFR specific information.

Weather Products and Symbols

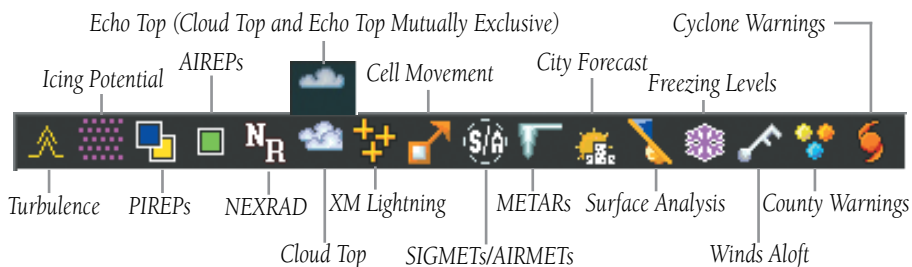

TRAFFIC ADVISORY SYSTEMS



WARNING: Traffic information shown on the Perspective™ Multi Function Display is provided as an aid in visually acquiring traffic. Pilots must maneuver the aircraft based only upon ATC guidance or positive visual acquisition of conflicting traffic.

Traffic Symbol	Description
	Non-Threat Traffic (intruder is beyond 5 nm and greater than 1200' vertical separation)
	Proximity Advisory (PA) (intruder is within 5 nm and less than 1200' vertical separation)
	Traffic Advisory (TA) (closing rate, distance, and vertical separation meet TA criteria)
	Traffic Advisory Off Scale

Traffic Symbol Description

Avidyne TAS600 Series Traffic Advisory System (Optional)

Displaying Traffic on the Traffic Map Page

- 1) Turn the large FMS Knob to select the Map Page Group.
- 2) Turn the small FMS Knob to select the Traffic Map Page.

- 3) Turn the **RANGE** Knob clockwise to display a larger area or counter-clockwise to display a smaller area.
- 5) Press the **MUTE** Softkey once to mute TAS voice alerts. Press twice rapidly to replay the last voice alert.

Displaying Traffic on the Navigation Map

- 1) Ensure TAS is operating.
- 2) With the Navigation Map displayed, press the **MAP** Softkey.
- 3) Press the **TRAFFIC** Softkey. Traffic is now displayed on the map.

GTS 800 (Optional)

System Self Test

- 1) Set the range to 2/6 nm.
- 2) Press the **STANDBY** Softkey.
- 3) Press the **TEST** Softkey.
- 4) Self test takes approximately eight seconds to complete. When completed successfully, traffic symbols display and a voice alert "Traffic Advisory System Test Passed" is heard. If the self test fails, the system reverts to Standby Mode and a voice alert "Traffic Advisory System Test Failed" is heard.

Enabling/Disabling Flight ID Display

On the Traffic Map Page, press the **FLT ID** Softkey.

Displaying Traffic on the Traffic Map Page

- 1) Turn the large **FMS** Knob to select the Map Page Group.
- 2) Turn the small **FMS** Knob to select the Traffic Map Page.
- 3) Press the **OPERATE** Softkey to begin displaying traffic. OPERATING is displayed in the Traffic mode field.
- 4) Press the **ALT MODE** Softkey to change the altitude volume.
- 5) Press the **STANDBY** Softkey to place the system in the Standby mode. STANDBY is displayed in the Traffic mode field.
- 6) Turn the **RANGE** Knob clockwise to display a larger area or counter-clockwise to display a smaller area.

Displaying Traffic on the Navigation Map

- 1) Ensure TAS is operating.
- 2) With the Navigation Map displayed, press the **MAP** Softkey.
- 3) Press the **TRAFFIC** Softkey. Traffic is now displayed on the map.

TERRAIN AND OBSTACLE PROXIMITY



NOTE: Terrain data is not displayed when the aircraft latitude is greater than 75 degrees north or 60 degrees south.

Displaying Terrain and Obstacles on the Terrain Proximity Page

- 1) Turn the large **FMS** Knob to select the Map Page Group.
- 2) Turn the small **FMS** Knob to select the Terrain Proximity Page.
- 3) If desired, press the **VIEW** Softkey to access the **ARC** and **360** Softkeys. When the **ARC** Softkey is pressed, a radar-like 120° view is displayed. Press the **360** Softkey to return to the 360° default display.
- 4) Rotate the **Joystick** clockwise to display a larger area or rotate counter-clockwise to display a smaller area.

Color	Terrain/Obstacle Location
Red	Terrain/Obstacle above or within 100' below current aircraft altitude.
Yellow	Terrain/Obstacle between 100' and 1000' below current aircraft altitude.
Black	Terrain/Obstacle is more than 1000' below aircraft altitude.

Displaying Terrain and Obstacles on the Navigation Map

- 1) With the Navigation Map displayed, press the **MAP** Softkey.
- 2) Press the **TERRAIN** Softkey. Terrain and obstacle proximity will now be displayed on the map.

TERRAIN-SVS



NOTE: Terrain-SVS is only available when the Synthetic Vision System (SVS) option is installed and the TAWS-B option has not been installed.



NOTE: Terrain data is not displayed when the aircraft latitude is greater than 75 degrees north or 60 degrees south.

Display Terrain on the TERRAIN-SVS Page

- 1) Turn the large **FMS** Knob to select the Map Page Group.
- 2) Turn the small **FMS** Knob to select the Terrain-SVS Page.
- 3) If desired, press the **VIEW** Softkey to access the **ARC** and **360** softkeys. When the **ARC** Softkey is selected, a radar-like 120° view is displayed. Press the **360** Softkey to return to the 360° default display.
- 4) Rotate the **Joystick** clockwise to display a larger area or rotate counter-clockwise to display a smaller area.

Color	Terrain/Obstacle Location
Red	Terrain/Obstacle above or within 100' below current aircraft altitude.
Yellow	Terrain/Obstacle between 100' and 1000' below current aircraft altitude.
Black	Terrain/Obstacle is more than 1000' below aircraft altitude.

Enable/Disable Aviation Data

- 1) While the Terrain-SVS Page is displayed, press the **MENU** Key.
- 2) Turn the small **FMS** Knob to select "Show (or Hide) Aviation Data".
- 3) Press the **ENT** Key.

Terrain-SVS Inhibit

Inhibit Terrain Alerting

While the Terrain-SVS Page is displayed, press the **INHIBIT** Softkey.

Or:

- 1) Press the **MENU** Key.
- 2) Turn the small **FMS** Knob to select 'Inhibit Terrain'.
- 3) Press the **ENT** Key.

Enable Terrain Alerting

While the Terrain-SVS Page is displayed, press the **INHIBIT** Softkey.

Or:

- 1) While the Terrain-SVS Page is displayed, press the **MENU** Key.
- 2) Turn the small **FMS** Knob to select 'Enable Terrain'.
- 3) Press the **ENT** Key.



NOTE: If Terrain-SVS alerts are inhibited when the Final Approach Fix is the active waypoint in a GPS WAAS approach, a **LOW ALT** annunciation may appear on the PFD next to the altimeter if the current aircraft altitude is at least 164 feet below the prescribed altitude at the Final Approach Fix.

TERRAIN AWARENESS & WARNING SYSTEM (TAWS-B) DISPLAY



WARNING: The TAWS display shows supplemental information only. It should not be used for navigation.



NOTE: Terrain data is not displayed when the aircraft latitude is greater than 75 degrees north or 60 degrees south.



NOTE: TAWS operation is only available when the Perspective™ system is configured for a TAWS-B installation.

Manual System Test

- 1) While the TAWS-B Page is displayed, press the **MENU** Key.
- 2) Turn the small **FMS** Knob to select 'Test TAWS System'.
- 3) Press the **ENT** Key. During the test 'TAWS TEST' is displayed in the center of the TAWS-B Page.

When all is in working order, a single aural chime is heard.

Display Terrain on the TAWS-B Page

- 1) Turn the large **FMS** Knob to select the Map Page Group.
- 2) Turn the small **FMS** Knob to select the TAWS-B Page.
- 3) If desired, press the **VIEW** Softkey to access the **ARC** and **360** softkeys. When the **ARC** Softkey is selected, a radar-like 120° view is displayed. Press the **360** Softkey to return to the 360° default display.
- 4) Rotate the **Joystick** clockwise to display a larger area or rotate counter-clockwise to display a smaller area.

Color	Terrain/Obstacle Location
Red	Terrain/Obstacle above or within 100' below current aircraft altitude.
Yellow	Terrain/Obstacle between 100' and 1000' below current aircraft altitude.
Black	Terrain/Obstacle is more than 1000' below aircraft altitude.

Enable/Disable Aviation Data

- 1) While the TAWS-B Page is displayed, press the **MENU** Key.
- 2) Turn the small **FMS** Knob to select "Show (or Hide) Aviation Data".
- 3) Press the **ENT** Key.

TAWS Inhibit



NOTE: If TAWS alerts are inhibited when the Final Approach Fix is the active waypoint in a GPS WAAS approach, a LOWALT annunciation may appear on the PFD next to the altimeter if the current aircraft altitude is at least 164 feet below the prescribed altitude at the Final Approach Fix.

Inhibit TAWS

While the TAWS-B Page is displayed, press the **INHIBIT** Softkey.

Or:

- 1) Press the **MENU** Key.
- 2) Turn the small **FMS** Knob to select 'Inhibit TAWS'.
- 3) Press the **ENT** Key.

Enable TAWS

While the TAWS-B Page is displayed, press the **INHIBIT** Softkey.

Or:

- 1) While the TAWS-B Page is displayed, press the **MENU** Key.
- 2) Turn the small **FMS** Knob to select 'Enable TAWS'.
- 3) Press the **ENT** Key.

ADDITIONAL FEATURES

SYNTHETIC VISION



WARNING: Use appropriate primary systems for navigation, and for terrain, obstacle, and traffic avoidance. SVS is intended as an aid to situational awareness only and may not provide the accuracy and/or fidelity upon which to solely base decisions and/or plan maneuvers to avoid terrain, obstacles, or traffic.



WARNING: Do not use SVS runway depiction as the sole means for determining the proximity of the aircraft to the runway or for maintaining the proper approach path angle during landing.

Synthetic Vision System (SVS) functionality is offered as an optional enhancement to the Perspective™ Integrated Avionics System.

SVS is primarily comprised of a computer-generated forward-looking, attitude aligned view of the topography immediately in front of the aircraft from the pilot's perspective. SVS information is shown on the primary flight display (PFD).

In addition to SVS enhancement to the PFD, the following features have been added to the PFD:

- Pathways
- Flight Path Marker
- Horizon Heading Marks
- Terrain and Obstacle Alerting
- Three-dimensional Traffic
- Airport Signs
- Runway Display

Displaying SVS Terrain

- 1) Press the **PFD** Softkey.
- 2) Press the **SYN VIS** Softkey.
- 3) Press the **SYN TERR** Softkey.
- 4) Press the **BACK** Softkey to return to the previous page.

Displaying Pathways

- 1) Press the **PFD** Softkey.
- 2) Press the **SYN VIS** Softkey.
- 3) If not already enabled, press the **SYN TERR** Softkey.
- 4) Press the **PATHWAY** Softkey.
- 5) Press the **BACK** Softkey to return to the previous page.

Displaying Heading on the Horizon

- 1) Press the **PFD** Softkey.
- 2) Press the **SYN VIS** Softkey.
- 3) If not already enabled, press the **SYN TERR** Softkey.
- 4) Press the **HRZN HDG** Softkey.
- 5) Press the **BACK** Softkey to return to the previous page.

Displaying Airport Signs

- 1) Press the **PFD** Softkey.
- 2) Press the **SYN VIS** Softkey.
- 3) If not already enabled, press the **SYN TERR** Softkey.
- 4) Press the **APTSIGNS** Softkey.
- 5) Press the **BACK** Softkey to return to the previous page.

ENHANCED VISION SYSTEM

The Perspective™ system provides a control and display interface to an Enhanced Vision System. EVS is designed to provide an aid to situational awareness while operating in low visibility environments.

Accessing the EVS System

- 1) Turn the large **FMS** Knob to select the AUX Page Group.
- 2) Turn the small **FMS** Knob to select the VIDEO Page.
- 3) Pressing the **VID ZM +** and **VID ZM -** softkeys switches the EVS display magnification between 1x and 2x.
- 4) Pressing the **HIDE MAP** Softkey removes the map from the display and increases the EVS display to full screen.

Adjusting the EVS Display

- 1) Turn the large **FMS** Knob to select the AUX Page Group.
- 2) Turn the small **FMS** Knob to select the VIDEO Page.
- 3) Press the **SETUP** Softkey. The EVS display adjustment softkeys are now displayed.
- 4) Pressing the **CNTRST -** and **CNTRST +** Softkeys adjust display contrast in five percent increments from 0 to 100%.
- 5) Pressing the **BRIGHT -** and **BRIGHT +** Softkeys adjust display brightness in five percent increments from 0 to 100%.
- 6) Pressing the **SAT -** and **SAT +** Softkeys adjust display saturation in five percent increments from 0 to 100%.
- 7) Pressing the **RESET** Softkey returns all video adjustments options to the default settings
- 8) Press the **BACK** Softkey to return to the previous softkey level, or after 45 seconds of softkey inactivity, the system reverts to the top level AUX - VIDEO Page softkeys.

TERMINAL PROCEDURE CHARTS



NOTE: *With the availability of SafeTaxi®, ChartView, or FliteCharts® in electronic form, it is still advisable to carry another source of charts on-board the aircraft.*

SafeTaxi®

SafeTaxi® is an enhanced feature that gives greater map detail as the map range is adjusted in on the airport. The airport display on the map reveals runways with numbers, taxiways identifiers, and airport landmarks including ramps, buildings, control towers, and other prominent features. Resolution is greater at lower map ranges. The aircraft symbol provides situational awareness while taxiing.

Pressing the **DCLTR** Softkey (declutter) once removes the taxiway markings and airport identification labels. Pressing the **DCLTR** Softkey twice removes VOR station ID, the VOR symbol, and intersection names if within the airport plan view. Pressing the **DCLTR** Softkey a third time removes the airport runway layout, unless the airport in view is part of an active route structure. Pressing the **DCLTR** Softkey again cycles back to the original map detail.

The SafeTaxi database contains detailed airport diagrams for selected airports. These diagrams provide the pilot with situational awareness by displaying the aircraft position in relation to taxiways, ramps, runways, terminals, and services. This information should not be used by the pilot as the basis for maneuvering the aircraft on the ground. This database is updated on a 56-day cycle.

ChartView

ChartView resembles the paper version of Jeppesen terminal procedures charts. The charts are displayed in full color with high-resolution. The MFD depiction shows the aircraft position on the moving map in the plan view of most approach charts and on airport diagrams.

The ChartView database is updated on a 14-day cycle. If the ChartView database is not updated within 70 days of the expiration date, ChartView will no longer function.

FliteCharts®

FliteCharts® resemble the paper version of AeroNav Services terminal procedures charts. The charts are displayed with high-resolution and in color for applicable charts. Current aircraft position is not displayed on FliteCharts.

The FliteCharts database contains procedure charts for the United States only. This database is updated on a 28-day cycle. If not updated within 180 days of the expiration date, FliteCharts will no longer function.

View Charts from the Navigation Map Page

- 1) Press the **SHW CHRT** Softkey when displayed.

Or:

Move the map pointer to point to a desired point on the map and press the **SHW CHRT** Softkey.

- 2) Select the **DP, STAR, APR, WX,** and **NOTAM** softkeys to access charts for departures, arrivals, approaches, weather and NOTAMS. Note that NOTAMS are only available with ChartView.
- 3) Press the **GO BACK** Softkey to return to the previous page.

View Charts from the Active Flight Plan Page

- 1) While viewing the Active Flight Plan Page, press the **FMS** Knob to activate the cursor.
- 2) Turn the large **FMS** Knob to select the departure airport, destination airport, departure, arrival, or approach.
- 3) Press the **SHW CHRT** Softkey. The appropriate chart is displayed, if available for the item selected.
- 4) Press the **GO BACK** Softkey to return to the previous page.

Change Day/Night View

- 1) While viewing a chart press the **MENU** Key to display the Page Menu OPTIONS.
- 2) Turn the large **FMS** Knob to highlight the 'Chart Setup' Menu Option and press the **ENT** Key.
- 3) Turn the large **FMS** Knob to move between the 'FULL SCREEN' and 'COLOR SCHEME' Options.
- 4) Turn the small **FMS** Knob to choose between the 'On' and 'Off' Full Screen Options.
- 5) Turn the small **FMS** Knob to choose between 'Day', 'Auto', and 'Night' Options.
- 6) In Auto Mode, turn the large **FMS** Knob to select the percentage field and change percentage with the small **FMS** Knob. The percentage of change is the day/night crossover point based on backlighting intensity.
- 7) Press the **FMS** Knob when finished to remove the Chart Setup Menu.

AOPA AIRPORT DIRECTORY

AOPA Airport Directory adds enhanced airport information when viewing airports on the WPT-Airport Information Page.

This database is updated four times per year. Check fly.garmin.com for the current database.

View Airport Directory Information

While viewing the WPT-Airport Information Page, if necessary, press the **INFO-1** Softkey to change the softkey label to display **INFO-2**. AOPA airport information is displayed on the right half of the display.

XM® RADIO ENTERTAINMENT

The XM® Radio Page provides information and control of the audio entertainment features of the XM Satellite Radio.

Selecting the XM Radio Page

- 1) Turn the large **FMS** Knob to select the Auxiliary Page Group.
- 2) Turn the small **FMS** Knob to select the XM Radio Page.
- 3) If necessary, press the **RADIO** Softkey to display the XM Radio Page where audio entertainment is controlled.

Active Channel and Channel List

The Active Channel Box on the XM Radio Page displays the currently selected channel. The Channels List Box of the XM Radio Page shows a list of the available channels for the selected category.

Selecting a Category

The Category Box of the XM Radio Page displays the currently selected category of audio.

- 1) Press the **CATGRY** Softkey on the XM Radio Page.
- 2) Press the **CAT +** and **CAT -** softkeys to cycle through the categories.

Or:

Turn the small **FMS** Knob to display the 'Categories' list. Highlight the desired category with the small **FMS** Knob.

- 3) Press the **ENT** Key.

Select an Available Channel within the Selected Category

- 1) While on the XM Radio Page, press the **CHNL** Softkey.
- 2) Press the **CH +** Softkey to go up through the list in the Channel Box, or move down the list with the **CH -** Softkey.

Or:

Press the **FMS** Knob to highlight the channel list and turn the large **FMS** Knob to scroll through the channels.

- 3) With the desired channel highlighted, press the **ENT** Key.

Entering a Channel Directly

- 1) While on the XM Radio Page, press the **CHNL** Softkey.
- 2) Press the **DIR CH** Softkey. The channel number in the Active Channel Box is highlighted.
- 3) Press the numbered softkeys located on the bottom of the display to directly select the desired channel number. The number keys on the PFD/MFD Control Unit may also be used.
- 4) Press the **ENT** Key to activate the selected channel.

Assigning Channel Presets

Up to 15 channels from any category can be assigned a preset number.

- 1) On the XM Radio Page, with the desired channel active, press the **PRESETS** Softkey to access the first five preset channels (**PS1 - PS5**).
- 2) Press the **MORE** Softkey to access the next five channels (**PS6 – PS10**), and again to access the last five channels (**PS11 – PS15**). Pressing the **MORE** Softkey repeatedly cycles through the preset channels.
- 3) Press any one of the (**PS1 - PS15**) softkeys to assign a number to the active channel.
- 4) Press the **SET** Softkey on the desired channel number to save the channel as a preset.

Adjusting Volume

- 1) With the XM Radio Page displayed, press the **VOL** Softkey.
- 2) Press the **VOL –** Softkey to reduce volume or press the **VOL +** Softkey to increase volume. (Once the **VOL** Softkey is pressed, the volume can also be adjusted using the small **FMS** Knob.)
- 3) Press the **MUTE** Softkey to mute the audio. Press the **MUTE** Softkey again to unmute the audio.

ELECTRONIC CHECKLISTS

The system accesses the checklists from an SD card inserted into the bezel slot. If the SD card contains an invalid checklist file or no checklist, the Power-up Page messages display 'Checklist File: Invalid' or 'Checklist File: N/A' (not available) and the **CHKLIST** Softkey is not available.

Accessing and Navigating Checklists

- 1) From any page on the MFD (except EIS Pages), press the **CHKLIST** Softkey.
- 2) Turn the large **FMS** Knob to select the 'GROUP' field.
- 3) Turn the small **FMS** Knob to select the desired procedure and press the **ENT** Key.
- 4) Turn the large **FMS** Knob to select the 'CHECKLIST' field.
- 5) Turn the **FMS** Knob to select the desired checklist and press the **ENT** Key. The selected checklist item is indicated with white text surrounded by a white box.
- 6) Press the **ENT** Key or **CHECK** Softkey to check the selected checklist item. The line item turns green and a checkmark is placed in the associated box. The next line item is automatically selected for checking.

Either **FMS** Knob can be used to scroll through the checklist and select the desired checklist item.

Press the **CLR** Key or **UNCHECK** Softkey to remove a check mark from an item.

- 7) When all checklist items have been checked, '*Checklist Finished*' is displayed in green text at the bottom left of the checklist window. If all items in the checklist have not been checked, '*CHECKLIST NOT FINISHED*' will be displayed in yellow text.
- 8) Press the **ENT** Key. 'GO TO NEXT CHECKLIST?' will be highlighted by the cursor.
- 9) Press the **ENT** Key to advance to the next checklist.
- 10) Press the **EXIT** Softkey to exit the Checklist Page and return to the page last viewed.

Immediately Accessing Emergency Procedures

- 1) From any page on the MFD, press the **CHKLIST** Softkey.
- 2) Press the **EMERGENCY** Softkey.
- 3) Turn the **FMS** Knob to select the desired emergency checklist and press the **ENT** Key.
- 4) Press the **ENT** Key or **CHECK** Softkey to check the selected emergency checklist item. The line item turns green and a checkmark is placed in the box next to it. The next line item is automatically highlighted for checking. Either **FMS** Knob can be used to scroll through the checklist and select the desired checklist item.
Press the **CLR** Key or **UNCHECK** Softkey to remove a check mark from an item.
- 5) When all checklist items have been checked, '*Checklist Finished*' is displayed in green text at the bottom left of the checklist window. If all items in the checklist have not been checked, '*CHECKLIST NOT FINISHED*' will be displayed in yellow text.
- 6) Press the **ENT** Key. 'GO TO NEXT CHECKLIST?' will be highlighted by the cursor.
- 7) Press the **ENT** Key to advance to the next checklist.
- 8) Press the **RETURN** Softkey to return to the previous checklist.
- 9) Press the **EXIT** Softkey to exit the Checklist Page and return to the page last viewed.

Flight Instruments

EIS

Nav/Com/XPDR/Audio

AFCs

GPS Nav

Flight Planning

Procedures

Hazard Avoidance

Additional Features

Abnormal Operation

Annun/Alerts

Appendix

Index

Blank Page

ABNORMAL OPERATION

REVERSIONARY MODE

Should a system detected failure occur in either display, the Perspective™ system automatically enters reversionary mode. In reversionary mode, critical flight instrumentation is combined with engine instrumentation on the remaining display.

Reversionary display mode can be manually activated by pressing the **DISPLAY BACKUP** Button on the instrument panel between the PFD and MFD.



NOTE: *The Cirrus SR20/SR22/SR22T Airplane Flight Manual (AFM) always takes precedence over the information found in this section.*

ABNORMAL COM OPERATION

When a COM tuning failure is detected by the system, the emergency frequency (121.500 MHz) is automatically loaded into the active frequency field of the COM radio for which the tuning failure was detected.

HAZARD DISPLAYS WITH LOSS OF GPS POSITION

If GPS position is lost, or becomes invalid, selected hazards being displayed on the Navigation Map Page are removed until GPS position is again established.



Loss of Hazard Functions with Loss of GPS Position

UNUSUAL ATTITUDES

The PFD ‘declutters’ when the aircraft enters an unusual attitude. Only the primary functions are displayed in these situations.

The following information is removed from the PFD (and corresponding softkeys are disabled) when the aircraft experiences unusual attitudes:

- Traffic Annunciations
- AFCS Annunciations
- Flight Director Command Bars
- Inset Map
- Temperatures
- DME Information Window
- Wind Data
- Selected Heading Box
- Selected Course Box
- Transponder Status Box
- System Time
- PFD Setup Menu
- Windows displayed in the lower right corner of the PFD:
 - Timer/References
 - Nearest Airports
 - Flight Plan
 - Messages
 - Procedures
- Barometric Minimum Descent Altitude Box
- Glideslope, Glidepath, and Vertical Deviation Indicators
- Altimeter Barometric Setting
- Selected Altitude
- VNV Target Altitude

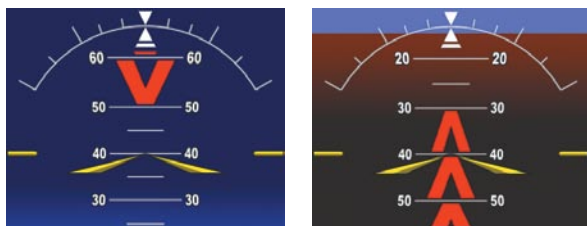

Extreme Pitch Indication

DEAD RECKONING

While in Enroute or Oceanic phase of flight, if the Perspective™ system detects an invalid GPS solution or is unable to calculate a GPS position, the system automatically reverts to Dead Reckoning (DR) Mode. In DR Mode, the system uses its last-known position combined with continuously updated airspeed and heading data (when available) to calculate and display the aircraft's current estimated position.



NOTE: *Dead Reckoning Mode only functions in Enroute (ENR) or Oceanic (OCN) phase of flight. In all other phases, an invalid GPS solution produces a "NO GPS POSITION" annunciation on the map and the system stops navigating in GPS Mode.*

DR Mode is indicated by the appearance of the letters 'DR' superimposed in yellow over the 'own aircraft' symbol as shown in the following figure. In addition, 'DR' is prominently displayed, also in yellow, on the HSI slightly above and to the right of the aircraft symbol on the CDI as shown in the following figure. Also, the CDI deviation bar is displayed in yellow. Lastly, but at the same time, a 'GPS NAV LOST' alert message appears on the PFD.

Normal navigation using GPS/WAAS source data resumes automatically once a valid GPS solution is restored.

It is important to note that estimated navigation data supplied by the system in DR Mode may become increasingly unreliable and must not be used as a sole means of navigation. If, while in DR Mode, airspeed and/or heading data is also lost or not available, the DR function may not be capable of estimating your position and, consequently, the system may display a path that is different than the actual movement of the aircraft. Estimated position information displayed by the system through DR while there is no heading and/or airspeed data available should not be used for navigation.

DR Mode is inherently less accurate than the standard GPS/WAAS Mode due to the lack of satellite measurements needed to determine a position. Changes in wind speed and/or wind direction compounds the relative inaccuracy of DR Mode. Because of this degraded accuracy, the crew must maintain position awareness using other navigation equipment until GPS-derived position data is restored.

- Flight Instruments
- EIS
- Nav/Com/XPDR/Audio
- AFCs
- GPS Nav
- Flight Planning
- Procedures
- Hazard Avoidance
- Additional Features
- Abnormal Operation
- Annun/Alerts
- Appendix
- Index



CDI 'DR' Indication on PFD



Symbolic Aircraft
(Map pages and Inset Map)

Dead Reckoning Indications

As a result of operating in DR Mode, all GPS-derived data is computed based upon an estimated position and is displayed as yellow text on the display to denote degraded navigation source information. This data includes the following:

- Navigation Status Box fields except Active Leg, TAS, and DTK
- Course Deviation Indicator
- GPS Bearing Pointer
- Wind data and pointers in the Wind Data Box on the PFD
- Track Indicator
- All Bearing Pointer Distances
- Active Flight Plan distances, bearings, and ETE values

Also, while the system is in DR Mode, the autopilot will not couple to GPS, and Terrain Proximity, TERRAIN-SVS, and TAWS are disabled. Additionally, the accuracy of all nearest information (airports, airspaces, and waypoints) is questionable. Finally, airspace alerts continue to function, but with degraded accuracy.

ANNUNCIATIONS & ALERTS

WARNING ALERTS



Annunciation Window Text	Alerts Window Text	Audio Alert
ANTI ICE CTL ☁	Tank valves cannot be controlled (closed) (TKS).	Repeating Double Chime
ANTI ICE FLOW ☁	Flow rate is low (TKS).	Repeating Double Chime
ANTI ICE QTY ☁	Left and right fluid quantities are unknown (TKS)	Repeating Double Chime
ANTI ICE QTY ☁☁	Fluid quantity is low (TKS).	Repeating Double Chime
AOA OVERHEAT ☁	AOA probe is overheated.	Repeating Double Chime
BRAKE TEMP	Brake temperature is high.	Repeating Double Chime
CHT	Cylinder head temperature is high.	Repeating Double Chime
CO LVL HIGH	Carbon monoxide level is too high.	Repeating Double Chime
ESS BUS	Check essential power bus voltage.	Repeating Double Chime ¹
FUEL FLOW *	Check fuel flow.	None
FUEL QTY	Check fuel tank levels.	Repeating Double Chime
M BUS 1	Check main power bus 1 voltage.	Repeating Double Chime
M BUS 2	Check main power bus 2 voltage.	Repeating Double Chime
MAN PRESSURE *	Check manifold pressure.	Repeating Double Chime (after 30 seconds)
OIL PRESSURE	Oil pressure is out of range.	Repeating Double Chime ¹
OIL TEMP	Oil temperature is high.	Repeating Double Chime
OXYGEN FAULT ⁺	Oxygen system fault.	Repeating Double Chime
OXYGEN QTY ⁺	Oxygen quantity is low.	Repeating Double Chime
RPM	Check engine RPM.	Repeating Double Chime
STALL	Stall warning.	Tone
START ENGAGED	Starter is engaged.	Repeating Double Chime
TIT *	TIT temperature is high.	Repeating Double Chime

✦ Optional / * Not applicable to all models / ☁ TKS NH (optional) / ☁ TKS FIKI (optional) / ¹ In air only



- Flight Instruments
- EIS
- Nav/Com/XPDR/Audio
- AFCS
- GPS Nav
- Flight Planning
- Procedures
- Hazard Avoidance
- Additional Features
- Abnormal Operation
- Annun/Alerts
- Appendix
- Index

CAUTION ALERTS

	Annunciation Window Text	Alerts Window Text	Audio Alert
Flight Instruments	ALT 1	Check alternator 1 current.	Double Chime ¹
EIS	ALT 2	Check alternator 2 current.	Double Chime ¹
Nav/Com/XPDR/Audio	ALT AIR OPEN*	Alternate air door is open.	Double Chime
AFCs	ANTI ICE HEAT ☁	Stall warning/AoA heater has failed.	Double Chime
GPS Nav	ANTI ICE LEVEL ☁	Left tank fluid quantity is unreliable (TKS).	Double Chime
	ANTI ICE LEVEL ☁	Right tank fluid quantity is unreliable (TKS).	Double Chime
	ANTI ICE PRESS ☁	Tail pressure is low (TKS).	Double Chime
	ANTI ICE PRESS ☁	Pressure is high (TKS).	Double Chime
	ANTI ICE QTY ☁	Fluid quantity imbalance has been detected (TKS)	Double Chime
Flight Planning	ANTI ICE QTY ☁ ☁	Fluid quantity is low (TKS)	Double Chime
Procedures	ANTI ICE SPEED ☁	Airspeed is too low for ice protection (TKS).	Double Chime ¹
	ANTI ICE SPEED ☁	Airspeed is to high for ice protection (TKS).	Double Chime ¹
Hazard Avoidance	AP MISCOMPARE ⁺	Autopilot miscompare, autopilot is not available.	Double Chime
	AP/PFD DIF ADC ⁺	Autopilot and PFD are using different ADCs.	Double Chime
	AP/PFD DIF AHRS ⁺	Autopilot and PFD are using different AHRSs.	Double Chime
Additional Features	AVIONICS OFF	Avionics master switch is off.	Double Chime
	BATT 1	Check battery 1 current.	Double Chime ¹
Abnormal Operation	BRAKE TEMP	Brake temperature is high.	Double Chime
	CHT	Cylinder head temperature is high.	Double Chime
	FLAP OVERSPEED	Flaps are extended beyond airspeed limitations.	Double Chime
Annun/Alerts	FUEL FILTER	Fuel filter in bypass	Double Chime
	FUEL QTY	Check fuel tank levels.	Double Chime
Appendix	M BUS 1	Check main power bus 1.	Double Chime ¹
	M BUS 2	Check main power bus 2.	Double Chime ¹
	MAN PRESSURE*	Check manifold pressure.	None
Index	NO ADC MODES ⁺	Autopilot air data modes are not available.	Double Chime
	NO VERT MODES ⁺	Autopilot vertical modes are not available.	Double Chime
	OIL PRESSURE	Oil pressure is out of range.	Double Chime ¹

Annunciation Window Text	Alerts Window Text	Audio Alert
OIL TEMP	Oil temperature is high.	Double Chime
OXYGEN QTY⁺	Oxygen quantity is low.	Double Chime
OXYGEN RQD⁺	Oxygen is required.	Double Chime
PARK BRAKE	Parking break is set.	None
PITOT HEAT FAIL	Pitot heat failure.	Double Chime
PITOT HEAT REQD	Pitot heat is required.	Double Chime ¹
START ENGAGED	Starter is engaged.	Double Chime
⁺ Optional / [*] Not applicable to all models /  TKS NH (optional) /  TKS FIKI (optional) / ¹ In air only		

ADVISORY ANNUNCIATIONS

Annunciation Window Text	Alerts Window Text	Audio Alert
ALTITUDE SEL⁺	Climbing away from selected altitude.	None
ALTITUDE SEL⁺	Descending away from selected altitude.	
AOA FAIL 	Dynamic stall speed band is not available.	
COURSE SEL⁺	Current track will not intercept selected course.	
HIGH MP FF[*]	Avoid fuel flow 18 to 30 GPH and MP above 26".	
L FUEL QTY	Check left fuel tank level.	Double Chime
OXYGEN LEFT ON⁺	Oxygen system is left on after shutdown.	
OXYGEN QTY⁺	Oxygen quantity is low.	
PUMP BACKUP 	Anti-ice backup pump mode has been selected (TKS).	
R FUEL QTY	Check right fuel tank level.	
⁺ Optional / [*] Not applicable to all models /  TKS FIKI (optional)		

COMPARATOR ANNUNCIATIONS

Comparator Window Text	Condition
ALT MISCOMP	Difference in altitude sensors is ≥ 200 ft.
IAS MISCOMP	If both airspeed sensors detect < 35 knots, this is inhibited.
	If either airspeed sensor detects ≥ 35 knots, and the difference in sensors is > 10 kts.
	If either airspeed sensor detects ≥ 80 knots, and the difference in sensors is > 7 kts.
HDG MISCOMP	Difference in heading sensors is > 6 degrees.
PIT MISCOMP	Difference in pitch sensors is > 5 degrees.
ROL MISCOMP	Difference in roll sensors is > 6 degrees.
ALT NO COMP	No data from one or both altitude sensors.
IAS NO COMP	No data from one or both airspeed sensors.
HDG NO COMP	No data from one or both heading sensors.
PIT NO COMP	No data from one or both pitch sensors.
ROL NO COMP	No data from one or both roll sensors..













REVERSIONARY SENSOR ANNUNCIATIONS (SR22 ONLY)

Reversionary Sensor Window Text	Condition
USING ADC2	The PFD is displaying data from the #2 Air Data Computer.
USING AHRS2	The PFD is displaying data from the #2 AHRS.

MESSAGE ADVISORY ALERTS

Alerts Window Message	Audio Alert
ANTI ICE QTY – Fluid quantity is low (TKS).	None
EXIT ICING – Exit icing conditions.	
MFD FAN FAIL – The cooling fan for the MFD is inoperative.	
PFD1 FAN FAIL – The cooling fan for PFD1 is inoperative.	

GFC 700 AFCS ALERTS

Condition	Annunciation	Description
Pitch Failure		Pitch axis control failure.
Roll Failure		Roll axis control failure.
Pitch Trim Axis Control Failure		If annunciated when AP is engaged, a failure has occurred in the pitch trim system.
Yaw Damper Failure		YD control failure (SR22 only).
System Failure		AP and MET are unavailable. FD may still be available.
Elevator Mistrim Up		A condition has developed causing the pitch servo to provide a sustained force in the nose up direction.
Elevator Mistrim Down		A condition has developed causing the pitch servo to provide a sustained force in the nose down direction.
Aileron Mistrim Left		A condition has developed causing the roll servo to provide a sustained left force.
Aileron Mistrim Right		A condition has developed causing the roll servo to provide a sustained right force.
Rudder Mistrim Left		A condition has developed causing the yaw servo to provide a sustained force (SR22 only).
Rudder Mistrim Right		A condition has developed causing the yaw servo to provide a sustained force (SR22 only).
Preflight Test		Performing preflight system test. Upon completion of the test, the aural alert will be heard.
		Preflight system test has failed.

TERRAIN-SVS ALERTS

Alert Type	PFD/MFD TERRAIN-SVS Page Annunciation	MFD Pop-Up Alert	Aural Message
Reduced Required Terrain Clearance Warning (RTC)	TERRAIN	WARNING - TERRAIN	"Warning; Terrain, Terrain"
Imminent Terrain Impact Warning (ITI)	TERRAIN	WARNING - TERRAIN	"Warning; Terrain, Terrain"
Reduced Required Obstacle Clearance Warning (ROC)	TERRAIN	WARNING - OBSTACLE	"Warning; Obstacle, Obstacle"
Imminent Obstacle Impact Warning (IOI)	TERRAIN	WARNING - OBSTACLE	"Warning; Obstacle, Obstacle"
Reduced Required Terrain Clearance Caution (RTC)	TERRAIN	CAUTION - TERRAIN	"Caution; Terrain, Terrain"
Imminent Terrain Impact Caution (ITI)	TERRAIN	CAUTION - TERRAIN	"Caution; Terrain, Terrain"
Reduced Required Obstacle Clearance Caution (ROC)	TERRAIN	CAUTION - OBSTACLE	"Caution; Obstacle, Obstacle"
Imminent Obstacle Impact Caution (IOI)	TERRAIN	CAUTION - OBSTACLE	"Caution; Obstacle, Obstacle"

Terrain-SVS System Status Annunciations

Alert Type	PFD/MFD Alert Annunciation	TERRAIN-SVS Page Annunciation	Aural Message
System Test in Progress	TER TEST	TERRAIN TEST	None
System Test Pass	None	None	"Terrain System Test OK"
Terrain Alerting is disabled	TER INH	None	None
MFD Terrain or Obstacle database unavailable or invalid. Terrain-SVS operating with PFD Terrain or Obstacle databases	None	TERRAIN DATABASE FAILURE	None

Alert Type	PFD/MFD Alert Annunciation	TERRAIN-SVS Page Annunciation	Aural Message
Terrain System Test Fail	TER FAIL	TERRAIN FAIL	"Terrain System Failure"
Terrain or Obstacle database unavailable or invalid, invalid software configuration, system audio fault	TER FAIL		"Terrain System Failure"
No GPS position	TER N/A	NO GPS POSITION	"Terrain System Not Available"
Excessively degraded GPS signal, Out of database coverage area	TER N/A	None	"Terrain System Not Available"
Sufficient GPS signal received after loss	None	None	"Terrain System Available"

TAWS-B ALERTS

Alert Type	PFD/MFD TAWS-B Page Annunciation	MFD Pop-Up Alert	Aural Message
Excessive Descent Rate Warning (EDR)	PULL UP	PULL-UP	"Pull Up"
Reduced Required Terrain Clearance Warning (RTC)	PULL UP	TERRAIN - PULL-UP or TERRAIN AHEAD - PULL-UP	"Terrain, Terrain; Pull Up, Pull Up" or "Terrain Ahead, Pull Up; Terrain Ahead, Pull Up"
Imminent Terrain Impact Warning (ITI)	PULL UP	TERRAIN AHEAD - PULL-UP or TERRAIN - PULL-UP	Terrain Ahead, Pull Up; Terrain Ahead, Pull Up" or "Terrain, Terrain; Pull Up, Pull Up"

- Flight Instruments
- EIS
- Nav/Com/XPDR/Audio
- AFCS
- GPS Nav
- Flight Planning
- Procedures
- Hazard Avoidance
- Additional Features
- Abnormal Operation
- Annun/Alerts
- Appendix
- Index

	Alert Type	PFD/MFD TAWS-B Page Annunciation	MFD Pop-Up Alert	Aural Message
Flight Instruments EIS Nav/Com/ XPDR/Audio	Reduced Required Obstacle Clearance Warning (ROC)	PULL UP	OBSTACLE - PULL-UP or OBSTACLE AHEAD - PULL-UP	"Obstacle, Obstacle; Pull Up, Pull Up" or "Obstacle Ahead, Pull Up; Obstacle Ahead, Pull Up"
AFCs	Imminent Obstacle Impact Warning (IOI)	PULL UP	OBSTACLE AHEAD - PULL-UP or OBSTACLE - PULL-UP	"Obstacle Ahead, Pull Up; Obstacle Ahead, Pull Up" or "Obstacle, Obstacle; Pull Up, Pull Up"
GPS Nav Flight Planning	Reduced Required Terrain Clearance Caution (RTC)	TERRAIN	CAUTION - TERRAIN or TERRAIN AHEAD	"Caution, Terrain; Caution, Terrain" or "Terrain Ahead; Terrain Ahead"
Procedures Hazard Avoidance	Imminent Terrain Impact Caution (ITI)	TERRAIN	TERRAIN AHEAD or CAUTION - TERRAIN	"Terrain Ahead; Terrain Ahead" or "Caution, Terrain; Caution, Terrain"
Additional Features	Reduced Required Obstacle Clearance Caution (ROC)	TERRAIN	CAUTION - OBSTACLE or OBSTACLE AHEAD	"Caution, Obstacle; Cau- tion, Obstacle" or "Obstacle Ahead; Obstacle Ahead"
Abnormal Operation Annun/ Alerts	Imminent Obstacle Impact Caution (IOI)	TERRAIN	OBSTACLE AHEAD or CAUTION - OBSTACLE	"Obstacle Ahead; Obstacle Ahead" or "Caution, Obstacle; Caution, Obstacle"
Appendix	Premature Descent Alert Caution (PDA)	TERRAIN	TOO LOW - TERRAIN	"Too Low, Terrain"
	Altitude Callout "500"	None	None	"Five-Hundred"
Index	Excessive Descent Rate Caution (EDR)	TERRAIN	SINK RATE	"Sink Rate"

Alert Type	PFD/MFD TAWS-B Page Annunciation	MFD Pop-Up Alert	Aural Message
Negative Climb Rate Caution (NCR)	TERRAIN	DON'T SINK or TOO LOW - TERRAIN	"Don't Sink" or "Too Low, Terrain"

TAWS-B System Status Annunciations

Alert Type	PFD/MFD Alert Annunciation	TAWS-B Page Annunciation	Aural Message
System Test in Progress	TAWS TEST	TAWS TEST	None
System Test Pass	None	None	"TAWS System Test OK"
TAWS Alerting is disabled	TAWS INH	None	None
MFD Terrain or Obstacle database unavailable or invalid. TAWS operating with PFD Terrain or Obstacle databases	None	TERRAIN DATABASE FAILURE	None
TAWS-B System Test Fail	TAWS FAIL	TAWS FAIL	"TAWS System Failure"
Terrain or Obstacle database unavailable or invalid, invalid software configuration, system audio fault	TAWS FAIL	TAWS FAIL	"TAWS System Failure"
No GPS position	TAWS N/A	NO GPS POSITION	"TAWS Not Available"
Excessively degraded GPS signal, Out of database coverage area	TAWS N/A	None	"TAWS Not Available"
Sufficient GPS signal received after loss	None	None	"TAWS Available"

AURAL ALERTS

Aural Alert	Description
"Airspeed"	Low airspeed when the autopilot is engaged (GFC 700 AFCS only).
"Minimums, minimums"	The aircraft has descended below the preset minimum descent altitude or decision altitude.
"Traffic, Traffic"	Played when a Traffic Advisory (TA) is issued (optional).
"Traffic Advisory System Test Passed"	Played when the Skywatch TAS system passes a pilot-initiated self test (optional).
"Traffic Advisory System Test Failed"	Played when the Skywatch TAS system fails a pilot-initiated self test (optional).
"Vertical track"	The aircraft is one minute from Top of Descent. Issued only when vertical navigation is enabled.
"One o'clock" through "Twelve o'clock" or "No Bearing"	Played to indicate bearing of traffic from own aircraft (GTS 800 only).
"High", "Low", "Same Altitude" (if within 200 feet of own altitude), or "Altitude not available"	Played to indicate altitude of traffic relative to own aircraft (GTS 800 only).
"Less than one mile", "One Mile" through "Ten Miles", or "More than ten miles"	Played to indicate distance of traffic from own aircraft (GTS 800 only).

CO GUARDIAN MESSAGES

Alerts Window Message	Comments
CO DET SRVC – The carbon monoxide detector needs service.	There is a problem within the CO Guardian that requires service.
CO DET FAIL – The carbon monoxide detector is inoperative.	Loss of communication between the Perspective™ system and the CO Guardian.

MFD & PFD MESSAGE ADVISORIES

Message	Comments
DATA LOST – Pilot stored data was lost. Recheck settings.	The pilot profile data was lost. System reverts to default pilot profile and settings. The pilot may reconfigure the MFD & PFD with preferred settings, if desired.
XTALK ERROR – A flight display crosstalk error has occurred.	The MFD and PFD are not communicating with each other. The Perspective™ system should be serviced.
PFD1 SERVICE – PFD1 needs service. Return unit for repair.	The PFD and/or MFD self-test has detected a problem. The Perspective™ system should be serviced.
MFD1 SERVICE – MFD1 needs service. Return unit for repair.	
MANIFEST – PFD1 software mismatch, communication halted.	The PFD and/or MFD has incorrect software installed. The Perspective™ system should be serviced.
MANIFEST – MFD1 software mismatch, communication halted.	
PFD1 CONFIG – PFD1 config error. Config service req'd.	The PFD configuration settings do not match backup configuration memory. The Perspective™ system should be serviced.
MFD1 CONFIG – MFD1 config error. Config service req'd.	The MFD configuration settings do not match backup configuration memory. The Perspective™ system should be serviced.
SW MISMATCH – GDU software version mismatch. Xtalk is off.	The MFD and PFD have different software versions installed. The Perspective™ system should be serviced.
PFD1 COOLING – PFD1 has poor cooling. Reducing power usage.	The PFD and/or MFD is overheating and is reducing power consumption by dimming the display. If problem persists, the Perspective™ system should be serviced.
MFD1 COOLING – MFD1 has poor cooling. Reducing power usage.	
PFD1 KEYSTK – PFD1 [key name] Key is stuck.	A key is stuck on the PFD and/or MFD bezel. Attempt to free the stuck key by pressing it several times. The Perspective™ system should be serviced if the problem persists.
MFD1 KEYSTK – MFD [key name] Key is stuck.	

MFD & PFD MESSAGE ADVISORIES (CONT.)

Message	Comments
CNFG MODULE – PFD1 configuration module is inoperative.	The PFD1 configuration module backup memory has failed. The Perspective™ system should be serviced.
PFD1 VOLTAGE – PFD1 has low voltage. Reducing power usage	The PFD1 voltage is low. The Perspective™ system should be serviced.
MFD1 VOLTAGE – MFD1 has low voltage. Reducing power usage	The MFD voltage is low. The Perspective™ system should be serviced.

DATABASE MESSAGE ADVISORIES

Message	Comments
MFD1 DB ERR – MFD1 navigation database error exists.	The MFD and/or PFD detected a failure in the navigation database. Attempt to reload the navigation database. If problem persists, the Perspective™ system should be serviced.
PFD1 DB ERR – PFD1 navigation database error exists.	
MFD1 DB ERR – MFD1 basemap database error exists.	The MFD and/or PFD detected a failure in the basemap database.
PFD1 DB ERR – PFD1 basemap database error exists.	
MFD1 DB ERR – MFD1 terrain database error exists.	The MFD and/or PFD detected a failure in the terrain database. Ensure that the terrain card is properly inserted in display. Replace terrain card. If problem persists, The Perspective™ system should be serviced.
PFD1 DB ERR – PFD1 terrain database error exists.	
MFD1 DB ERR – MFD1 terrain database missing.	
PFD1 DB ERR – PFD1 terrain database missing.	The terrain database is present on another LRU, but is missing on the specified LRU.
MFD1 DB ERR – MFD1 obstacle database error exists.	The MFD and/or PFD detected a failure in the obstacle database. Ensure that the data card is properly inserted. Replace data card. If problem persists, The Perspective™ system should be serviced.
PFD1 DB ERR – PFD1 obstacle database error exists.	

DATABASE MESSAGE ADVISORIES (CONT.)

Message	Comments
MFD1 DB ERR – MFD1 obstacle database missing.	The obstacle database is present on another LRU, but is missing on the specified LRU.
PFD1 DB ERR – PFD1 obstacle database missing.	
MFD1 DB ERR – MFD1 airport terrain database error exists.	The MFD and/or PFD detected a failure in the airport terrain database. Ensure that the data card is properly inserted. Replace data card. If problem persists, The Perspective™ system should be serviced.
PFD1 DB ERR – PFD1 airport terrain database error exists.	
MFD1 DB ERR – MFD1 airport terrain database missing.	The airport terrain database is present on another LRU, but is missing on the specified LRU.
PFD1 DB ERR – PFD1 airport terrain database missing.	
MFD1 DB ERR – MFD1 Safe Taxi database error exists.	The MFD and/or PFD detected a failure in the Safe Taxi database. Ensure that the data card is properly inserted. Replace data card. If problem persists, The Perspective™ system should be serviced.
PFD1 DB ERR – PFD1 Safe Taxi database error exists.	
MFD1 DB ERR – MFD1 Chartview database error exists.	The MFD and/or PFD detected a failure in the ChartView database (optional feature). Ensure that the data card is properly inserted. Replace data card. If problem persists, The Perspective™ system should be serviced.
MFD1 DB ERR – MFD1 FliteCharts database error exists.	The MFD and/or PFD detected a failure in the FliteCharts database (optional feature). Ensure that the data card is properly inserted. Replace data card. If problem persists, The Perspective™ system should be serviced.
MFD1 DB ERR – MFD1 Airport Directory database error exists.	The MFD detected a failure in the Airport Directory database. Ensure that the data card is properly inserted. Replace data card. If problem persists, the system should be serviced.

- Flight Instruments
- EIS
- Nav/Com/XPDR/Audio
- AFCS
- GPS Nav
- Flight Planning
- Procedures
- Hazard Avoidance
- Additional Features
- Abnormal Operation
- Annun/Alerts
- Appendix
- Index

DATABASE MESSAGE ADVISORIES (CONT.)

Message	Comments
DB MISMATCH – Navigation database mismatch. Xtalk is off.	The PFDs and MFD have different navigation database versions or types (Americas, European, etc.) installed. Crossfill is off. Install correct navigation database version or type in all displays.
DB MISMATCH – Standby Navigation database mismatch.	The PFDs and MFD have different standby navigation database versions or types (Americas, European, etc.) installed. Install correct standby navigation database version or type in all displays.
DB MISMATCH – Terrain database mismatch.	The PFDs and MFD have different terrain database versions or types installed. Install correct terrain database version or type in all displays.
DB MISMATCH – Obstacle database mismatch.	The PFDs and MFD have different obstacle database installed. Install correct obstacle database in all displays.
DB MISMATCH – Airport Terrain database mismatch.	The PFDs and MFD have different airport terrain databases installed. Install correct airport terrain database in all displays.
NAV DB UPDATED – Active navigation database updated.	System has updated the active navigation database from the standby navigation database.
TERRAIN DSP – [PFD1 or MFD1] Terrain awareness display unavailable.	One of the terrain, airport terrain, or obstacle databases required for TAWS in the PFD or MFD is missing or invalid.

GMA 347 MESSAGE ADVISORIES

Message	Comments
GMA1 FAIL – GMA1 is inoperative.	The audio panel self-test has detected a failure. The audio panel is unavailable. The Perspective™ system should be serviced.
GMA1 CONFIG – GMA1 config error. Config service req'd.	The audio panel configuration settings do not match backup configuration memory. The Perspective™ system should be serviced.

GMA 347 MESSAGE ADVISORIES (CONT.)

Message	Comments
MANIFEST – GMA1 software mismatch, communication halted.	The audio panel has incorrect software installed. The Perspective™ system should be serviced.
GMA1 SERVICE – GMA1 needs service. Return unit for repair.	The audio panel self-test has detected a problem. Certain audio functions may still be available, and the audio panel may still be usable. The Perspective™ system should be serviced when possible.

GIA 63W MESSAGE ADVISORIES

Message	Comments
GIA1 CONFIG – GIA1 config error. Config service req'd.	The GIA1 and/or GIA2 configuration settings do not match backup configuration memory. The Perspective™ system should be serviced.
GIA2 CONFIG – GIA2 config error. Config service req'd.	
GIA1 CONFIG – GIA1 audio config error. Config service req'd.	The GIA1 and/or GIA2 have an error in the audio configuration. The Perspective™ system should be serviced.
GIA2 CONFIG – GIA2 audio config error. Config service req'd.	
GIA1 COOLING – GIA1 temperature too low.	The GIA1 and/or GIA2 temperature is too low to operate correctly. Allow units to warm up to operating temperature.
GIA2 COOLING – GIA2 temperature too low.	
GIA1 COOLING – GIA1 over temperature.	The GIA1 and/or GIA2 temperature is too high. If problem persists, the Perspective™ system should be serviced.
GIA2 COOLING – GIA2 over temperature.	
GIA1 SERVICE – GIA1 needs service. Return the unit for repair.	The GIA1 and/or GIA2 self-test has detected a problem in the unit. The Perspective™ system should be serviced.
GIA2 SERVICE – GIA2 needs service. Return the unit for repair.	

GIA 63W MESSAGE ADVISORIES (CONT.)

Message	Comments
HW MISMATCH – GIA hardware mismatch. GIA1 communication halted.	A GIA mismatch has been detected, where only one is WAAS capable.
HW MISMATCH – GIA hardware mismatch. GIA2 communication halted.	
MANIFEST – GIA1 software mismatch, communication halted.	The GIA1 and/or GIA 2 has incorrect software installed. The Perspective™ system should be serviced.
MANIFEST – GIA2 software mismatch, communication halted.	
MANIFEST – GFC software mismatch, communication halted.	Incorrect servo software is installed, or gain settings are incorrect.
COM1 TEMP – COM1 over temp. Reducing transmitter power.	The system has detected an over temperature condition in COM1 and/or COM2. The transmitter is operating at reduced power. If the problem persists, the Perspective™ system should be serviced.
COM2 TEMP – COM2 over temp. Reducing transmitter power.	
COM1 SERVICE – COM1 needs service. Return unit for repair.	The system has detected a failure in COM1 and/or COM2. COM1 and/or COM2 may still be usable. The Perspective™ system should be serviced when possible.
COM2 SERVICE – COM2 needs service. Return unit for repair.	
COM1 PTT – COM1 push-to-talk key is stuck.	The COM1 and/or COM2 external push-to-talk switch is stuck in the enable (or “pressed”) position. Press the PTT switch again to cycle its operation. If the problem persists, the Perspective™ system should be serviced.
COM2 PTT – COM2 push-to-talk key is stuck.	
COM1 RMT XFR – COM1 remote transfer key is stuck.	The COM1 and/or COM2 transfer switch is stuck in the enabled (or “pressed”) position. Press the transfer switch again to cycle its operation. If the problem persists, the Perspective™ system should be serviced.
COM2 RMT XFR – COM2 remote transfer key is stuck.	

GIA 63W MESSAGE ADVISORIES (CONT.)

Message	Comments
LOI – GPS integrity lost. Crosscheck with other NAVS.	GPS integrity is insufficient for the current phase of flight.
GPS NAV LOST – Loss of GPS navigation. Insufficient satellites.	Loss of GPS navigation due to insufficient satellites.
GPS NAV LOST – Loss of GPS navigation. Position error.	Loss of GPS navigation due to position error.
GPS NAV LOST – Loss of GPS navigation. GPS fail.	Loss of GPS navigation due to GPS failure.
ABORT APR – Loss of GPS navigation. Abort approach.	Abort approach due to loss of GPS navigation.
APR DWNGRADE – Approach downgraded.	Vertical guidance generated by WAAS is unavailable, use LNAV only minimums.
TRUE APR – True north approach. Change HDG reference to TRUE.	Displayed after passing the first waypoint of a true north approach when the nav angle is set to 'AUTO'.
GPS1 SERVICE – GPS1 needs service. Return unit for repair.	A failure has been detected in the GPS1 and/or GPS2 receiver. The receiver may still be available. The Perspective™ system should be serviced.
GPS2 SERVICE – GPS2 needs service. Return unit for repair.	
NAV1 SERVICE – NAV1 needs service. Return unit for repair.	A failure has been detected in the NAV1 and/or NAV2 receiver. The receiver may still be available. The Perspective™ system should be serviced.
NAV2 SERVICE – NAV2 needs service. Return unit for repair.	
NAV1 RMT XFR – NAV1 remote transfer key is stuck.	The remote NAV1 and/or NAV2 transfer switch is stuck in the enabled (or "pressed") state. Press the transfer switch again to cycle its operation. If the problem persists, the Perspective™ system should be serviced.
NAV2 RMT XFR – NAV2 remote transfer key is stuck.	
G/S1 FAIL – G/S1 is inoperative.	A failure has been detected in glideslope receiver 1 and/or receiver 2. The Perspective™ system should be serviced.
G/S2 FAIL – G/S2 is inoperative.	

- Flight Instruments
- EIS
- Nav/Com/XPDR/Audio
- AFCS
- GPS Nav
- Flight Planning
- Procedures
- Hazard Avoidance
- Additional Features
- Abnormal Operation
- Annun/Alerts
- Appendix
- Index

GIA 63W MESSAGE ADVISORIES (CONT.)

Message	Comments
G/S1 SERVICE – G/S1 needs service. Return unit for repair.	A failure has been detected in glideslope receiver 1 and/or receiver 2. The receiver may still be available. The Perspective™ system should be serviced when possible.
G/S2 SERVICE – G/S2 needs service. Return unit for repair.	

GEA 71 MESSAGE ADVISORIES

Message	Comments
GEA1 CONFIG – GEA1 config error. Config service req'd.	The GEA1 configuration settings do not match those of backup configuration memory. The Perspective™ system should be serviced.
MANIFEST – GEA1 software mismatch, communication halted.	The #1 GEA 71 has incorrect software installed. The Perspective™ system should be serviced.

GTX 32 & GTX 33 MESSAGE ADVISORIES

Message	Comments
XPDR1 CONFIG – XPDR1 config error. Config service req'd.	The transponder configuration settings do not match those of backup configuration memory. The Perspective™ system should be serviced.
MANIFEST – GTX1 software mismatch, communication halted.	The transponder has incorrect software installed. The Perspective™ system should be serviced.
XPDR1 SRVC – XPDR1 needs service. Return unit for repair.	The #1 transponder should be serviced when possible.
XPDR1 FAIL – XPDR1 is inoperative.	There is no communication with the #1 transponder.

GRS 77 MESSAGE ADVISORIES

Message	Comments
AHRS1 TAS – AHRS1 not receiving valid airspeed.	The #1 AHRS is not receiving true airspeed from the air data computer. The AHRS relies on GPS information to augment the lack of airspeed. The Perspective™ system should be serviced.
AHRS2 TAS – AHRS2 not receiving valid airspeed.	The #2 AHRS is not receiving true airspeed from the air data computer. The AHRS relies on GPS information to augment the lack of airspeed. The Perspective™ system should be serviced.
AHRS1 GPS – AHRS1 using backup GPS source.	The #1 AHRS is using the backup GPS path. Primary GPS path has failed. The Perspective™ system should be serviced when possible.
AHRS2 GPS – AHRS2 using backup GPS source.	The #2 AHRS is using the backup GPS path. Primary GPS path has failed. The Perspective™ system should be serviced when possible.
AHRS1 GPS – AHRS1 not receiving any GPS information.	The #1 AHRS is not receiving any or any useful GPS information. Check AFMS limitations. The Perspective™ system should be serviced.
AHRS2 GPS – AHRS2 not receiving any GPS information.	The #2 AHRS is not receiving any or any useful GPS information. Check AFMS limitations. The Perspective™ system should be serviced.
AHRS1 GPS – AHRS1 not receiving backup GPS information.	The #1 AHRS is not receiving backup GPS information. The Perspective™ system should be serviced.
AHRS2 GPS – AHRS2 not receiving backup GPS information.	The #2 AHRS is not receiving backup GPS information. The Perspective™ system should be serviced.
AHRS1 GPS – AHRS1 operating exclusively in no-GPS mode.	The #1 AHRS is operating exclusively in no-GPS mode. The Perspective™ system should be serviced.
AHRS2 GPS – AHRS2 operating exclusively in no-GPS mode.	The #2 AHRS is operating exclusively in no-GPS mode. The Perspective™ system should be serviced.

GRS 77 MESSAGE ADVISORIES (CONT.)

Message	Comments
AHRS MAG DB – AHRS magnetic model database version mismatch.	The #1 AHRS and #2 AHRS magnetic model database versions do not match.
AHRS1 SRVC – AHRS1 Magnetic-field model needs update.	The #1 AHRS earth magnetic field model is out of date. Update magnetic field model when practical.
AHRS2 SRVC – AHRS2 Magnetic-field model needs update.	The #2 AHRS earth magnetic field model is out of date. Update magnetic field model when practical.
GEO LIMITS – AHRS1 too far North/South, no magnetic compass.	The aircraft is outside geographical limits for approved AHRS operation. Heading is flagged as invalid.
GEO LIMITS – AHRS2 too far North/South, no magnetic compass.	
MANIFEST – GRS1 software mismatch, communication halted.	The #1 AHRS has incorrect software installed. The Perspective™ system should be serviced.
MANIFEST – GRS2 software mismatch, communication halted.	The #2 AHRS has incorrect software installed. The Perspective™ system should be serviced.

GMU 44 MESSAGE ADVISORIES

Message	Comments
HDG FAULT – AHRS1 magnetometer fault has occurred.	A fault has occurred in the #1 GMU 44. Heading is flagged as invalid. The AHRS uses GPS for backup mode operation. The Perspective™ system should be serviced.
HDG FAULT – AHRS2 magnetometer fault has occurred.	A fault has occurred in the #2 GMU 44. Heading is flagged as invalid. The AHRS uses GPS for backup mode operation. The Perspective™ system should be serviced.
MANIFEST – GMU1 software mismatch, communication halted.	The GMU 44 has incorrect software installed. The Perspective™ system should be serviced.
MANIFEST – GMU2 software mismatch, communication halted.	

GDL 69/69A MESSAGE ADVISORIES

Message	Comments
GDL69 CONFIG – GDL 69 config error. Config service req'd.	GDL 69 configuration settings do not match those of backup configuration memory. The Perspective™ system should be serviced.
GDL69 FAIL – GDL 69 has failed.	A failure has been detected in the GDL 69. The receiver is unavailable. The Perspective™ system should be serviced
MANIFEST – GDL software mismatch, communication halted.	The GDL 69 has incorrect software installed. The Perspective™ system should be serviced.

GDC 74A MESSAGE ADVISORIES

Message	Comments
ADC1 ALT EC – ADC1 altitude error correction is unavailable.	GDC1 or GDC2 is reporting that the altitude error correction is unavailable.
ADC2 ALT EC – ADC2 altitude error correction is unavailable.	
ADC1 AS EC – ADC1 airspeed error correction is unavailable.	GDC1 or GDC2 is reporting that the airspeed error correction is unavailable.
ADC2 AS EC – ADC2 airspeed error correction is unavailable.	
MANIFEST – GDC1 software mismatch, communication halted.	The GDC 74A has incorrect software installed. The Perspective™ system should be serviced.
MANIFEST – GDC2 software mismatch, communication halted.	

GCU 478 MESSAGE ADVISORIES

Message	Comments
GCU CNFG – GCU Config error. Config service req'd.	GCU 478 configuration settings do not match those of backup configuration memory. The Perspective™ system should be serviced.
GCU FAIL – GCU is inoperative.	A failure has been detected in the GCU 478. The GCU 478 is unavailable.
MANIFEST – GCU software mismatch, communication halted.	The GCU 478 has incorrect software installed. The Perspective™ system should be serviced.
GCU KEYSTK – GCU [key name] Key is stuck.	A key is stuck on the GCU 478 bezel. Attempt to free the stuck key by pressing it several times. The Perspective™ system should be serviced if the problem persists.

GMC 705 MESSAGE ADVISORIES

Message	Comments
GMC CONFIG – GMC Config error. Config service req'd.	Error in the configuration of the GMC 705.
GMC FAIL – GMC is inoperative.	A failure has been detected in the GMC 705. The GMC 705 is unavailable.
MANIFEST – GMC software mismatch. Communication halted.	The GMC 705 has incorrect software installed. The Perspective™ system should be serviced.
GMC KEYSTK – GMC [key name] Key is stuck.	A key is stuck on the GMC 705 bezel. Attempt to free the stuck key by pressing it several times. The Perspective™ system should be serviced if the problem persists.

GTS 800 MESSAGE ADVISORIES

Message	Comments
GTS CONFIG – GTS config error. Config service req'd.	The GTS and GDU have incompatible configurations. This alert is also set when the GTS has an invalid mode S address configured or the mode S address does not match both XPDR mode S addresses.
MANIFEST – GTS software mismatch, communication halted.	The GTS has incorrect software installed. The Perspective™ system should be serviced.

MISCELLANEOUS MESSAGE ADVISORIES

Message	Comments
FPL WPT LOCK – Flight plan waypoint is locked.	Upon power-up, the Perspective™ system detects that a stored flight plan waypoint is locked. This occurs when an navigation database update eliminates an obsolete waypoint. The flight plan cannot find the specified waypoint and flags this message. This can also occur with user waypoints in a flight plan that is deleted. Remove the waypoint from the flight plan if it no longer exists in any database, Or update the waypoint name/identifier to reflect the new information.
FPL WPT MOVE – Flight plan waypoint moved.	The system has detected that a waypoint coordinate has changed due to a new navigation database update. Verify that stored flight plans contain correct waypoint locations.
TIMER EXPIRD – Timer has expired.	The system notifies the pilot that the timer has expired.

MISCELLANEOUS MESSAGE ADVISORIES (CONT.)

Message	Comments
DB CHANGE – Database changed. Verify user modified procedures.	This occurs when a stored flight plan contains procedures that have been manually edited. This alert is issued only after an navigation database update. Verify that the user-modified procedures in stored flight plans are correct and up to date.
DB CHANGE – Database changed. Verify stored airways.	This occurs when a stored flight plan contains an airway that is no longer consistent with the navigation database. This alert is issued only after an navigation database update. Verify use of airways in stored flight plans and reload airways as needed.
FPL TRUNC – Flight plan has been truncated.	This occurs when a newly installed navigation database eliminates an obsolete approach or arrival used by a stored flight plan. The obsolete procedure is removed from the flight plan. Update flight plan with current arrival or approach.
LOCKED FPL – Cannot navigate locked flight plan.	This occurs when the pilot attempts to activate a stored flight plan that contains locked waypoint. Remove locked waypoint from flight plan. Update flight plan with current waypoint.
WPT ARRIVAL – Arriving at waypoint -[xxxx]	Arriving at waypoint [xxxx], where [xxxx] is the waypoint name.
STEEP TURN – Steep turn ahead.	A steep turn is 15 seconds ahead. Prepare to turn.
INSIDE ARSPC – Inside airspace.	The aircraft is inside the airspace.
ARSPC AHEAD – Airspace ahead less than 10 minutes.	Special use airspace is ahead of aircraft. The aircraft will penetrate the airspace within 10 minutes.
ARSPC NEAR – Airspace near and ahead.	Special use airspace is near and ahead of the aircraft position.

MISCELLANEOUS MESSAGE ADVISORIES (CONT.)

Message	Comments
ARSPC NEAR – Airspace near – less than 2 nm.	Special use airspace is within 2 nm of the aircraft position.
APR INACTV – Approach is not active.	The system notifies the pilot that the loaded approach is not active. Activate approach when required.
SLCT FREQ – Select appropriate frequency for approach.	The system notifies the pilot to load the approach frequency for the appropriate NAV receiver. Select the correct frequency for the approach.
SLCT NAV – Select NAV on CDI for approach.	The system notifies the pilot to set the CDI to the correct NAV receiver. Set the CDI to the correct NAV receiver.
PTK FAIL – Parallel track unavailable: bad geometry.	Bad parallel track geometry.
PTK FAIL – Parallel track unavailable: invalid leg type.	Invalid leg type for parallel offset.
PTK FAIL – Parallel track unavailable: past IAF.	IAF waypoint for parallel offset has been passed.
UNABLE V WPT – Can't reach current vertical waypoint.	The current vertical waypoint can not be reached within the maximum flight path angle and vertical speed constraints. The system automatically transitions to the next vertical waypoint.
VNV – Unavailable. Unsupported leg type in flight plan.	The lateral flight plan contains a procedure turn, vector, or other unsupported leg type prior to the active vertical waypoint. This prevents vertical guidance to the active vertical waypoint.
VNV – Unavailable. Excessive track angle error.	The current track angle error exceeds the limit, causing the vertical deviation to go invalid.
VNV – Unavailable. Excessive crosstrack error.	The current crosstrack exceeds the limit, causing vertical deviation to go invalid.

Flight Instruments

EIS

Nav/Com/XPDR/Audio

AFCS

GPS Nav

Flight Planning

Procedures

Hazard Avoidance

Additional Features

Abnormal Operation

Annun/Alerts

Appendix

Index

MISCELLANEOUS MESSAGE ADVISORIES (CONT.)

Message	Comments
VNV – Unavailable. Parallel course selected.	A parallel course has been selected, causing the vertical deviation to go invalid.
NO WGS84 WPT – Non WGS 84 waypoint for navigation -[xxxx]	The position of the selected waypoint [xxxx] is not calculated based on the WGS84 map reference datum and may be positioned in error as displayed. Do not use GPS to navigate to the selected non-WGS84 waypoint.
TRAFFIC FAIL – Traffic device has failed.	The Perspective™ is no longer receiving data from the traffic system. The traffic device should be serviced.
STRMSCP FAIL – Stormscope has failed.	Stormscope has failed. The Perspective™ system should be serviced.
FAILED PATH – A data path has failed.	A data path connected to the GDU or the GIA 63/W has failed.
FAILED PATH – An autopilot servo data path has failed.	A data path connected to an autopilot servo has failed. Only available if GFC 700 is installed.
MAG VAR WARN – Large magnetic variance. Verify all course angles.	The GDU's internal model cannot determine the exact magnetic variance for geographic locations near the magnetic poles. Displayed magnetic course angles may differ from the actual magnetic heading by more than 2°.
SVS – SVS DISABLED: Out of available terrain region.	Synthetic Vision is disabled because the aircraft is not within the boundaries of the installed terrain database.
SVS – SVS DISABLED: Terrain DB resolution too low.	Synthetic Vision is disabled because a terrain database of sufficient resolution (9 arc-second or better) is not currently installed.
SCHEDULER [#] – <message>.	Message criteria entered by the user.
CHECK CRS – Database course for LOC1 / [LOC ID] is [CRS]°.	Selected course for LOC1 differs from published localizer course by more than 10 degrees.

MISCELLANEOUS MESSAGE ADVISORIES (CONT.)

Message	Comments
CHECK CRS – Database course for LOC2 / [LOC ID] is [CRS]°.	Selected course for LOC2 differs from published localizer course by more than 10 degrees.
[PFD1 or MFD1] CARD 1 REM – Card 1 was removed. Reinsert card.	The SD card was removed from the top card slot of the PFD or MFD. The SD card needs to be reinserted.
[PFD1 or MFD1] CARD 2 REM – Card 2 was removed. Reinsert card.	The SD card was removed from the bottom card slot of the PFD or MFD. The SD card needs to be reinserted.
[PFD1 or MFD1] CARD 1 ERR – Card 1 is invalid.	The SD card in the top card slot of the PFD or MFD contains invalid data.
[PFD1 or MFD1] CARD 2 ERR – Card 2 is invalid.	The SD card in the bottom card slot of the PFD or MFD contains invalid data.

FLIGHT PLAN IMPORT/EXPORT MESSAGES

In some circumstances, some messages may appear in conjunction with others.

Flight Plan Import/Export Results	Description
'Flight plan successfully imported.'	A flight plan file stored on the SD card was successfully imported as a stored flight plan.
'File contained user waypoints only. User waypoints imported successfully. No stored flight plan data was modified.'	The file stored on the SD card did not contain a flight plan, only user waypoints. These waypoints have been saved to the system user waypoints. No flight plans stored in the system have been modified.
'No flight plan files found to import.'	The SD card contains no flight plan data.
'Flight plan import failed.'	Flight plan data was not successfully imported from the SD card.
'Flight plan partially imported.'	Some flight plan waypoints were successfully imported from the SD card, however others had errors and were not imported. A partial stored flight plan now exists in the system.

- Flight Instruments
- EIS
- Nav/Com/XPDR/Audio
- AFCS
- GPS Nav
- Flight Planning
- Procedures
- Hazard Avoidance
- Additional Features
- Abnormal Operation
- Annun/Alerts
- Appendix
- Index

Flight Plan Import/Export Results	Description
'File contained user waypoints only.'	The file stored on the SD card did not contain a flight plan, only user waypoints. One or more of these waypoints did not import successfully.
'Too many points. Flight plan truncated.'	The flight plan on the SD card contains more waypoints than the system can support. The flight plan was imported with as many waypoints as possible.
'Some waypoints not loaded. Waypoints locked.'	The flight plan on the SD card contains one or more waypoints that the system cannot find in the navigation database. The flight plan has been imported, but must be edited within the system before it can be activated for use.
'User waypoint database full. Not all loaded.'	The flight plan file on the SD card contains user waypoints. The quantity of stored user waypoints has exceeded system capacity, therefore not all the user waypoints on the SD card have been imported. Any flight plan user waypoints that were not imported are locked in the flight plan. The flight plan must be edited within the system before it can be activated for use.
'One or more user waypoints renamed.'	One or more imported user waypoints were renamed when imported due to naming conflicts with waypoints already existing in the system.
'Flight plan successfully exported.'	The stored flight plan was successfully exported to the SD card.
'Flight plan export failed.'	The stored flight plan was not successfully exported to the SD card. The SD card may not have sufficient available memory or the card may have been removed prematurely.

APPENDIX

PFD SOFTKEY MAP

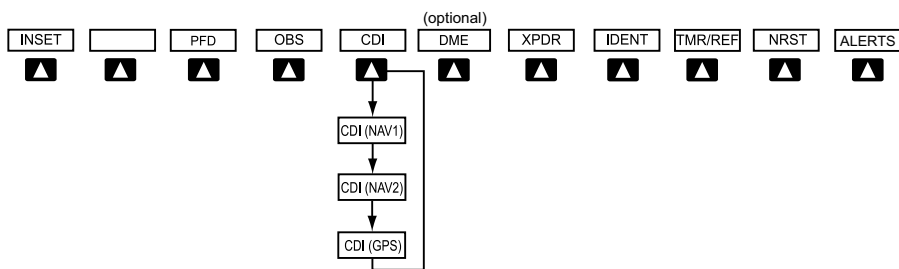

Top Level PFD Softkeys

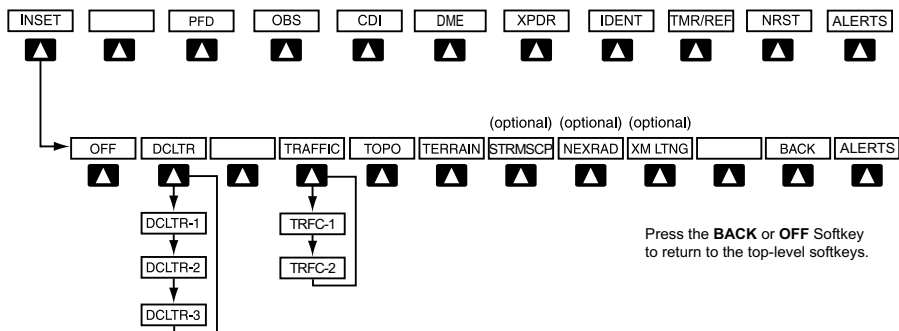

Inset Map Softkeys

INSET		Displays Inset Map in PFD lower left corner
	OFF	Removes Inset Map
	DCLTR (3)	Selects desired amount of map detail; cycles through declutter levels: DCLTR (No Declutter): All map features visible DCLTR-1: Declutters land data DCLTR-2: Declutters land and SUA data DCLTR-3: Removes everything except the active flight plan

Flight Instruments	TRAFFIC	Cycles through traffic display options: TRFC-1: Traffic displayed on inset map TRFC-2: Traffic Map Page is displayed in the inset map window
EIS	TOPO	Displays topographical data (e.g., coastlines, terrain, rivers, lakes) and elevation scale on Inset Map
Nav/Com/XPDR/Audio	TERRAIN	Displays terrain information on Inset Map
AFCs	STRMSCP	Press to display the Stormscope lightning data on the Inset Map (within a 200 nm radius of the aircraft)
GPS Nav	NEXRAD	Displays NEXRAD weather and coverage information on Inset Map (optional feature)
Flight Planning	XM LTNG	Displays XM lightning information on Inset Map (optional feature)

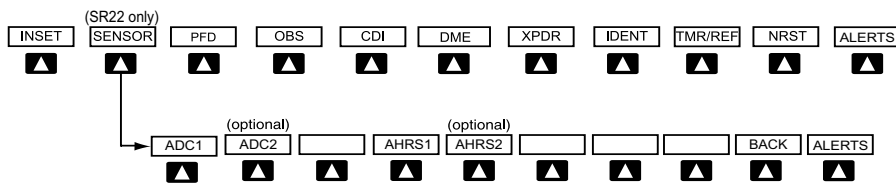

Press the **BACK** Softkey to return to the top level softkeys.

Sensor Softkeys

SENSOR	Displays softkeys for selecting the #1 and #2 AHRS and Air Data Computers (SR22 only)
ADC1	Selects the #1 Air Data Computer
ADC2	Selects the #2 Air Data Computer
AHRS1	Selects the #1 AHRS
AHRS2	Selects the #2 AHRS

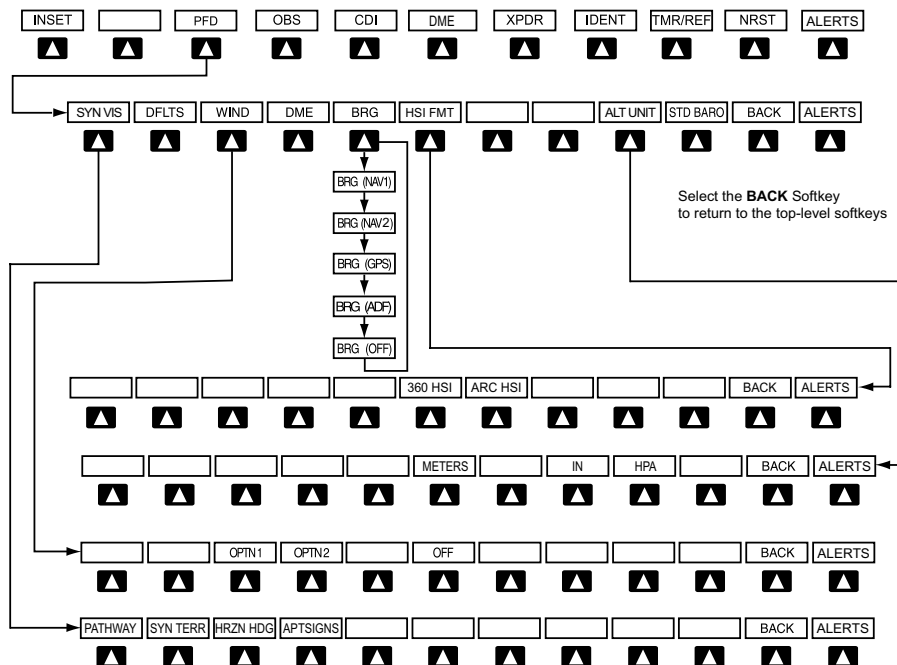

PFD Configuration Softkeys

PFD			Displays second-level softkeys for additional PFD configurations
	SYN VIS		Displays the softkeys for enabling or disabling Synthetic Vision features
		PATHWAY	Displays rectangular boxes representing the horizontal and vertical flight path of the active flight plan
		SYN TERR	Enables synthetic terrain depiction
		HRZN HDG	Displays compass heading along the Zero-Pitch line
		APTSIGNS	Displays position markers for airports within approximately 15 nm of the current aircraft position. Airport identifiers are displayed when the airport is within approximately 9 nm.

Flight Instruments	DFLTS		Resets PFD to default settings, including changing units to standard
EIS	WIND		Displays softkeys to select wind data parameters
Nav/Com/XPDR/Audio		OPTN 1	Wind direction arrow with direction and speed
AFCs		OPTN 2	Wind direction arrows with headwind and crosswind components
GPS Nav		OFF	Information not displayed
Flight Planning	DME		Select to display the DME information window
Procedures	BRG		Cycles the Bearing Information Window through NAV1, NAV2 or GPS/waypoint identifier and GPS-derived distance information, and ADF.
Hazard Avoidance	HSI FRMT		Displays the HSI formatting softkeys
Additional Features		360 HSI	Displays the HSI in a 360 degree format
Abnormal Operation		ARC HSI	Displays the HSI in an arc format
Annun/Alerts	ALT UNIT		Displays softkeys for setting the altimeter and BARO settings to metric units
Appendix		METERS	When enabled, displays altimeter in meters
Index		IN	Select to display the BARO setting as inches of mercury
		HPA	Select to display the BARO setting as hectopascals
	STD BARO		Sets altimeter setting to standard barometric pressure

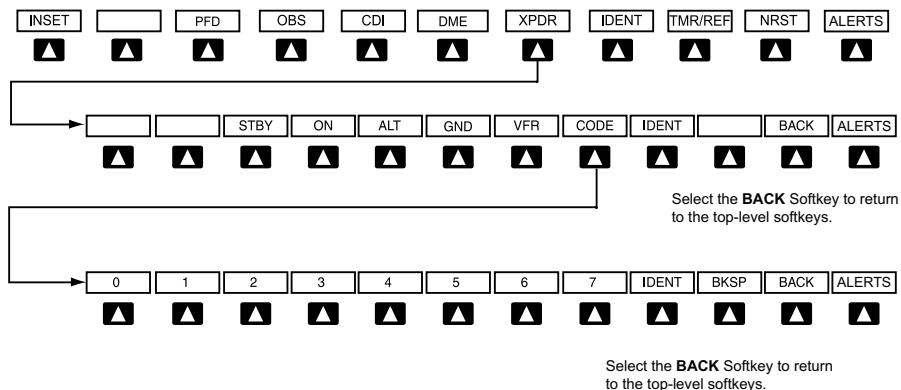

Transponder Softkeys

XPDR		Displays transponder mode selection softkeys
	STBY	Selects Standby Mode (transponder does not reply to any interrogations)
	ON	Selects Mode A (transponder replies to interrogations)
	ALT	Selects Mode C – Altitude Reporting Mode (transponder replies to identification and altitude interrogations)
	GND	Manually selects Ground Mode, the transponder does not allow Mode A and Mode C replies, but it does permit acquisition squitter and replies to discretely addressed Mode S interrogations.
	VFR	Automatically enters the VFR code (1200 in the U.S.A. only)

Flight Instruments	CODE		Displays transponder code selection softkeys 0-7
		0 — 7	Use numbers to enter code
EIS		BKSP	Removes numbers entered, one at a time
Nav/Com/XPDR/Audio	IDENT		Activates the Special Position Identification (SPI) pulse for 18 seconds, identifying the transponder return on the ATC screen
AFCs	TMR/REF		Displays Timer/References Window
	NRST		Displays Nearest Airports Window
	ALERTS		Displays the Alerts Window

MFD SOFTKEY MAP

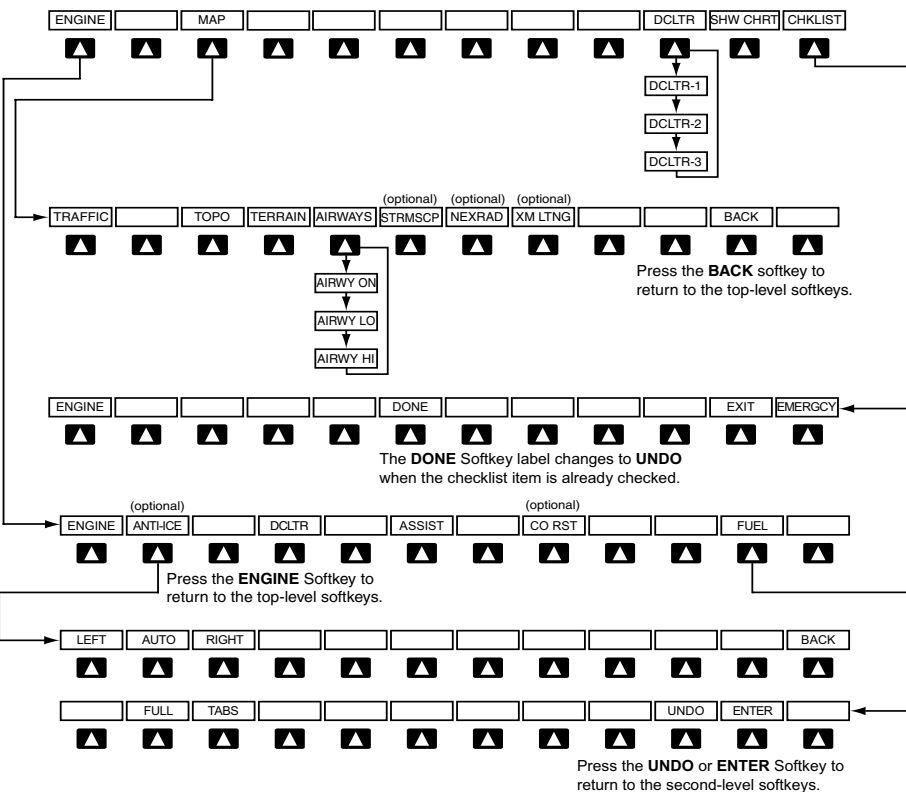

MFD Softkeys

ENGINE			Displays full Engine Page and second-level engine softkeys; press again to return to the Engine Strip and top-level softkeys
	ANTI-ICE		Displays Anti-ice softkeys (optional-FIKI only)
		LEFT	Selects manual mode and opens the left tank valve and closes the right tank valve
		AUTO	Selects Auto Tank Mode
		RIGHT	Selects manual mode and opens the right tank valve and closes the left tank valve
	DCLTR		Declutters the Engine Temperatures Box removing bars and temperatures readouts
	ASSIST		Identifies temperature peaks
	CO RST		Resets the CO Guardian (optional)
	FUEL		Accesses the Initial Usable Fuel Page
		FULL	Resets fuel totalizer to full (<i>usable fuel</i>)
		TABS	Resets fuel totalizer to tabs (<i>usable fuel</i>)
		UNDO	Rejects the last entry and resets to the previous entry
		ENTER	Saves the usable fuel amount shown on the Initial Usable Fuel Page
MAP			Enables second-level Navigation Map softkeys
	TRAFFIC		Displays traffic information on Navigation Map
	TOPO		Displays topographical data (e.g., coastlines, terrain, rivers, lakes) and elevation scale on Navigation Map
	TERRAIN		Displays terrain information on Navigation Map

Flight Instruments		AIRWAYS	Displays airways on the map; cycles through the following: AIRWAYS: No airways are displayed AIRWY ON: All airways are displayed AIRWY LO: Only low altitude airways are displayed AIRWY HI: Only high altitude airways are displayed
EIS			
Nav/Com/XPDR/Audio			
AFCs			
GPS Nav		STRMSCP	Displays Stormscope lightning on the Navigation Map (optional feature). Stormscope lightning and XM lightning are mutually exclusive when displaying on the Navigation Map.
Flight Planning		NEXRAD	Displays NEXRAD weather and coverage information on Navigation Map (optional feature)
Procedures		XM LTNG	Displays XM lightning information on Navigation Map (optional feature)
Hazard Avoidance		BACK	Returns to top-level softkeys
Additional Features		DCLTR (3)	Selects desired amount of map detail; cycles through declutter levels: DCLTR (No Declutter): All map features visible DCLTR-1: Declutters land data DCLTR-2: Declutters land and SUA data DCLTR-3: Removes everything except the active flight plan
Abnormal Operation		SHW CHRT	When available, displays optional airport and terminal procedure charts
Annun/Alerts		CHKLIST	When available, displays optional checklists

LOADING UPDATED DATABASES

In some cases it may be necessary to obtain an unlock code from Garmin in order to make the database product functional. It may also be necessary to have the system configured by a Garmin authorized service facility in order to use some database features.

If an error occurs during synchronization, an error message will be displayed, followed by the affected display in the Sync Status section of the Database Window. If synchronization completes on one display, but an error occurs on another, the error message will be displayed with the affected displays listed after it. When an error message is displayed, the problem must be corrected before synchronization can be completed. A power cycle is required to restart synchronization when 'Card Full' or 'Err' is shown.

Error Message	Description
Canceled	An active synchronization has been canceled using the SYNC DBS Softkey
Card Full	SD card does not contain sufficient memory
Err	Displayed for all other errors that may cause the synchronization process to be halted
Timeout	System timed-out prior to the database transfer completing

Loading Garmin Database Updates

- 1) With system power OFF, remove the MFD database card from the bottom card slot of the MFD.
- 2) Update the Garmin databases on the MFD card.
- 3) Insert the MFD database card into the bottom card slot of the MFD.
- 4) Apply power to the system, check that the databases are initialized and displayed on the power-up screen. When updating the terrain and FliteCharts databases, a 'Verifying' message may be seen. If this message is present, wait for the system to finish loading before proceeding to step 5.
- 5) Acknowledge the Power-up Page agreement by pressing the **ENT** Key or the right most softkey.
- 6) Turn the large **FMS** Knob to select the AUX Page group on the MFD.
- 7) Turn the small **FMS** Knob to select the System Status Page.

- 8) Make sure the **SYNC DBS** Softkey is in the enabled state.
- 9) Monitor the Sync Status in the Database Window. Wait for all databases to complete synching, indicated by 'Complete' being displayed.
- 10) Remove and reapply power to the system.
- 11) Turn the large **FMS** Knob to select the AUX Page group on the MFD.
- 12) Turn the small **FMS** Knob to select the System Status Page.
- 13) Press the Display Database Selection Softkey to show database information for each display (**MFD1 DB**, **PFD1 DB**). Verify the correct database cycle information is shown for each database for each display.

Loading the Jeppesen Navigation Database as the Active Navigation Database



NOTE: Loading the Jeppesen navigation database as the active database prior to its effective date will result in the expiration date on the power-up screen and the effective date on the AUX-System Status Page being displayed in yellow.

- 1) With the system OFF, insert the SD card containing the new navigation database version into the top card slot of the display (PFD or MFD) to be updated (label of SD card facing left).
- 2) Turn the system ON. A prompt similar to the following is displayed in the upper left corner of the display:
- 3) Press the **NO** Softkey to proceed to loading the active database.
- 4) A prompt similar to the following is displayed. Press the **YES** Softkey to update the active navigation database.
- 5) After the update completes, the display starts in normal mode.
- 6) Turn the system OFF and remove the SD card from the top card slot.
- 7) Repeat steps 1 through 6 for the other display (PFD or MFD).
- 8) Apply power to the system and press the **ENT** Key to acknowledge the startup screen.
- 9) Turn the large **FMS** Knob to select the AUX Page group on the MFD.
- 10) Turn the small **FMS** Knob to select the System Status Page.
- 11) Press the Display Database Selection Softkey to show active navigation database information for each display (**MFD1 DB**, **PFD1 DB**). Verify the correct active navigation database cycle information is shown for each display.



NOTE: After the navigation database is loaded or copied, the top SD card may be removed.

Loading the Jeppesen Navigation Database as the Standby Navigation Database

- 1) With the system OFF, insert the SD card containing the new navigation database version into the top card slot of the MFD.
- 2) Verify that an SD card is inserted in the bottom slot of the PFD and MFD.
- 3) Turn the system ON. A prompt screen is displayed.
- 4) Press the **YES** Softkey. The navigation database is copied to the SD card in the bottom card slot of the MFD.
- 5) Press the **NO** Softkey. The display now starts in normal mode. Since the database effective date is not yet valid, it should not be loaded as the active database.
- 6) Press the **ENT** Key to acknowledge the startup screen.



NOTE: During the synchronization process, version differences between standby navigation databases will exist. This will result in the system displaying a 'DB Mismatch' alert for the standby navigation databases. This alert will remain until the next power cycle.

- 7) Turn the large **FMS** Knob to select the AUX Page group on the MFD.
- 8) Turn the small **FMS** Knob to select the System Status Page.
- 9) If necessary, press the **SYNC DBS** Softkey to enable database synchronization. A confirmation box is displayed. If Database Synchronization has been enabled prior to this step, proceed to step 11.
- 10) With YES highlighted, press the **ENT** Key.
- 11) The new database is copied to the SD card in bottom card slot of the PFD. Progress can be monitored in the SYNC STATUS field. When copying is finished, 'Complete' is displayed.
- 12) Turn system power OFF.
- 13) Remove the SD card from the top card slot of the MFD.
- 14) Turn system power ON.

- 15) Press the **ENT** Key to acknowledge the startup screen.
- 16) Turn the large **FMS** Knob to select the AUX Page group on the MFD.
- 17) Turn the small **FMS** Knob to select the System Status Page.
- 18) Press the Display Database Selection Softkey to show standby navigation database information for each display (**MFD1 DB, PFD1 DB**). Verify the correct standby navigation database cycle information is shown for each display.



NOTE: After the navigation database is loaded or copied, the top SD card may be removed.

Canceling Database Synchronization

- 1) Turn the large **FMS** Knob to select the AUX Page group on the MFD.
- 2) Turn the small **FMS** Knob to select the System Status Page.
- 3) Press the **SYNC DBS** Softkey (if needed) to disable automatic database synchronization.
- 4) Acknowledge the cancellation by pressing the **ENT** Key.

The **SYNC DBS** Softkey on the AUX–System Status Page allows enabling and disabling the automatic database synchronization feature. If the **SYNC DBS** Softkey is pressed while a database synchronization is in progress, the current synchronization process will be canceled.

A

- Activate a flight plan 22
- Active Channel 60
- Active database 106
- ADF 13, 14
- Advisory alerts 72
- AHRS 87, 88, 90
- Airport Signs 55, 56
- Airways 104
- Altimeter setting 1, 66
- Anti-ice 10
- AOPA's Airport Directory 59
- AP 73
- Assist, engine leaning 9–11
- Audio panel controls
 - NAV1, NAV2 14

B

- Barometric Altitude Minimums 2

C

- Caution alerts 70
- CDI 1, 14, 93
- Cell 45, 46
- Cell mode 46
- Channel Presets 61
- ChartView 57, 58
- Checklists 62–63
- Clearance player 15
- Clearance Recorder 15
- Code selection softkeys 13
- COM 13, 14, 15, 65

D

- Database synchronization 108
- DCLTR Softkey 57
- Dead Reckoning 67
- Declutter 66, 97, 104

- Designated altitudes 25
- Direct-to 21
- DME 13, 14
- DR mode 67, 68

E

- Edit a flight plan 37
- Electronic checklists 62, 63
- Emergency checklist 63
- Enable Terrain 52
- Enhanced Vision System RR-1, 56
- EVS 56, 57
- Exhaust Gas Temperature (EGT) 9–10

F

- FD 73
- Flight Director 17
- Flight ID 49
- Flight path marker 55
- Flight plan import/export messages 95
- FliteCharts® 57, 58
- Frequency Transfer 14
- Fuel 6, 7, 9, 11, 103
- Fuel calculations 7, 11
- Fuel flow 5, 7
- Fuel totalizer 7, 103

H

- Horizon heading 55

I

- Inhibit 51, 54
- Inhibit TAWS 54
- Inhibit Terrain 51, 52
- Inset Map 97, 98
- Intercom isolation 14
- IOI 74, 76

Flight
Instruments

EIS

Nav/Com/
XPDR/Audio

AFCS

GPS Nav

Flight
Planning

Procedures

Hazard
Avoidance

Additional
Features

Abnormal
Operation

Annun/
Alerts

Appendix

Index

- J**
Jeppesen 58
- L**
Lightning 45, 46, 98
- M**
Map panning 47
Message advisories 79–88, 90–95
MET 73
METAR 47
Minimums 78
MISCOMP 72
Mistrim 73
MKR/MUTE 15
Mode S 101
Mode selection softkeys 13
Multi Function Display (MFD)
Softkeys 102
- N**
NAV 14
NAV1 1, 14
NAV2 1, 14
Navigation database 23, 25, 82
NEXRAD 47, 48, 98, 104
- O**
OBS 1
Obstacles 82, 84
- P**
Pathways 55, 56
PIT 72
Power-up page 62
- R**
Reversionary mode 65
ROC 74, 76
- S**
SafeTaxi® 57
Secure Digital (SD) card 62
Sensor 72
Store Flight Plan 37
Stormscope lightning data 45, 46, 98
Strike 45
Strike mode 46
SVS 55, 94
SVS Terrain 55
Synchronization 105, 108
Synthetic Vision System 55
- T**
TA 78
TAF 47
TAS 87
TAWS 52, 53, 54, 75
Terrain 50, 51, 52, 82, 98, 103
Terrain-SVS 20, 51, 52, 74
Timer 2, 91
TKS FIKI 11
Topographical data 98, 103
Traffic 45, 103
Traffic Advisory 78
Traffic map page 48, 49, 50
Transponder 13, 101, 102
- V**
Vertical speed guidance 25
Vertical track 78
VNV 21, 66, 93, 94
Voice alerts 69
Vspeed 2

W

WAAS 84

Warning alerts 69

Waypoint Selection Submenu 33, 34

Weather data link page 47

Wind data 100

X

XM lightning 98, 104

XM weather 47

- Flight Instruments
- EIS
- Nav/Com/XPDR/Audio
- AFCs
- GPS Nav
- Flight Planning
- Procedures
- Hazard Avoidance
- Additional Features
- Abnormal Operation
- Annun/Alerts
- Appendix
- Index

Blank Page



GARMIN



Garmin International, Inc.
1200 East 151st Street
Olathe, KS 66062, U.S.A.
p: 913.397.8200 f: 913.397.8282

Garmin AT, Inc.
2345 Turner Road SE
Salem, OR 97302, U.S.A.
p: 503.391.3411 f: 503.364.2138

Garmin (Europe) Ltd
Liberty House, Bulls Copse Road
Hounsdown Business Park
Southampton, SO40 9RB, U.K.
p: 44/0870.8501241 f: 44/0870.8501251

Garmin Corporation
No. 68, Jangshu 2nd Road
Shijr, Taipei County, Taiwan
p: 886/2.2642.9199 f: 886/2.2642.9099

www.garmin.com