

**PILOT'S OPERATING HANDBOOK
AND FAA APPROVED
AIRPLANE FLIGHT MANUAL
for the
CIRRUS DESIGN SR22**

**Aircraft Serials 0002 thru 2978, 2980 thru 2991, 2993
thru 3001, 3003 thru 3025, 3027 and subs with
Analog or Avidyne Avionics System**



FAA Approved in Normal Category based on FAR 23. This document must be carried in the airplane at all times and be kept within the reach of the pilot during all flight operations.

THIS HANDBOOK INCLUDES THE MATERIAL REQUIRED TO BE FURNISHED TO THE PILOT BY FAR PART 23 AND ADDITIONAL INFORMATION PROVIDED BY CIRRUS DESIGN AND CONSTITUTES THE FAA APPROVED AIRPLANE FLIGHT MANUAL.

Model - Serial Num. SR22-_____ Registration Num. _____

FAA Approved Joseph C. Mess Date Oct 10 2003
Royace H. Prather, Manager
Chicago Aircraft Certification Office, ACE-115C
Federal Aviation Administration

P/N 13772-001
Reissue A: 10-10-03



CIRRUS
AIRCRAFT

Copyright © 2003 - All Rights Reserved
Cirrus Design Corporation
4515 Taylor Circle
Duluth, MN 55811

List of Effective Pages

Use this page to determine the current effective date for each page in the POH. Supplements are issued individually and are controlled by the Log of Supplements Page in Section 9.

Dates of original issue and revised pages are:

Reissue.....A.....	10 Oct 2003	Revision.....A6.....	18 Jan 2006
Revision.....A1.....	06 Feb 2004	Revision.....A7.....	09 Aug 2006
Revision.....A2.....	03 Jul 2004	Revision.....A8.....	15 Dec 2007
Revision.....A3.....	30 Jan 2005	Revision.....A9.....	26 Aug 2009
Revision.....A4.....	18 Jul 2005	Revision.....A10.....	09 May 2011
Revision.....A5.....	12 Oct 2005		

Page	Status	Page	Status	Page	Status
Foreword-i	Reissue A	2-19	Revision A8	3-27	Revision A7
Foreword-ii	Revision A7	2-20	Revision A10	3-28	Revision A7
Foreword-iii	Revision A1	2-21	Revision A8	3A-1	Revision A5
Foreword-iv	Reissue A	2-22	Revision A5	3A-2	Revision A5
Foreword-v	Reissue A	2-23	Revision A5	3A-3	Revision A5
Foreword-vi	Reissue A	2-24	Revision A5	3A-4	Revision A5
1-1	Revision A3	2-25	Revision A5	3A-5	Revision A9
1-2	Revision A3	2-26	Revision A9	3A-6	Revision A10
1-3	Reissue A	2-27	Revision A5	3A-7	Revision A5
1-4	Revision A3	2-28	Revision A5	3A-8	Revision A5
1-5	Reissue A	3-1	Revision A7	3A-9	Revision A8
1-6	Revision A9	3-2	Revision A7	3A-10	Revision A5
1-7	Revision A8	3-3	Revision A5	3A-11	Revision A5
1-8	Revision A5	3-4	Revision A5	3A-12	Revision A5
1-9	Revision A7	3-5	Revision A5	3A-13	Revision A5
1-10	Revision A7	3-6	Revision A7	3A-14	Revision A7
1-11	Revision A7	3-7	Revision A5	4-1	Revision A7
1-12	Revision A7	3-8	Revision A5	4-2	Revision A7
2-1	Revision A7	3-9	Revision A5	4-3	Revision A5
2-2	Revision A7	3-10	Revision A5	4-4	Revision A5
2-3	Revision A5	3-11	Revision A10	4-5	Revision A5
2-4	Revision A5	3-12	Revision A5	4-6	Revision A8
2-5	Revision A5	3-13	Revision A7	4-7	Revision A8
2-6	Revision A9	3-14	Revision A10	4-8	Revision A8
2-7	Revision A9	3-15	Revision A5	4-9	Revision A8
2-8	Revision A5	3-16	Revision A10	4-10	Revision A8
2-9	Revision A9	3-17	Revision A9	4-11	Revision A5
2-10	Revision A5	3-18	Revision A8	4-12	Revision A5
2-11	Revision A8	3-19	Revision A7	4-13	Revision A6
2-12	Revision A8	3-20	Revision A7	4-14	Revision A10
2-13	Revision A8	3-21	Revision A7	4-15	Revision A10
2-14	Revision A8	3-22	Revision A7	4-16	Revision A5
2-15	Revision A8	3-23	Revision A7	4-17	Revision A8
2-16	Revision A8	3-24	Revision A7	4-18	Revision A9
2-17	Revision A8	3-25	Revision A7	4-19	Revision A5
2-18	Revision A5	3-26	Revision A7	4-20	Revision A5

FAA Approved Joseph C Miss Date May 9, 2011
 for Charles Smalley, Manager
 Chicago Aircraft Certification Office, ACE-115C
 Federal Aviation Administration

List of Effective Pages (Cont.)

Page	Status	Page	Status	Page	Status
4-21	Revision A8	6-18	Revision A10	7-55	Revision A5
4-22	Revision A8	7-1	Revision A10	7-56	Revision A8
4-23	Revision A5	7-2	Revision A10	7-57	Revision A5
4-24	Revision A5	7-3	Revision A10	7-58	Revision A5
4-25	Revision A5	7-4	Revision A10	7-59	Revision A5
4-26	Revision A5	7-5	Revision A5	7-60	Revision A5
4-27	Revision A10	7-6	Revision A5	7-61	Revision A5
4-28	Revision A8	7-7	Revision A5	7-62	Revision A6
4-29	Revision A5	7-8	Revision A5	7-63	Revision A5
4-30	Revision A5	7-9	Revision A5	7-64	Revision A5
5-1	Revision A10	7-10	Revision A5	7-65	Revision A5
5-2	Revision A10	7-11	Revision A5	7-66	Revision A5
5-3	Revision A10	7-12	Revision A5	7-67	Revision A8
5-4	Revision A10	7-13	Revision A5	7-68	Revision A7
5-5	Revision A10	7-14	Revision A7	7-69	Revision A7
5-6	Revision A10	7-15	Revision A5	7-70	Revision A7
5-7	Revision A10	7-16	Revision A5	7-71	Revision A7
5-8	Revision A10	7-17	Revision A5	7-72	Revision A9
5-9	Revision A10	7-18	Revision A5	7-73	Revision A7
5-10	Revision A10	7-19	Revision A5	7-74	Revision A10
5-11	Revision A10	7-20	Revision A5	7-75	Revision A10
5-12	Revision A10	7-21	Revision A5	7-76	Revision A10
5-13	Revision A10	7-22	Revision A5	7-77	Revision A10
5-14	Revision A10	7-23	Revision A5	7-78	Revision A10
5-15	Revision A10	7-24	Revision A6	7-79	Revision A10
5-16	Revision A10	7-25	Revision A8	7-80	Revision A10
5-17	Revision A10	7-26	Revision A5	7-81	Revision A10
5-18	Revision A10	7-27	Revision A5	7-82	Revision A10
5-19	Revision A10	7-28	Revision A5	7-83	Revision A10
5-20	Revision A10	7-29	Revision A5	7-84	Revision A10
5-21	Revision A10	7-30	Revision A5	7-85	Revision A10
5-22	Revision A10	7-31	Revision A5	7-86	Revision A10
5-23	Revision A10	7-32	Revision A5	7-87	Revision A10
5-24	Revision A10	7-33	Revision A5	7-88	Revision A10
5-25	Revision A10	7-34	Revision A5	7-89	Revision A10
5-26	Revision A10	7-35	Revision A5	7-90	Revision A10
5-27	Revision A10	7-36	Revision A5	7-91	Revision A10
5-28	Revision A10	7-37	Revision A5	7-92	Revision A10
6-1	Revision A10	7-38	Revision A5	7-93	Revision A10
6-2	Revision A10	7-39	Revision A7	7-94	Revision A10
6-3	Reissue A	7-40	Revision A7	7-95	Revision A10
6-4	Reissue A	7-41	Revision A5	7-96	Revision A10
6-5	Revision A2	7-42	Revision A5	7-97	Revision A10
6-6	Revision A2	7-43	Revision A5	7-98	Revision A10
6-7	Revision A3	7-44	Revision A5	7-99	Revision A10
6-8	Revision A10	7-45	Revision A8	7-100	Revision A10
6-9	Revision A8	7-46	Revision A5	7-101	Revision A10
6-10	Reissue A	7-47	Revision A5	7-102	Revision A10
6-11	Reissue A	7-48	Revision A5	7-103	Revision A10
6-12	Revision A10	7-49	Revision A7	7-104	Revision A10
6-13	Revision A10	7-50	Revision A5	7-105	Revision A10
6-14	Revision A10	7-51	Revision A5	7-106	Revision A10
6-15	Revision A10	7-52	Revision A5	7-107	Revision A10
6-16	Revision A10	7-53	Revision A5	7-108	Revision A10
6-17	Revision A10	7-54	Revision A7	7-109	Revision A10

List of Effective Pages (Cont.)

Page	Status	Page	Status	Page	Status
7-110	Revision A10				
7-111	Revision A10				
7-112	Revision A10				
8-1	Revision A9				
8-2	Revision A9				
8-3	Reissue A				
8-4	Reissue A				
8-5	Reissue A				
8-6	Revision A7				
8-7	Revision A7				
8-8	Revision A5				
8-9	Revision A5				
8-10	Reissue A				
8-11	Reissue A				
8-12	Revision A3				
8-13	Reissue A				
8-14	Reissue A				
8-15	Revision A3				
8-16	Revision A10				
8-17	Revision A10				
8-18	Revision A10				
8-19	Revision A9				
8-20	Revision A9				
8-21	Revision A9				
8-22	Revision A9				
8-23	Revision A9				
8-24	Revision A9				
8-25	Revision A9				
8-26	Revision A9				
8-27	Revision A9				
8-28	Revision A9				
8-29	Revision A9				
8-30	Revision A9				
8-31	Revision A9				
8-32	Revision A9				
8-33	Revision A9				
8-34	Revision A9				
9-1	Reissue A				
9-2	Reissue A				
9-3	Revision A10				
9-4	Revision A10				
10-1	Revision A6				
10-2	Revision A1				
10-3	Revision A1				
10-4	Revision A7				
10-5	Revision A1				
10-6	Revision A1				
10-7	Revision A4				
10-8	Revision A1				
10-9	Revision A8				
10-10	Revision A6				
10-11	Revision A9				
10-12	Revision A6				

SR22 Airplane Flight Manual (AFM)

Temporary Change

Affected Publication: SR22 POH Part Number:
• 13772-001 Revision A10
• 13772-001E Revision A10
• 13772-001AR Revision A10
• 21400-001 Revision 6

Filing Instructions: Insert this temporary change in Section 5 -
Performance adjacent to the Range / Endurance
tables on page 5-23 and retain until further notice.

Purpose: This POH Temporary Revision corrects the Range/
Endurance table data.

Section 5 - Performance

Range / Endurance Profile

- See following page -

FAA Approved Joseph C. Miss Date Jun 30, 2011
for Charles Smalley, Manager
Chicago Aircraft Certification Office, ACE-115C
Federal Aviation Administration

SR22 Airplane Flight Manual (AFM)

Temporary Change

Information in this Temporary Change adds to, supersedes, or deletes information in the basic Pilot's Operating Handbook.

Affected Publications: SR22 Basic Airplane Flight Manuals:

- PN 13772-001 Rev A10 (FAA Approved)
- PN 13772-001E Rev A10 (FAA Approved on Behalf of the European Aviation Safety Agency (EASA))
- PN 13772-001AR Rev A10 (FAA Approved on Behalf of DNA Argentina)
- PN 21400-001 Rev 6 Original (FAA Approved on Behalf of ANAC Brazil)

Filing Instructions: Insert the following revised pages and retain until further notice. Remove and discard the superseded pages. Insert this TPOH cover page adjacent to the last page of the List of Effective Pages and retain until further notice.

Purpose: This POH Temporary Change adds descriptions associated with the CAPS system. TPOH was revised October 29, 2013 to add effectivity to Section 7.

Affected Sections:

- Section 7 - Airplane and Systems Description

FAA Approved

Ronald A. McElroy

Oct 29, 2013
Date

for Charles Smalley, Manager
Chicago Aircraft Certification Office, ACE-115C
Federal Aviation Administration

Intentionally Left Blank

SR22 Airplane Flight Manual (AFM)

Temporary Change

Information in this Temporary Change adds to, supersedes, or deletes information in the basic Pilot's Operating Handbook.

Affected Publications:	SR22 Basic Airplane Flight Manuals: <ul style="list-style-type: none">• PN 13772-004 Rev 1 / 13772-002 Reissue A / 13772-001 Rev A10 (FAA Approved)• PN 13772-004AR Rev 1 / 13772-002AR Reissue A / 13772-001AR Rev A10 (FAA Approved on behalf of ANAC-DA of Argentina)• PN 13772-004E Rev 1 / 13772-002E Rev 2 / 13772-001E Rev A10 (FAA Approved on behalf of EASA)• PN 21400-004 Rev 1 / 21400-002 Rev 2 / 21400-001 Rev 6 (FAA Approved on behalf of ANAC of Brazil)
Filing Instructions:	Insert the following changes adjacent to the first page of each affected POH Section, and insert this TPOH cover page adjacent to the last page of the List of Effective Pages. Retain until further notice.
Purpose:	This POH Temporary Change updates information associated with the Brake System. TPOH was revised 01 Nov 2019 to revise Affected Publications and update nose and main tire PSI.

Affected Sections:

- Section 7 - Systems Description
- Section 8 - Handling and Servicing
- Section 10 - Safety Information

FAA Approved William P. Tower ^{Nov 01, 2019}
Date
Manager, Southwest Flight Test Section, AIR-713
Federal Aviation Administration
Ft. Worth, TX

Intentionally Left Blank

SR22 Airplane Flight Manual (AFM) Temporary Change

Information in this Temporary Change adds to, supersedes, or deletes information in the basic Pilot's Operating Handbook.

Affected Publications: SR22 Basic Airplane Flight Manuals:

- PN 13772-001 Rev A10 (FAA Approved)
- PN 13772-001E Rev A10 (FAA Approved on Behalf of the European Aviation Safety Agency (EASA))
- PN 13772-001AR Rev A10 (FAA Approved on Behalf of ANAC-DA of Argentina)
- PN 21400-001 Rev 6 (FAA Approved on Behalf of ANAC of Brazil)

Filing Instructions: Insert the following changes adjacent to the first page of each affected POH Section, and insert this TPOH cover page adjacent to the last page of the List of Effective Pages. Retain until further notice.

Purpose: This POH Temporary Change adds descriptions associated with the fire extinguisher.

Affected Sections:

- Sections 7 - Systems Description

FAA Approved

Ronald A. McElroy

Apr 28, 2015
Date

for Timothy Smyth, Manager
Chicago Aircraft Certification Office, ACE-115C
Federal Aviation Administration

Intentionally Left Blank

SR22 Airplane Flight Manual (AFM)

Temporary Change

Information in this Temporary Change adds to, supersedes, or deletes information in the basic Pilot's Operating Handbook.

- Affected Publications: SR22 Basic Airplane Flight Manuals:
- PN 13772-002 Reissue A (FAA Approved)
 - PN 13772-002E Rev 2 (FAA Approved on Behalf of the European Aviation Safety Agency (EASA))
 - PN 13772-002AR Reissue A (FAA Approved on Behalf of ANAC-DA of Argentina)
 - PN 21400-002 Rev 2 (FAA Approved on Behalf of ANAC of Brazil)
 - PN 13772-001 Rev A10 (FAA Approved)
 - PN 13772-001E Rev A10 (FAA Approved on Behalf of the European Aviation Safety Agency (EASA))
 - PN 13772-001AR Rev A10 (FAA Approved on Behalf of ANAC-DA of Argentina)
 - PN 21400-001 Rev 6 (FAA Approved on Behalf of ANAC of Brazil)
- Filing Instructions: Insert the following changes adjacent to the first page of each affected POH Section, and insert this TPOH cover page adjacent to the last page of the List of Effective Pages. Retain until further notice.
- Purpose: This POH Temporary Change updates the Cruise procedure.

Affected Sections:

- Section 4 - Normal Procedures

FAA Approved Ronald A. McElroy Jun 26, 2015
Date
for Timothy Smyth, Manager
Chicago Aircraft Certification Office, ACE-115C
Federal Aviation Administration

Intentionally Left Blank

SR22 Airplane Flight Manual (AFM)

Temporary Change

Information in this Temporary Change adds to, supersedes, or deletes information in the basic Pilot's Operating Handbook.

- Affected Publications: SR22 Basic Airplane Flight Manual:
- PN 13772-001 Rev A10
(FAA Approved)
 - PN 13772-001AR Rev A10
(FAA Approved on behalf of ANAC-DA of Argentina)
 - PN 13772-001E Rev A10
(FAA Approved on behalf of EASA)
 - PN 21400-001 Rev 6
(FAA Approved on behalf of ANAC of Brazil)

Filing Instructions: Insert the following revised pages and retain until further notice. Remove and discard the superseded pages. Insert this TPOH cover page adjacent to the last page of the List of Effective Pages and retain until further notice.

Purpose: This POH Temporary Change revises the Fuel Annunciation description.

Affected Sections:

- Section 7 - Airplane and Systems Description
- Pages 7-57 through 7-60

FAA Approved



May 11, 2018
Date

Manager, Southwest Flight Test Section, AIR-713
Federal Aviation Administration
Ft. Worth, TX

Intentionally Left Blank

Foreword

This Pilot's Operating Handbook (POH or Handbook) has been prepared by Cirrus Design Corporation to familiarize operators with the Cirrus Design SR22 airplane. Read this Handbook carefully. It provides operational procedures that will assure the operator obtains the performance published in the manual, data designed to allow the most efficient use of the airplane, and basic information for maintaining the airplane in a "like new" condition.

• Note •

All limitations, procedures, maintenance & servicing requirements, and performance data contained in this Handbook are mandatory for compliance with FAA operating rules and for continued airworthiness of the airplane.

This Handbook includes the material required to be furnished to the pilot by the Federal Aviation Regulations (FARs) and additional information provided by Cirrus Design Corporation and constitutes the FAA Approved Airplane Flight Manual for the Cirrus Design SR22.

The Handbook

This Pilot's Operating Handbook has been prepared using GAMA Specification #1 for Pilot's Operating Handbook, Revision 2, dated 18 October 1996 as the content model and format guide. However, some deviations from this specification were made for clarity. The Handbook is presented in loose-leaf form for ease in inserting revisions and is sized for convenient storage. Tabbed dividers throughout the Handbook allow quick reference to each section. Logical and convenient Tables of Contents are located at the beginning of each section to aid in locating specific data within that section. The Handbook is divided into ten sections as follows:

Section 1.....	General
Section 2.....	Limitations
Section 3.....	Emergency Procedures
Section 3A.....	Abnormal Procedures
Section 4.....	Normal Procedures
Section 5.....	Performance Data
Section 6.....	Weight & Balance/Equipment List
Section 7.....	Airplane & Systems Description
Section 8.....	Handling, Servicing & Maintenance
Section 9.....	Supplements
Section 10.....	Safety Information

The data presented in this Handbook is the result of extensive flight tests and is approved by the Federal Aviation Administration. However, as new procedures or performance data are developed, they will be sent to the owner of record for each airplane.

• Note •

It is the responsibility of the owner to ensure that the Pilot's Operating Handbook is current at all times. Therefore, it is very important that all revisions be properly incorporated into this Handbook as soon as they are received.

Revising the Handbook

Two types of revisions may be issued for this Handbook: Numbered and Temporary.

Temporary revisions are printed on yellow paper, normally cover only one topic or procedure, and are issued to provide safety related information or other time sensitive information where the rigor of providing a numbered revision is not possible in the time allowed. All the information needed to properly file a temporary revision is included on the revision itself. Typically, a temporary revision is superseded and replaced by the next numbered revision. A "Log of Temporary Revisions" following the "List of Effective Pages" is provided to log temporary revisions when they are issued. Typically, the "Log of Temporary Revisions" is replaced at the next numbered revision.

Numbered revisions are printed on white paper, normally cover several subjects, and are issued as general updates to the Handbook. Each numbered revision includes an "Instruction Sheet," a "List of Effective Pages", and a "Revision Highlights" page. The "Instruction Sheet" is intended to assist the manual holder in removing superseded pages and inserting new or superseding pages. The "List of Effective Pages" shows the issue or revision status of all pages in the Handbook. The "Revision Highlights" page gives a brief description of changes made to each page in the current revision.

Identifying Revised Material

Each page in the Handbook has revision identification at the lower inside corner opposite the page number. Original issue pages will be identified by the words "Original Issue" at this location. In the event that the majority of pages in the Handbook are revised, Cirrus may determine that it is more effective to reissue the Handbook. Reissued pages will be identified by the word "Reissue" followed by a letter indicating the reissue level; for example, "Reissue A" Revised pages will be identified by the word "Revision" followed by the revision number at this location; for example, "Revision 2" (Original Issue, Revision 2) or "Revision B1" (Reissue B, Revision 1).

Revised material on a page can be identified by a change bar located at the outside page margin. See the outside margin of this page adjacent to this paragraph for an example. Revision bars are not used at reissues of the Handbook.

Revision Service

Revision service for this Handbook is provided at no cost for the Pilot's Operating Handbook and FAA Approved Airplane Flight Manual assigned to an airplane. Additional copies of the Handbook and revision service can be obtained from Customer Service at Cirrus Design at the address below.

• Note •

If at any time it is found that the Handbook is not current, temporary revisions are missing, or applicable supplements are not included, contact Customer Service at Cirrus Design immediately.

Customer Service
Cirrus Design Corporation
4515 Taylor Circle
Duluth, MN 55811
Phone: (218) 727-2737
Fax: (218) 727-2148

Supplements

The Supplements section (Section 9) of this Handbook contains FAA Approved Supplements necessary to safely and efficiently operate the SR22 when equipped with optional equipment not provided with the standard airplane or not included in the Handbook. Supplements are essentially "mini-handbooks" and may contain data corresponding to most sections of the Handbook. Data in a supplement either adds to, supersedes, or replaces similar data in the basic Handbook.

Section 9 includes a "Log of Supplements" page preceding all Cirrus Design Supplements produced for this airplane. The "Log of Supplements" page can be utilized as a "Table of Contents" for Section 9. If the airplane is modified at a non Cirrus Design facility through an STC or other approval method, it is the owner's responsibility to ensure that the proper supplement, if applicable, is installed in the Handbook and that the supplement is properly recorded on the "Log of Supplements" page.

Retention of Data

In the event a new title page is issued, the weight and balance data changes, equipment list changes, or the "Log of Supplements" is replaced, the owner must ensure that all information applicable to the airplane is transferred to the new pages and the aircraft records are current. It is not a requirement that owners retain information, such as supplements, that is not applicable to their airplane.

Warnings, Cautions, and Notes

Warnings, Cautions, and Notes are used throughout this Handbook to focus attention on special conditions or procedures as follows:

• **WARNING** •

Warnings are used to call attention to operating procedures which, if not strictly observed, may result in personal injury or loss of life.

• **Caution** •

Cautions are used to call attention to operating procedures which, if not strictly observed, may result in damage to equipment.

• **Note** •

Notes are used to highlight specific operating conditions or steps of a procedure.

Intentionally Left Blank

Section 1

General

Table of Contents

Introduction	1-3
The Airplane.....	1-6
Engine.....	1-6
Propeller	1-6
Fuel.....	1-6
Oil	1-7
Maximum Certificated Weights	1-7
Cabin and Entry Dimensions	1-7
Baggage Spaces and Entry Dimensions	1-7
Specific Loadings.....	1-7
Symbols, Abbreviations and Terminology.....	1-8
General Airspeed Terminology and Symbols	1-8
Meteorological Terminology.....	1-9
Engine Power Terminology.....	1-10
Performance and Flight Planning Terminology.....	1-10
Weight and Balance Terminology.....	1-11

Intentionally Left Blank

Introduction

This section contains information of general interest to pilots and owners. You will find the information useful in acquainting yourself with the airplane, as well as in loading, fueling, sheltering, and handling the airplane during ground operations. Additionally, this section contains definitions or explanations of symbols, abbreviations, and terminology used throughout this handbook.

• Note •

For specific information regarding the organization of this Handbook, revisions, supplements, and procedures to be used to obtain revision service for this handbook, *refer to the "Foreword" immediately following the title page*

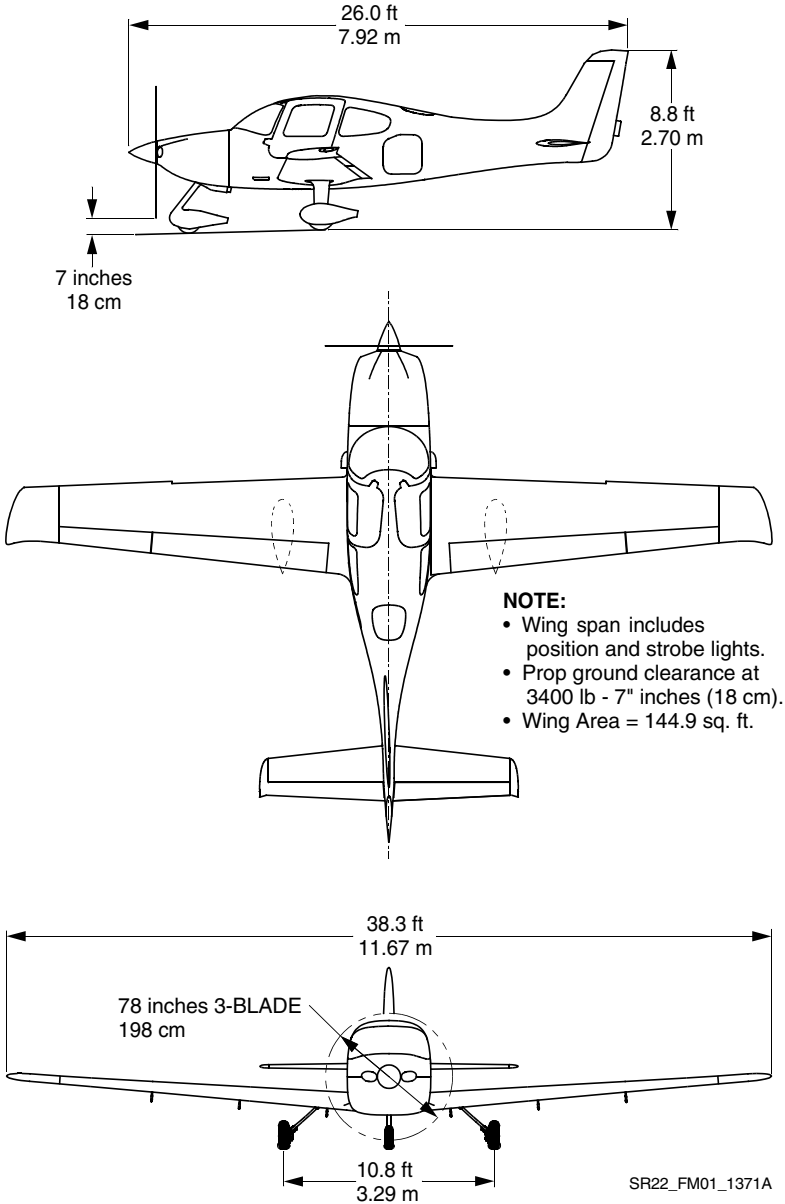
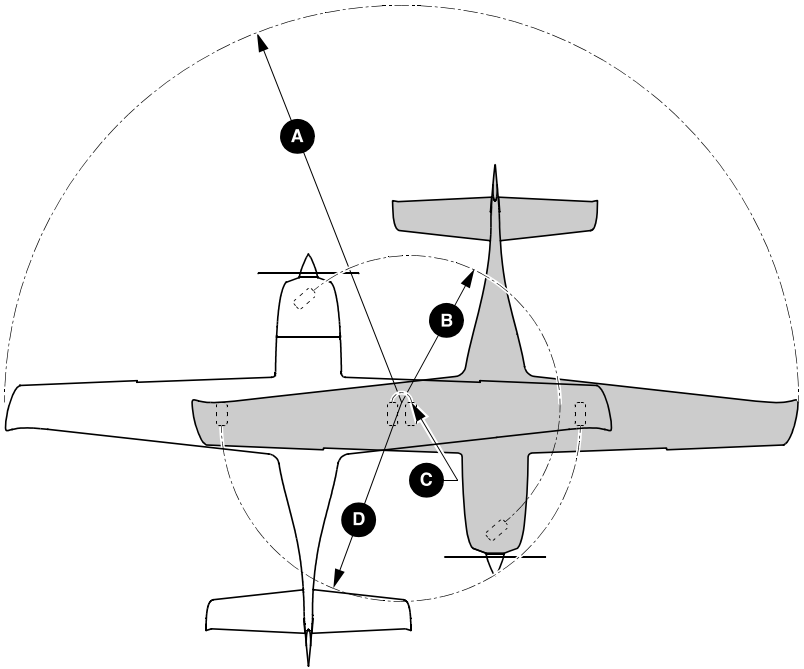

Figure 1-1
Airplane Three View



GROUND TURNING CLEARANCE

- A** -RADIUS FOR WING TIP 24.8 ft. (7.54 m)
- B** -RADIUS FOR NOSE GEAR 7.0 ft. (2.16 m)
- C** -RADIUS FOR INSIDE GEAR 0.5 ft. (.15 m)
- D** -RADIUS FOR OUTSIDE GEAR 10.8 ft. (3.30 m)

TURNING RADII ARE CALCULATED USING ONE BRAKE AND PARTIAL POWER. ACTUAL TURNING RADIUS MAY VARY AS MUCH AS THREE FEET.

SR22_FM01_1370

Figure 1-2
Turning Radius

The Airplane

Engine

Number of Engines..... 1
Number of Cylinders.....6
Engine Manufacturer Teledyne Continental
Engine Model..... IO-550-N
Fuel Metering..... Fuel Injected
Engine Cooling Air Cooled
Engine Type.....Horizontally Opposed, Direct Drive
Horsepower Rating.....310 hp @ 2700 rpm

Propeller

Hartzell

Propeller Type..... Constant Speed, Three Blade
Model NumberPHC-J3YF-1RF/F7694(B)
Diameter78.0" (76.0" Minimum)
Model Number PHC-J3YF-1RF/F7693DF(B)
Diameter 78.0" (76.0" Minimum)

or

McCaughey

Propeller Type..... Constant Speed, Three Blade
Model Number D3A34C443/78CYA-0
Diameter 78.0" (76.0" Minimum)

or

MT Propeller

Propeller Type..... Constant Speed, Three Blade
Model Number MTV-9-D/198-52
Diameter 78.0" (76.0" Minimum)

Fuel

Total Capacity.....84.0 U.S. Gallons (318.0 L)

Total Usable.....81.0 U.S. Gallons (306.6 L)

Approved Fuel Grades:

100 LL Grade Aviation Fuel (Blue)

100 (Formerly 100/130) Grade Aviation Fuel (Green)

Oil

Oil Capacity (Sump) 8 U.S. Quarts (7.6 L)

Oil Grades:

All Temperatures SAE 15W-50, 20W-50, or 20W-60

Below 40 °F (4° C) SAE 30

Above 40 °F (4° C) SAE 50

Maximum Certificated Weights

Maximum Gross for Takeoff..... 3400 lb (1542 Kg)

Maximum Baggage Compartment Loading..... 130 lb (59 Kg)

Standard Empty Weight 2250 lb (1021 Kg)

Maximum Useful Load..... 1150 lb (522 Kg)

Full Fuel Payload..... 676 lb (307 Kg)

Cabin and Entry Dimensions

Dimensions of the cabin interior and entry door openings are illustrated in detail in Section 6.

Baggage Spaces and Entry Dimensions

Dimensions of the baggage area and baggage door opening are illustrated in detail in Section 6.

Specific Loadings

Wing Loading 23.5 lb per square foot

Power Loading..... 11.0 lb per hp

Symbols, Abbreviations and Terminology

General Airspeed Terminology and Symbols

KCAS **Knots Calibrated Airspeed** is the indicated airspeed corrected for position and instrument error. Calibrated airspeed is equal to true airspeed in standard atmosphere at sea level.

IAS **Knots Indicated Airspeed** is the speed shown on the airspeed indicator. The IAS values published in this handbook assume no instrument error.

KTAS **Knots True Airspeed** is the airspeed expressed in knots relative to undisturbed air which is KCAS corrected for altitude and temperature.

V_G **Best Glide Speed** is the speed at which the greatest flight distance is attained per unit of altitude lost with power off.

V_O **Operating Maneuvering Speed** is the maximum speed at which application of full control movement will not overstress the airplane.

V_{FE} **Maximum Flap Extended Speed** is the highest speed permissible with wing flaps in a prescribed extended position.

V_{NO} **Maximum Structural Cruising Speed** is the speed that should not be exceeded except in smooth air, and then only with caution.

V_{NE} **Never Exceed Speed** is the speed that may not be exceeded at any time.

V_{PD} **Maximum Demonstrated Parachute Deployment Speed** is the maximum speed at which parachute deployment has been demonstrated.

V_S **Stalling Speed** is minimum steady flight speed at which the aircraft is controllable.

$V_{S 50\%}$ **Stalling Speed** is minimum steady flight speed at which the aircraft is controllable with 50% flaps.

- V_{SO} **Stalling Speed** is the minimum steady flight speed at which the aircraft is controllable in the landing configuration (100% flaps) at the most unfavorable weight and balance.
- V_X **Best Angle of Climb Speed** is the speed at which the airplane will obtain the highest altitude in a given horizontal distance. The best angle-of-climb speed normally increases slightly with altitude.
- V_Y **Best Rate of Climb Speed** is the speed at which the airplane will obtain the maximum increase in altitude per unit of time. The best rate-of-climb speed decreases slightly with altitude.

Meteorological Terminology

- IMC** **Instrument Meteorological Conditions** are meteorological conditions expressed in terms of visibility, distance from cloud, and ceiling less than the minima for visual flight defined in FAR 91.155.
- ISA** **International Standard Atmosphere** (standard day) is an atmosphere where (1) the air is a dry perfect gas, (2) the temperature at sea level is 15° C, (3) the pressure at sea level is 29.92 in.Hg (1013.2 millibars), and (4) the temperature gradient from sea level to the altitude at which the temperature is -56.5° C is -0.00198° C per foot and zero above that altitude.
- MSL** **Mean Sea Level** is the average height of the surface of the sea for all stages of tide. In this Handbook, altitude given as MSL is the altitude above the mean sea level. It is the altitude read from the altimeter when the altimeter's barometric adjustment has been set to the altimeter setting obtained from ground meteorological sources.
- OAT** **Outside Air Temperature** is the free air static temperature obtained from inflight temperature indications or from ground meteorological sources. It is expressed in either degrees Celsius or degrees Fahrenheit.

- **Pressure Altitude** is the altitude read from the altimeter when the altimeter's barometric adjustment has been set to 29.92 in.Hg (1013 mb) corrected for position and instrument error. In this Handbook, altimeter instrument errors are assumed to be zero.
- **Standard Temperature** is the temperature that would be found at a given pressure altitude in the standard atmosphere. It is 15° C (59° F) at sea level pressure altitude and decreases approximately 2° C (3.6° F) for each 1000 feet of altitude increase. See ISA definition.

Engine Power Terminology

- HP **Horsepower** is the power developed by the engine.
- MCP **Maximum Continuous Power** is the maximum power that can be used continuously.
- MAP **Manifold Pressure** is the pressure measured in the engine's induction system expressed as in. Hg.
- RPM **Revolutions Per Minute** is engine rotational speed.
- **Static RPM** is RPM attained during a full-throttle engine runup when the airplane is on the ground and stationary.

Performance and Flight Planning Terminology

- g One "g" is a quantity of acceleration equal to that of earth's gravity.
- **Demonstrated Crosswind Velocity** is the velocity of the crosswind component for which adequate control of the airplane during taxi, takeoff, and landing was actually demonstrated during certification testing. Demonstrated crosswind is not considered to be limiting.
 - **Service Ceiling** is the maximum altitude at which the aircraft at maximum weight has the capability of climbing at a rate of 100 feet per minute.
- GPH **Gallons Per Hour** is the amount of fuel (in gallons) consumed by the aircraft per hour.

- NMPG **Nautical Miles Per Gallon** is the distance (in nautical miles) which can be expected per gallon of fuel consumed at a specific engine power setting and/or flight configuration.
- **Unusable Fuel** is the quantity of fuel that cannot be safely used in flight.
 - **Usable Fuel** is the fuel available for flight planning.

Weight and Balance Terminology

- c.g. **Center of Gravity** is the point at which an airplane would balance if suspended. Its distance from the reference datum is found by dividing the total moment by the total weight of the airplane.
- **Arm** is the horizontal distance from the reference datum to the center of gravity (c.g.) of an item. The airplane's arm is obtained by adding the airplane's individual moments and dividing the sum by the total weight.
 - **Basic Empty Weight** is the actual weight of the airplane including all operating equipment that has a fixed location in the airplane. The basic empty weight includes the weight of unusable fuel and full oil.
- MAC **Mean Aerodynamic Chord** is the chord drawn through the centroid of the wing plan area.
- LEMAC **Leading Edge of Mean Aerodynamic Chord** is the forward edge of MAC given in inches aft of the reference datum (fuselage station).
- **Maximum Gross Weight** is the maximum permissible weight of the airplane and its contents as listed in the aircraft specifications.
 - **Moment** is the product of the weight of an item multiplied by its arm.
 - **Useful Load** is the basic empty weight subtracted from the maximum weight of the aircraft. It is the maximum allowable combined weight of pilot, passengers, fuel and baggage.

- **Station** is a location along the airplane fuselage measured in inches from the reference datum and expressed as a number. For example: A point 123 inches aft of the reference datum is Fuselage Station 123.0 (FS 123).
- **Reference Datum** is an imaginary vertical plane from which all horizontal distances are measured for balance purposes.
- **Tare** is the weight of all items used to hold or position the airplane on the scales for weighing. Tare includes blocks, shims, and chocks. Tare weight must be subtracted from the associated scale reading.

Section 2 Limitations

Table of Contents

Introduction	2-3
Certification Status	2-3
Airspeed Limitations	2-4
Airspeed Indicator Markings	2-5
Power Plant Limitations	2-6
Engine.....	2-6
Propeller	2-7
Weight Limits	2-7
Instrument Markings	2-8
Center of Gravity Limits	2-9
Maneuver Limits.....	2-10
Flight Load Factor Limits.....	2-10
Minimum Flight Crew	2-10
Kinds of Operation	2-11
Kinds of Operation Equipment List	2-11
Icing	2-15
Runway Surface	2-15
Taxi Power.....	2-16
Fuel Limits.....	2-16
Altitude Limits.....	2-16
Environmental Conditions	2-16
Maximum Occupancy	2-16
Systems and Equipment Limits.....	2-17
Cirrus Airframe Parachute System (CAPS)	2-17
Primary Flight Display	2-17
Multi-Function Display	2-19
Oxygen System	2-20
Inflatable Restraint System.....	2-20
Flap Limitations.....	2-20
Paint.....	2-20
Other Limitations	2-20
Smoking.....	2-20
Placards	2-21

Intentionally Left Blank

Introduction

• Note •

Limitations associated with optional equipment are not described in this section. For optional equipment limitations, *refer to Section 9, Supplements*

The limitations included in this Section of the Pilot's Operating Handbook (POH) are approved by the Federal Aviation Administration. This section provides operating limitations, instrument markings and basic placards required by regulation and necessary for the safe operation of the SR22 and its standard systems and equipment. *Refer to Section 9* of this handbook for amended operating limitations for airplanes equipped with optional equipment. Compliance with the operating limitations in this section and in Section 9 is required by Federal Aviation Regulations.

Certification Status

The Cirrus SR22 is certificated under the requirements of Federal Aviation Regulations (FAR) Part 23 as documented by FAA Type Certificate TC A00009CH.

Airspeed Limitations

The indicated airspeeds in the following table are based upon Section 5 Airspeed Calibrations using the normal static source. When using the alternate static source, allow for the airspeed calibration variations between the normal and alternate static sources.

Speed	KIAS	KCAS	Remarks
V _{NE}	201	204	Never Exceed Speed is the speed limit that may not be exceeded at any time.
V _{NO}	178	180	Maximum Structural Cruising Speed is the speed that should not be exceeded except in smooth air, and then only with caution.
V _O 3400 Lb	133	135	Operating Maneuvering Speed is the maximum speed at which full control travel may be used. Below this speed the airplane stalls before limit loads are reached. Above this speed, full control movements can damage the airplane.
V _{FE} 50% Flaps 100% Flaps	119 104	120 104	Maximum Flap Extended Speed is the highest speed permissible with wing flaps extended.
V _{PD}	133	135	Maximum Demonstrated Parachute Deployment Speed is the maximum speed at which parachute deployment has been demonstrated.

Figure 2-1
Airspeed Limits

Airspeed Indicator Markings

The airspeed indicator markings are based upon Section 5 Airspeed Calibrations using the normal static source. When using the alternate static source, allow for the airspeed calibration variations between the normal and alternate static sources.

Marking	Value (KIAS)	Remarks
White Arc	59 - 104	Full Flap Operating Range. Lower limit is the most adverse stall speed in the landing configuration. Upper limit is the maximum speed permissible with flaps extended.
Green Arc	70 - 178	Normal Operating Range. Lower limit is the maximum weight stall at most forward C.G. with flaps retracted. Upper limit is the maximum structural cruising speed.
Yellow Arc	178 - 201	Caution Range. Operations must be conducted with caution and only in smooth air.
Red Line	201	Never exceed speed. Maximum speed for all operations.

Figure 2-2
Airspeed Indicator Markings

Power Plant Limitations

Engine

Teledyne Continental IO-550-N

Power Rating 310 hp @ 2700 RPM

Maximum RPM 2700 RPM

Oil:

Oil Temperature 240° F (115° C) maximum

Oil Pressure:

Minimum 10 psi

Maximum 100 psi

Approved Oils:

Engine Break-In: For first 25 hours of operation or until oil consumption stabilizes use straight mineral oil conforming to MIL-L-6082. If engine oil must be added to the factory installed oil, add only MIL-L-6082 straight mineral oil.

After Engine Break-In: Use only oils conforming to Teledyne Continental Specification MHS-24 (Ashless Dispersant Lubrication Oil) or MHS-25 (Synthetic Lubrication Oil). Refer to Section 8 - Oil Servicing. Oil viscosity range as follows:

All Temperatures 15W-50, 20W-50 or 20W-60

Above 40°F (4°C) SAE 50, 20W50, or 20W60

Below 40°F (4°C) SAE 30, 10W30, 15W50, or 20W50

Fuel Grade Aviation Grade 100 LL (Blue) or 100 (green)

• Note •

Refer to General Limitations – Fuel Limits in this section for operational limitations regarding fuel and fuel storage.

Propeller

Hartzell

Propeller Type Constant Speed, Three Blade
Model Number PHC-J3YF-1RF/F7694(B)
Diameter 78.0" (76.0" Minimum)
Model Number PHC-J3YF-1RF/F7693DF(B)
Diameter 78.0" (76.0" Minimum)

or

McCauley

Propeller Type Constant Speed, Three Blade
Model Number D3A34C443/78CYA-0
Diameter 78.0" (76.0" Minimum)

or

MT Propeller

Propeller Type Constant Speed, Three Blade
Model Number MTV-9-D/198-52
Diameter 78.0" (76.0" Minimum)

Weight Limits

Maximum Takeoff Weight 3400 lb (1542 Kg)
Maximum Weight in Baggage Compartment 130 lb (59 Kg)

Instrument Markings

Instrument (Range)	Red Line	Green Arc	Yellow Arc	Red Line
	Minimum	Normal	Caution	Maximum

Power Plant Instrumentation				
Tachometer/ Engine Speed (0 - 3500 RPM)	—	500 - 2700	—	2700
Cylinder Head Temperature (200° F - 500° F)	—	240° - 420° F	420° - 460° F	460° F
Exhaust Gas Temp. (1250° - 1650° F)	—	—	—	—
Manifold Pressure (10 - 30 Inches Hg)	—	15 - 29.5 in. Hg	—	—
Fuel Flow (0 - 30 U.S. Gal./ Hr.)	—	10 - 20 GPH	—	—
Oil Temperature (50° - 240° F)	—	100° - 240° F	—	240° F
Oil Pressure (0 - 100 PSI)	10 psi (Idle)	30 - 60 psi	10 - 30 psi 60 - 100 psi	100 psi (Cold)
Fuel Quantity (0 - 90 U.S. Gallon)	0 gal.	—	0 - 14 gal.	—

Miscellaneous Instrumentation				
Voltmeter (16 - 32 Volts)	—	24 - 30 Volts	—	32 Volts

Figure 2-3
Instrumentation Markings

Center of Gravity Limits

Reference Datum 100 inches forward of firewall

Forward Refer to Figure 2-4

Aft Refer to Figure 2-4

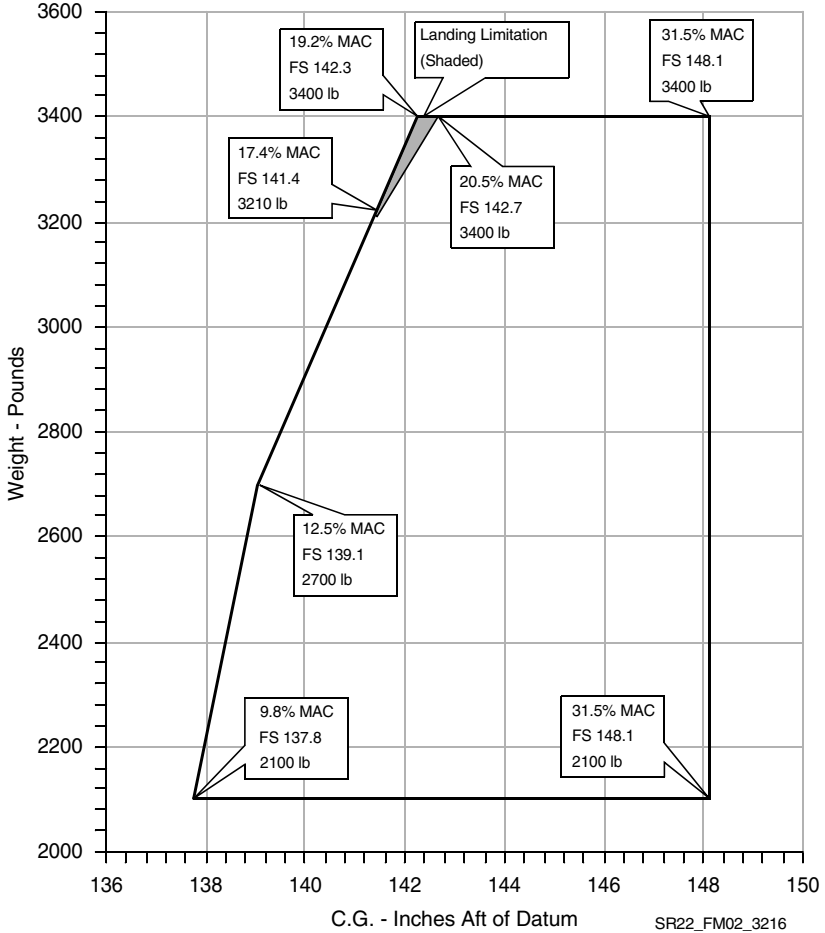

FORWARD LIMIT - The forward limit is FS 137.8 (9.8% MAC) at 2100 lb, with straight line taper to FS 139.1 (12.5% MAC) at 2700 lb, to FS 142.3 (19.2% MAC) at 3400 lb.
AFT LIMIT - The aft limit is FS 148.1 (31.5% MAC) at all weights from 2100 lb to 3400 lb.
LANDING LIMITATION - The Landing Limitation is FS 141.4 (17.4% MAC) at 3210 lb, to FS 142.3 (19.2% MAC) at 3400 lb, to FS 142.7 (20.5% MAC) at 3400 lb, to FS 141.4 (17.4% MAC) at 3210 lb. CAUTION: Before landing, verify aircraft Center of Gravity does not fall in the Landing Limitation Zone. Allow flight time for fuel burn so the landing C.G. falls outside of this zone.

Figure 2-4
C.G. Envelope

Maneuver Limits

Aerobatic maneuvers, including spins, are prohibited.

• Note •

Because the SR22 has not been certified for spin recovery, the Cirrus Airframe Parachute System (CAPS) must be deployed if the airplane departs controlled flight. *Refer to Section 3 – Emergency Procedures, Inadvertent Spiral/Spin Entry.*

This airplane is certified in the normal category and is not designed for aerobatic operations. Only those operations incidental to normal flight are approved. These operations include normal stalls, chandelles, lazy eights, and turns in which the angle of bank is limited to 60°.

Flight Load Factor Limits

Flaps UP (0%), 3400 lb.....	+3.8g, -1.9g
Flaps 50%.....	+1.9g, -0g
Flaps 100% (Down), 3400 lb.	+1.9g, -0g

Minimum Flight Crew

The minimum flight crew is one pilot.

Kinds of Operation

The SR22 is equipped and approved for the following type operations:

- VFR day and night.
- IFR day and night.

Kinds of Operation Equipment List

The following listing summarizes the equipment required under Federal Aviation Regulations (FAR) Part 23 for airworthiness under the listed kind of operation. Those minimum items of equipment necessary under the operating rules are defined in FAR Part 91 and FAR Part 135 as applicable.

• Note •

All references to types of flight operations on the operating limitations placards are based upon equipment installed at the time of Airworthiness Certificate issuance.

System, Instrument, and/or Equipment	Kinds of Operation				Remarks, Notes, and/or Exceptions
	VFR Day	VFR Nt.	IFR Day	IFR Nt.	
Communications					
VHF COM	—	—	1	1	
Electrical Power					
Battery 1	1	1	1	1	
Battery 2	—	—	1	1	
Alternator 1	1	1	1	1	
Alternator 2	—	—	1	1	
Amp Meter/Indication	1	1	1	1	
Low Volts Annunciator	1	1	1	1	
ALT 1 Annunciator	1	1	1	1	
ALT 2 Annunciator	1	1	1	1	

System, Instrument, and/or Equipment	Kinds of Operation				Remarks, Notes, and/or Exceptions	
	VFR Day	VFR Nt.	IFR Day	IFR Nt.		
Circuit Breakers	A/R	A/R	A/R	A/R	As Required. One Seat Belt for each occupant.	
Equipment & Furnishings						
Emergency Locator Transmitter	1	1	1	1		
Restraint System	A/R	A/R	A/R	A/R		
Fire Protection						
Fire Extinguisher	1	1	1	1		
Flight Controls						
Flap Position Lights	3	3	3	3		
Flap System	1	1	1	1		
Pitch Trim Indicator	1	1	1	1		
Pitch Trim System	1	1	1	1		
Roll Trim Indicator	1	1	1	1		
Roll Trim System	1	1	1	1		
Rudder Trim and Indicator	1	1	1	1		Rudder Trim System and/or Indicator may be inoperative provided the trim tab is fixed in the streamlined position, the indicator is placarded "Rudder Trim Inop," and the system is electrically disabled
Stall Warning System	1	1	1	1		
Fuel						
Auxiliary Boost Pump	1	1	1	1		
Fuel Quantity Indicator	2	2	2	2		
Fuel Selector Valve	1	1	1	1		

System, Instrument, and/or Equipment	Kinds of Operation				Remarks, Notes, and/or Exceptions
	VFR Day	VFR Nt.	IFR Day	IFR Nt.	
Ice & Rain Protection					
Alternate Engine Air Induction System	1	1	1	1	
Alternate Static Air Source	1	1	1	1	
Pitot Heater	—	—	1	1	
Landing Gear					
Wheel Pants	—	—	—	—	May be removed.
Lights					
Anticollision Lights	2	2	2	2	
Instrument Lights	—	❖	—	❖	❖-Must be operative.
Navigation Lights	—	2	—	2	
Landing Light	—	1	—	1	For hire operations.
Navigation & Pitot Static					
Airspeed Indicator	1	1	1	1	
Altimeter	1	1	1	1	
Magnetic Compass	1	1	1	1	
Pitot System	1	1	1	1	
Static System, Normal	1	1	1	1	
Attitude Indicator	—	—	1	1	
Clock	—	—	1	1	
Nav Radio	—	—	1	1	
Gyroscopic Directional Indication (HSI)	—	—	1	1	<i>Serials 0002 & subs w/o PFD.</i>

System, Instrument, and/or Equipment	Kinds of Operation				Remarks, Notes, and/or Exceptions
	VFR Day	VFR Nt.	IFR Day	IFR Nt.	
Turn Coordinator	—	—	1	1	<i>Serials 0002 & subs w/o PFD.</i>
PFD Attitude Indication	—	—	1	1	<i>Serials 0435 & subs w/ PFD.</i>
PFD Airspeed Indication	—	—	1	1	<i>Serials 0435 & subs w/ PFD.</i>
PFD Altitude Indication	—	—	1	1	<i>Serials 0435 & subs w/ PFD.</i>
PFD Heading Indication	—	—	1	1	<i>Serials 0435 & subs w/ PFD.</i>
PFD Slip/Skid Indication	—	—	1	1	<i>Serials 0435 & subs w/ PFD.</i>
Magnetometer	—	—	1	1	<i>Serials 0435 & subs w/ PFD.</i>
Vertical Speed Indicator	—	—	—	—	
Multi-Function Display	❖	❖	❖	❖	<i>❖-Serials 1602, 1644, and 1663 thru 2750 before PFD Release 7.0 Software Update; Oil Temperature Indication must be operative.</i>
Engine Indicating					
Cylinder Head Temperature Indication	—	—	—	—	
Exhaust Gas Temperature Indication	—	—	—	—	
Fuel Flow Indication	1	1	1	1	

System, Instrument, and/or Equipment	Kinds of Operation				Remarks, Notes, and/or Exceptions
	VFR Day	VFR Nt.	IFR Day	IFR Nt.	
Manifold Pressure Indication	1	1	1	1	
Oil Pressure Indication	1	1	1	1	
Oil Quantity Indicator (Dipstick)	1	1	1	1	
Oil Temperature Indication	1	1	1	1	
Engine Speed	1	1	1	1	
Special Equipment					
Cirrus Airframe Parachute (CAPS)	1	1	1	1	
Airplane Flight Manual	1	1	1	1	Included w/ POH.

Icing

Flight into known icing conditions is prohibited.

Runway Surface

This airplane may be operated on any smooth runway surface.

• Caution •

Operation on unimproved runway surfaces will cause additional wear and may require additional maintenance or inspection. *Refer to the Airplane Maintenance Manual.*

Taxi Power

Maximum continuous engine speed for taxiing is 1000 RPM on flat, smooth, hard surfaces. Power settings slightly above 1000 RPM are permissible to start motion, for turf, soft surfaces, and on inclines. Use minimum power to maintain taxi speed.

Fuel Limits

Approved Fuel	Aviation Grade 100 LL (Blue) or 100 (Green)
Total Fuel Capacity	84.0 U.S. Gallon (318.0 L)
Total Fuel Each Tank	42.0 U.S. Gallon (159.0 L)
Total Usable Fuel (all flight conditions)	81.0 U.S. Gallon (306.6 L)
Maximum Allowable Fuel Imbalance	10.0 U.S. Gallon (¼ tank)

The fuel system BOOST pump must be on for takeoff, climb, landing, and for switching fuel tanks.

Altitude Limits

Maximum Takeoff Altitude.....	10,000 Feet MSL
Maximum Operating Altitude	17,500 Feet MSL

The operating rules (FAR Part 91 and FAR Part 135) require the use of supplemental oxygen at specified altitudes below the maximum operating altitude. *Refer to Oxygen System Limitations in this Section.*

Environmental Conditions

For operation of the airplane below an outside air temperature of -10°F (-23° C), use of cowl inlet covers approved by Cirrus Design and listed in the Winterization Kit AFM Supplement P/N 13772-118 is required.

Maximum Occupancy

Occupancy of this airplane is limited to four persons (the pilot and three passengers).

Systems and Equipment Limits

Cirrus Airframe Parachute System (CAPS)

V_{PD} Maximum Demonstrated Deployment Speed 133 KIAS

• Note •

Refer to Section 10 – Safety Information, for additional CAPS guidance.

Primary Flight Display

1. The PFD integrates with separately approved sensor installations. Adherence to limitations in appropriate installation POH supplements is mandatory.
2. The Avidyne FlightMax Entegra-Series PFD Pilot's Guide, P/N 600-00142-000, Revision 03, or latest revision, must be available to the pilot during all flight operations.
3. Flight under Instrument Flight Rules (IFR) is not permitted with the PFD or any standby indicator (attitude indicator or magnetic compass) inoperative. *Refer to Kinds of Operation Equipment List.*

• Note •

The Avidyne PFD software version is displayed on the PFD during system startup.

4. *Serials 0002 and subsequent before installation of PFD software version 530-00123-XXX-REV05 (where X can be any digit from 0 to 9):* Backcourse approaches are prohibited.

When the PFD is coupled with Autopilot System, the following Limitations apply:

5. Autopilot operation is prohibited above 185 KIAS.
6. The autopilot must not be engaged for takeoff or landing.
7. The autopilot must be disengaged for missed approach, go-around, and balked landing.
8. Flaps must be set to 50% for autopilot operation in Altitude Hold at airspeeds below 95 KIAS.
9. Flap deflection is limited to 50% during autopilot operations.

10. The autopilot must be disconnected in moderate or severe turbulence.
11. Minimum engage height for the autopilot is 400 ft AGL.

• WARNING •

Autopilot may not be able to maintain all selectable vertical speeds. Selecting a vertical speed that exceeds the aircraft's available performance may cause the aircraft to stall.

12. Minimum speed with the autopilot engaged is $1.2V_s$ for the given configuration.

For VOR/GPS and ILS glideslope and localizer intercept, capture, and tracking, the following limitations apply:

- a. The autopilot must be disengaged no later than 100 feet below the Minimum Descent Altitude
- b. The autopilot must be disconnected during approach if course deviation exceeds 50%. The approach should only be continued by "hand-flying" the airplane.
- c. The autopilot must be disengaged at the Decision Height.
- d. 12 knot maximum crosswind component between the missed approach point and outer marker.
- e. The intercept of the localizer shall occur at least 5 miles outside of the outer marker.
- f. If the crosswind component is greater than 12 knots and less than 17 knots, the intercept shall occur at least 10 miles outside of the outer marker.
- g. The intercept angle shall be no greater than a 45-degree intercept.
- h. The ILS is flown at normal approach speeds, and within any STC or TC speed constraints and as defined in this flight manual.
- i. The flaps should be extended in the approach configuration prior to the Outer Marker. No further changes in the flap configuration should be made throughout the autopilot-coupled approach.

- j. The glideslope is approached in such a manner to allow automatic arming of the glideslope, or if the glideslope is manually armed no more than 15% above the glideslope.

Multi-Function Display

1. The moving map display must not be used as the primary navigation instrument. The moving map display provides visual advisory of the airplane's GPS position against a moving map. The information supplements CDI course deviation and information provided on the GPS navigator.
2. Use of Map page during IFR flight requires an IFR approved GPS receiver installation operated in accordance with applicable limitations.
3. Under no circumstances should the Map page terrain representations be used as a basis for terrain avoidance.
4. The electronic checklists display supplements the Pilot Operating Handbook checklists and is advisory only. The electronic checklists must not be used as the primary set of on-board airplane checklists.
5. The MFD interfaces with separately approved sensor installations. Adherence to limitations in the appropriate sensor installation POH Supplements is mandatory.
6. Traffic information shown on the MAP page display is provided to the pilot as an aid to visually acquire traffic. Pilots should maneuver their aircraft based only on ATC guidance or positive visual acquisition of the conflicting traffic. Maneuver should be consistent with ATC instructions. No maneuvers should be made based solely on a traffic advisory.
7. *Serials with ARNAV MFD installed:* The ARNAV ICDS 2000 Pilot's Operation Handbook, P/N 572-0550 dated May 1998 or later revision, must be available to the pilot during all flight operations
8. *Serials with Avidyne MFD installed:* The Avidyne FlightMax EX5000C Pilot's Guide, P/N 600-00108-000, Revision 03 or later, must be available to the pilot during all flight operations.

Oxygen System

Whenever the operating rules require the use of supplemental oxygen, the pilot must:

- Use an oxygen system approved by Cirrus Design and listed in the Oxygen System AFM Supplement Part Number 13772-109.
- Secure the oxygen bottle in the right front seat as described in the AFM Supplement noted above.

Inflatable Restraint System

Serials 0002 thru 1499, 1501 thru 1519 after SB 2X-25-14 and serials 1500, 1520 and subsequent; Use of a child safety seat with the inflatable restraint system is prohibited.

Air Conditioning System (Optional)

The use of Recirculation Mode during flight is prohibited.

Flap Limitations

Serials 0002 through 0227 before accomplishment of Service Bulletin SB 22-27-02: Simultaneous Flap operation and COM transmission is prohibited.

Approved Takeoff Settings UP (0%) or 50%

Approved Landing Settings Up (0%), 50%, or 100%

Paint

To ensure that the temperature of the composite structure does not exceed 150° F (66° C), the outer surface of the airplane must be painted in accordance with the paint colors and schemes as specified in the Airplane Maintenance Manual. *Refer to Airplane Maintenance Manual (AMM), Chapter 51,* for specific paint requirements.

Other Limitations

Smoking

Smoking is prohibited in this airplane.

Placards

Engine compartment, inside oil filler access:

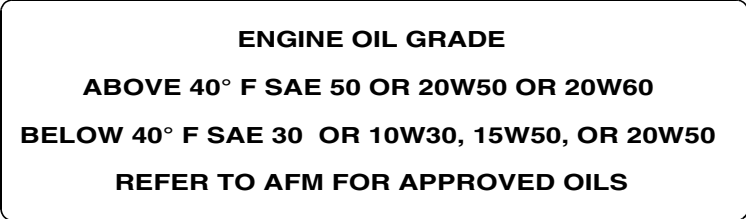

Wing, adjacent to fuel filler caps:

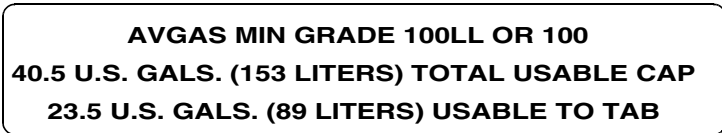

Serials 0002 thru 0549.

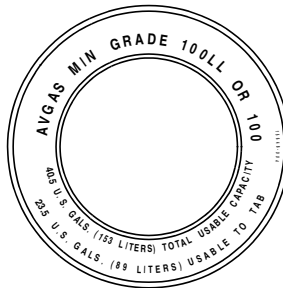

Serials 0550 thru 2333, 2335 thru 2419, 2421 thru 2437.

Upper fuselage, either side of CAPS rocket cover:



SR22_FM02_1372C

Figure 2-5
Placards (Sheet 1 of 7)

Elevator, Rudder, & Elec. Trim Tab (if installed), both sides:



*Left fuselage, on external
power supply door:*

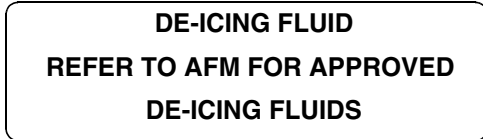
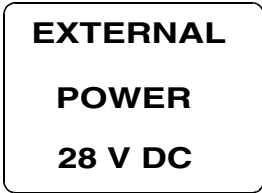

Serials 0334 & subs w/ Ice Protection.

Doors, above and below latch:

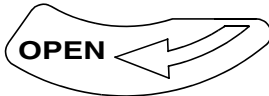
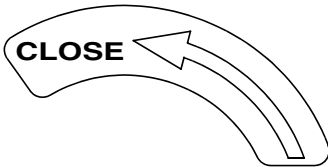

Serials 0002 thru 0521.

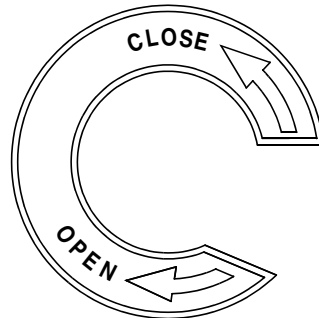

Serials 0522 thru 0820.

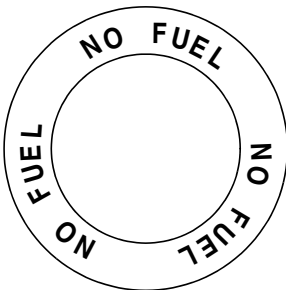

Serials 0334 & subs w/ Ice Protection.

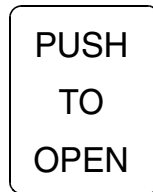

Serials 0821 & subs.

SR22_FM02_1373A

**Figure 2-5
Placards (Sheet 2 of 7)**

Engine control panel:

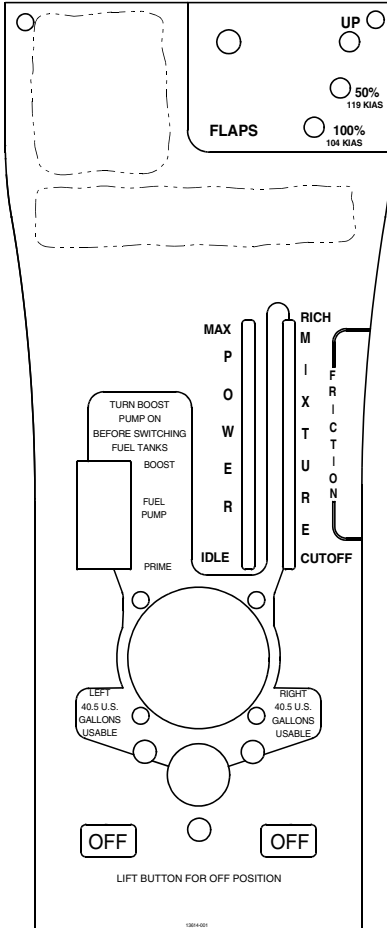

Serials 0002 & subs.

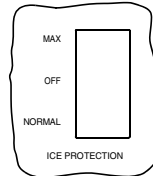

Serials 0334 thru 0434.

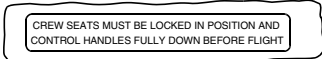

Serials 0410 & subs
& serials 0002 thru 0409
after incorporating SA 02-13.

SR22_FM02_1374C

Figure 2-5
Placards (Sheet 3 of 7)

Wing, flap aft edge and fuselage vortex generator:

NO STEP

Cabin Door Window, lower edge, centered, applied upside down:

RESCUE: FRACTURE AND REMOVE WINDOW

Bolster Switch Panel, left edge:

**THIS AIRCRAFT IS CERTIFIED FOR THE
FOLLOWING FLIGHT OPERATIONS:
DAY - NIGHT - VFR - IFR
(WITH REQUIRED EQUIPMENT)
FLIGHT INTO KNOWN ICING IS PROHIBITED
OPERATE PER AIRPLANE FLIGHT MANUAL**

Instrument Panel Upper left:

**MANEUVERING
SPEED: V_o 133 KIAS**

NORMAL CATEGORY AIRPLANE

**NO ACROBATIC MANEUVERS,
INCLUDING SPINS, APPROVED**

Instrument Panel Upper Right:

ALTITUDE GPH
16000 — 17
12000 — 18
8000 — 21
4000 — 24
SL — 27
MAX POWER FUEL FLOWS

SR22_FM02_1375C

**Figure 2-5
Placards (Sheet 4 of 7)**

Bolster Panel, both sides:



Serials 0656 & subs.

Baggage Compartment, aft edge:

**ELT LOCATED BEHIND BULKHEAD
REMOVE CARPET AND ACCESS PANEL**

Baggage Compartment Door, inside:

**DISTRIBUTED FLOOR LIMIT 130 LBS
BAGGAGE STRAP CAPACITY IS 35 LBS EACH MAXIMUM
SEE AIRPLANE FLIGHT MANUAL FOR BAGGAGE TIE-DOWN
AND WEIGHT AND BALANCE INFORMATION**

12378-001 REV A

SR22_FM02_1376C

**Figure 2-5
Placards (Sheet 5 of 7)**

Instrument Panel:

**FASTEN SEATBELTS
FIRE EXTINGUISHER UNDER PILOT SEAT FRONT
NO SMOKING**

Serials 0002 thru 1862.

**FASTEN SEAT BELT • NO SMOKING
FIRE EXTINGUISHER FORWARD LEFT OF PILOT SEAT**

Serials 1863 & subs.

Cabin Window, above door latch:

**EMERGENCY EXIT
REMOVE EGRESS HAMMER FROM ARMREST LID
STRIKE CORNER OF WINDOW,
KICK OR PUSH OUT AFTER FRACTURING**

Serials 0002 thru 0168.

Cabin Window, above door latch:

**EMERGENCY EXIT
REMOVE EGRESS HAMMER FROM WITHIN
CENTER ARMREST LID. STRIKE CORNER OF
WINDOW. KICK OR PUSH OUT AFTER FRACTURING**

Serials 0169 & subs.

SR22_FM02_1517E

**Figure 2-5
Placards (Sheet 6 of 7)**

CAPS Deployment Handle Cover, above pilot's right shoulder:

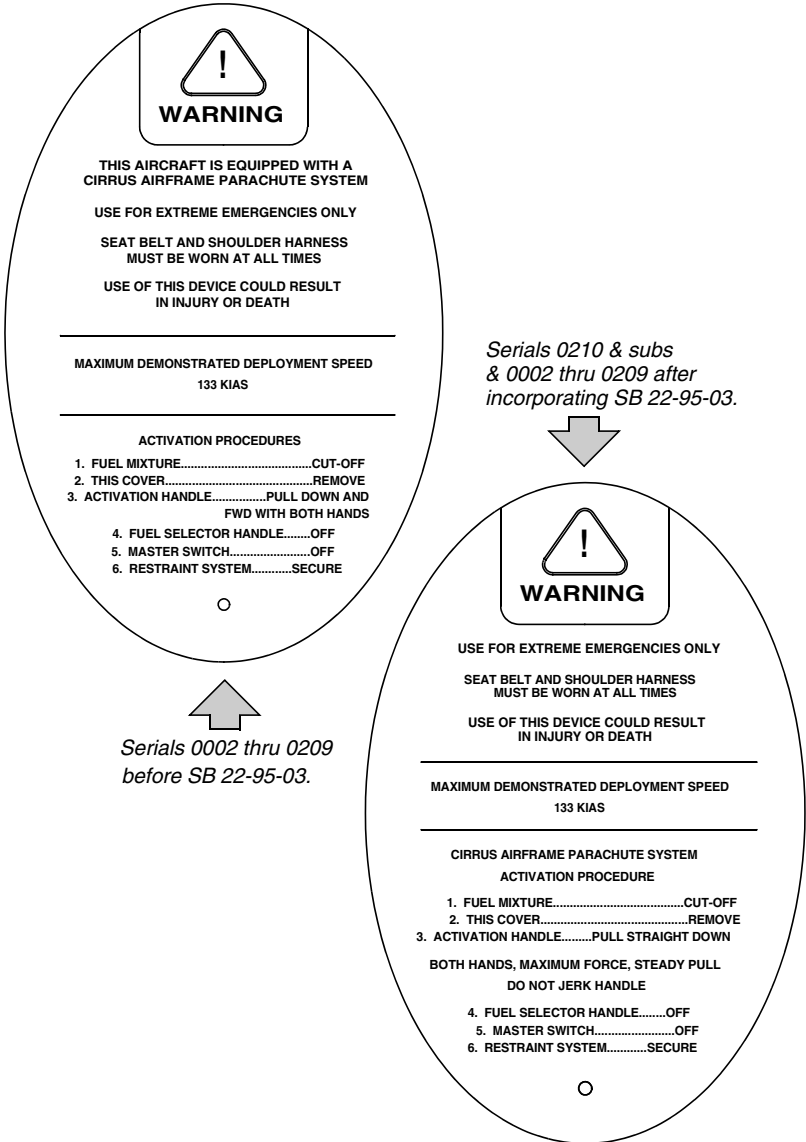

SR22_FM02_1437B

Figure 2-5
Placards (Sheet 7 of 7)

Intentionally Left Blank

Section 3

Emergency Procedures

Table of Contents

Introduction	3-3
Airspeeds for Emergency Operations	3-4
Emergency Procedures Guidance	3-5
Preflight Planning.....	3-5
Preflight Inspections/Maintenance	3-5
Methodology	3-5
Memory Items	3-6
Ground Emergencies	3-7
Engine Fire During Start	3-7
Emergency Engine Shutdown On Ground.....	3-7
Emergency Ground Egress	3-8
In-Flight Emergencies	3-9
Engine Failure On Takeoff (Low Altitude).....	3-9
Maximum Glide	3-10
Engine Failure In Flight.....	3-11
Engine Airstart	3-12
Engine Partial Power Loss.....	3-13
Low Oil Pressure	3-15
Propeller Governor Failure	3-15
Smoke and Fume Elimination.....	3-16
Engine Fire In Flight.....	3-16
Wing Fire In Flight.....	3-16
Cabin Fire In Flight	3-17
Emergency Descent	3-18
Inadvertent Spiral Dive During IMC Flight	3-19
Spins	3-20
CAPS Deployment.....	3-21
Landing Emergencies	3-24
Emergency Landing Without Engine Power	3-24
Ditching.....	3-25
Landing Without Elevator Control	3-25
System Malfunctions.....	3-26
Primary Flight Display System.....	3-26

Section 3
Emergency Procedures

Cirrus Design
SR22

PFD - Loss of Air Data3-26
PFD - Loss of Attitude Data3-26
Power Lever Linkage Failure3-27

Introduction

This section provides procedures for handling emergencies and critical flight situations that may occur while operating the SR22. Although emergencies caused by airplane, systems, or engine malfunctions are extremely rare, the guidelines described in this section should be considered and applied as necessary should an emergency arise.

• Note •

Emergency procedures associated with optional systems can be found in Section 9.

Airspeeds for Emergency Operations

Maneuvering Speed:

3400 lb 133 KIAS

Best Glide:

3400 lb 88 KIAS

2900 lb 87 KIAS

Emergency Landing (Engine-out):

Flaps Up..... 90 KIAS

Flaps 50% 85 KIAS

Flaps 100% 80 KIAS

Emergency Procedures Guidance

Although this section provides procedures for handling most emergencies and critical flight situations that could arise in the SR22, it is not a substitute for thorough knowledge of the airplane and general aviation techniques. A thorough study of the information in this handbook while on the ground will help you prepare for time-critical situations in the air.

Preflight Planning

Enroute emergencies caused by weather can be minimized or eliminated by careful flight planning and good judgment when unexpected weather is encountered.

Preflight Inspections/Maintenance

In-flight mechanical problems in the SR22 will be extremely rare if proper preflight inspections and maintenance are practiced. Always perform a thorough walk-around preflight inspection before any flight to ensure that no damage occurred during the previous flight or while the airplane was on the ground. Pay special attention to any oil leaks or fuel stains that could indicate engine problems.

Methodology

Aircraft emergencies are very dynamic events. Because of this, it is impossible to address every action a pilot might take to handle a situation. However, four basic actions can be applied to any emergency. They are:

Maintain Aircraft Control — Many minor aircraft emergencies turn into major ones when the pilot fails to maintain aircraft control. Remember, do not panic and do not fixate on a particular problem. Over-attention to a faulty warning light during an instrument approach can lead to a pilot induced unusual attitude and possibly worse. To avoid this, even in an emergency: aviate, navigate, and communicate, in this order. Never let anything interfere with your control of the airplane. Never stop flying.

Analyze the Situation — Once you are able to maintain control of the aircraft, assess the situation. Look at the engine parameters. Listen to the engine. Determine what the airplane is telling you.

Take Appropriate Action — In most situations, the procedures listed in this section will either correct the aircraft problem or allow safe recovery of the aircraft. Follow them and use good pilot judgment.

The Cirrus Airframe Parachute System (CAPS) should be activated in the event of a life-threatening emergency where CAPS deployment is determined to be safer than continued flight and landing. *Refer to Section 10, Safety Information*, for CAPS deployment information and landing considerations.

Land as soon as Conditions Permit — Once you have handled the emergency, assess your next move. Handle any non-critical “clean-up” items in the checklist and put the aircraft on the ground. Remember, even if the airplane appears to be in sound condition, it may not be.

Memory Items

Checklist steps emphasized by underlining such as this:

1. Best Glide Speed ESTABLISH
should be memorized for accomplishment without reference to the procedure.

Ground Emergencies

Engine Fire During Start

A fire during engine start may be caused by fuel igniting in the fuel induction system. If this occurs, attempt to draw the fire back into the engine by continuing to crank the engine.

1. Mixture CUTOFF
2. Fuel Pump OFF
3. Fuel Selector OFF
4. Power Lever FORWARD
5. Starter CRANK
6. If flames persist, perform *Emergency Engine Shutdown on Ground* and *Emergency Ground Egress* checklists.

Emergency Engine Shutdown On Ground

1. Power Lever IDLE
2. Fuel Pump (if used) OFF
3. Mixture CUTOFF
4. Fuel Selector OFF
5. Ignition Switch OFF
6. Bat-Alt Master Switches OFF

Emergency Ground Egress

• **WARNING** •

While exiting the airplane, make sure evacuation path is clear of other aircraft, spinning propellers, and other hazards.

1. Engine.....SHUTDOWN

• Note •

If the engine is left running, set the Parking Brake prior to evacuating the airplane.

2. Seat belts.....RELEASE
3. Airplane.....EXIT

• Note •

If the doors cannot be opened, break out the windows with egress hammer, located in the console between the front seats, and crawl through the opening.

In-Flight Emergencies

Engine Failure On Takeoff (Low Altitude)

If the engine fails immediately after becoming airborne, abort on the runway if possible. If altitude precludes a runway stop but is not sufficient to restart the engine, lower the nose to maintain airspeed and establish a glide attitude. In most cases, the landing should be made straight ahead, turning only to avoid obstructions. After establishing a glide for landing, perform as many of the checklist items as time permits.

• WARNING •

If a turn back to the runway is elected, be very careful not to stall the airplane.

1. Best Glide or Landing Speed (as appropriate) ESTABLISH
2. Mixture CUTOFF
3. Fuel Selector OFF
4. Ignition Switch OFF
5. Flaps AS REQUIRED
If time permits:
6. Power Lever IDLE
7. Fuel Pump OFF
8. Bat-Alt Master Switches OFF
9. Seat Belts ENSURE SECURED

Maximum Glide

Conditions

Power
Propeller
Flaps
Wind

OFF
Windmilling
0% (UP)
Zero

Example:

Altitude	10,000 ft. AGL
Airspeed	Best Glide
<hr/>	
Glide Distance	15.8 NM

Best Glide Speed
3400 lb 88 KIAS
Maximum Glide Ratio ~ 9.6 : 1

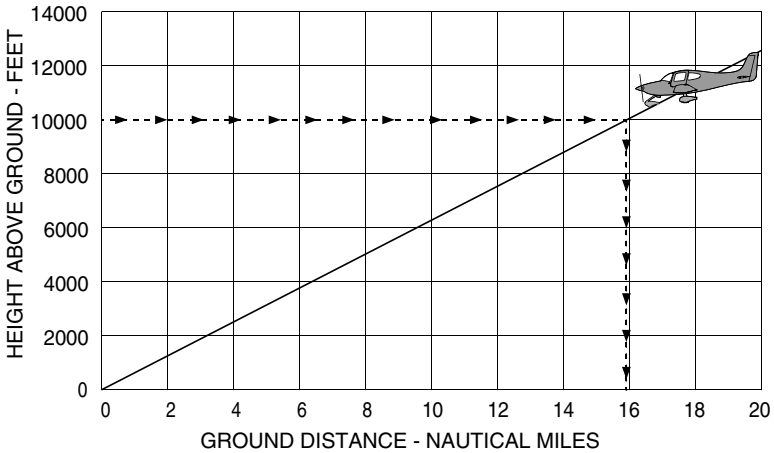

SR22_FM03_1391

Figure 3-1
Maximum Glide

Engine Failure In Flight

If the engine fails at altitude, pitch as necessary to establish best glide speed. While gliding toward a suitable landing area, attempt to identify the cause of the failure and correct it. If altitude or terrain does not permit a safe landing, CAPS deployment may be required. *Refer to Section 10, Safety Information*, for CAPS deployment scenarios and landing considerations.

• WARNING •

If engine failure is accompanied by fuel fumes in the cockpit, or if internal engine damage is suspected, move Mixture Control to CUTOFF and do not attempt a restart.

1. Best Glide Speed ESTABLISH
2. Mixture AS REQUIRED
3. Fuel Selector SWITCH TANKS
4. Fuel Pump BOOST
5. Alternate Induction Air ON
6. Air Conditioner (if installed) OFF
7. Ignition Switch CHECK, BOTH
8. If engine does not start, proceed to *Engine Airstart* or *Forced Landing* checklist, as required.

Engine Airstart

The following procedures address the most common causes for engine loss. Switching tanks and turning the fuel pump on will enhance starting if fuel contamination was the cause of the failure. Leaning the mixture and then slowly enriching mixture may correct faulty mixture control.

• Note •

Engine airstarts may be performed during 1g flight anywhere within the normal operating envelope of the airplane.

1. Bat Master Switches ON
2. Power Lever 1/2" OPEN
3. Mixture RICH, AS REQ'D
4. Fuel Selector SWITCH TANKS
5. Ignition Switch BOTH
6. Fuel Pump BOOST
7. Alternate Induction Air ON
8. Alt Master Switches OFF
9. Starter (Propeller not Windmilling) ENGAGE
10. Power Lever slowly INCREASE
11. Alt Master Switches ON
12. If engine will not start, perform *Forced Landing* checklist.

Engine Partial Power Loss

Indications of a partial power loss include fluctuating RPM, reduced or fluctuating manifold pressure, low oil pressure, high oil temperature, and a rough-sounding or rough-running engine. Mild engine roughness in flight may be caused by one or more spark plugs becoming fouled. A sudden engine roughness or misfiring is usually evidence of a magneto malfunction.

• Note •

Low oil pressure may be indicative of an imminent engine failure – *Refer to Low Oil Pressure* procedure in this section for special procedures with low oil pressure.

• Note •

A damaged (out-of-balance) propeller may cause extremely rough operation. If an out-of-balance propeller is suspected, immediately shut down engine and perform Forced Landing checklist.

If a partial engine failure permits level flight, land at a suitable airfield as soon as conditions permit. If conditions do not permit safe level flight, use partial power as necessary to set up a forced landing pattern over a suitable landing field. Always be prepared for a complete engine failure and consider CAPS deployment if a suitable landing site is not available. *Refer to Section 10, Safety Information*, for CAPS deployment scenarios and landing considerations.

If the power loss is due to a fuel leak in the injector system, fuel sprayed over the engine may be cooled by the slipstream airflow which may prevent a fire at altitude. However, as the Power Lever is reduced during descent and approach to landing the cooling air may not be sufficient to prevent an engine fire.

• WARNING •

If there is a strong smell of fuel in the cockpit, divert to the nearest suitable landing field. Fly a forced landing pattern and shut down the engine fuel supply once a safe landing is assured.

(Continued on following page)

The following procedure provides guidance to isolate and correct some of the conditions contributing to a rough running engine or a partial power loss:

1. Air Conditioner (if installed).....OFF
2. Fuel Pump..... BOOST
Selecting BOOST on may clear the problem if vapor in the injection lines is the problem or if the engine-driven fuel pump has partially failed. The electric fuel pump will not provide sufficient fuel pressure to supply the engine if the engine-driven fuel pump completely fails.
3. Fuel Selector..... SWITCH TANKS
Selecting the opposite fuel tank may resolve the problem if fuel starvation or contamination in one tank was the problem.
4. Mixture CHECK appropriate for flight conditions
5. Power Lever SWEEP
Sweep the Power Lever through range as required to obtain smooth operation and required power.
6. Alternate Induction Air..... ON
A gradual loss of manifold pressure and eventual engine roughness may result from the formation of intake ice. Opening the alternate engine air will provide air for engine operation if the normal source is blocked or the air filter is iced over.
7. Ignition Switch..... BOTH, L, then R
Cycling the ignition switch momentarily from BOTH to L and then to R may help identify the problem. An obvious power loss in single ignition operation indicates magneto or spark plug trouble. Lean the mixture to the recommended cruise setting. If engine does not smooth out in several minutes, try a richer mixture setting. Return ignition switch to the BOTH position unless extreme roughness dictates the use of a single magneto.
8. Land as soon as practical.

Low Oil Pressure

If low oil pressure is accompanied by a rise in oil temperature, the engine has probably lost a significant amount of its oil and engine failure may be imminent. Immediately reduce engine power to idle and select a suitable forced landing field.

• WARNING •

Prolonged use of high power settings after loss of oil pressure will lead to engine mechanical damage and total engine failure, which could be catastrophic.

• Note •

Full power should only be used following a loss of oil pressure when operating close to the ground and only for the time necessary to climb to an altitude permitting a safe landing or analysis of the low oil pressure indication to confirm oil pressure has actually been lost.

If low oil pressure is accompanied by normal oil temperature, it is possible that the oil pressure sensor, gage, or relief valve is malfunctioning. In any case, land as soon as practical and determine cause.

1. Power Lever MINIMUM REQUIRED
2. Land as soon as possible.

Propeller Governor Failure

If the RPM does not respond to power lever movement or overspeeds, the most likely cause is a faulty governor or an oil system malfunction. If moving the power lever is difficult or rough, suspect a power lever linkage failure and perform the *Power Lever Linkage Failure* checklist.

Propeller RPM will not increase:

1. Oil Pressure CHECK
2. Land as soon as practical.

Propeller overspeeds or will not decrease:

1. Power Lever ADJUST (to keep RPM in limits)
2. Airspeed REDUCE to 90 KIAS
3. Land as soon as practical.

Smoke and Fume Elimination

If smoke and/or fumes are detected in the cabin, check the engine parameters for any sign of malfunction. If a fuel leak has occurred, actuation of electrical components may cause a fire. If there is a strong smell of fuel in the cockpit, divert to the nearest suitable landing field. Perform a *Forced Landing* and shut down the fuel supply to the engine once a safe landing is assured.

1. Air Conditioner (if installed).....OFF
2. Temperature Selector.....COLD
3. Vent Selector..... FEET/PANEL/DEFROST POSITION
4. Airflow Selector SET AIRFLOW TO MAXIMUM
If source of smoke and fume is firewall forward:
 - a. Airflow Selector.....OFF
5. Panel Eyeball Outlets.....OPEN
6. Prepare to land as soon as possible.
If airflow is not sufficient to clear smoke or fumes from cabin:
 - a. Cabin Doors..... PARTIALLY OPEN

Engine Fire In Flight

If an engine fire occurs during flight, do not attempt to restart the engine.

1. Mixture CUTOFF
2. Fuel Pump..... OFF
3. Fuel Selector.....OFF
4. Airflow SelectorOFF
5. Power Lever IDLE
6. Ignition Switch.....OFF
7. Cabin Doors PARTIALLY OPEN
Airspeed may need to be reduced to partially open door in flight.
8. Land as soon as possible.

Wing Fire In Flight

1. Pitot Heat Switch OFF
2. Navigation Light Switch..... OFF
3. Landing Light OFF
4. Strobe Light Switch..... OFF
5. If possible, side slip to keep flames away from fuel tank and cabin.

• Note •

Putting the airplane into a dive may blow out the fire. Do not exceed V_{NE} during the dive.

6. Land as soon as possible.

Cabin Fire In Flight

If the cause of the fire is readily apparent and accessible, use the fire extinguisher to extinguish flames and land as soon as possible. Opening the vents or doors may feed the fire, but to avoid incapacitating the crew from smoke inhalation, it may be necessary to rid cabin of smoke or fire extinguishant. If the cause of fire is not readily apparent, is electrical, or is not readily accessible, proceed as follows:

• WARNING •

Serials 0435 and subsequent with PFD: If the airplane is in IMC conditions, turn ALT 1, ALT 2, and BAT 1 switches OFF. Power from battery 2 will keep the Primary Flight Display operational for approximately 30 minutes.

1. Bat-Alt Master Switches..... OFF, AS REQ'D

• Note •

With Bat-Alt Master Switches OFF, engine will continue to run. However, no electrical power will be available.

2. Heater OFF
3. Air Vents..... CLOSED
4. Fire Extinguisher..... ACTIVATE

(Continued on following page)

• **WARNING** •

Halon gas used in the fire extinguisher can be toxic, especially in a closed area. After extinguishing fire, ventilate cabin by opening air vents and unlatching door (if required).

If airflow is not sufficient to clear smoke or fumes from cabin:

5. Cabin Doors PARTIALLY OPEN
Airspeed may need to be reduced to partially open door in flight.
6. When fire extinguished, Air Vents OPEN, FULL COLD
7. Avionics Power Switch OFF
8. All other switches OFF
9. Land as soon as possible.

If setting master switches off eliminated source of fire or fumes and airplane is in night, weather, or IFR conditions:

• **WARNING** •

If airplane is in day VFR conditions and turning off the master switches eliminated the fire situation, leave the master switches OFF. Do not attempt to isolate the source of the fire by checking each individual electrical component.

10. Bat-Alt Master Switches ON
11. Avionics Power Switch ON
12. Activate required systems one at a time. Pause several seconds between activating each system to isolate malfunctioning system. Continue flight to earliest possible landing with malfunctioning system off. Activate only the minimum amount of equipment necessary to complete a safe landing.

Emergency Descent

1. Power Lever IDLE
2. Mixture AS REQUIRED

• **Caution** •

If significant turbulence is expected do not descend at indicated airspeeds greater than V_{NO} (178 KIAS)

3. Airspeed V_{NE} (201 KIAS)

Inadvertent Spiral Dive During IMC Flight

In all cases, if the aircraft enters an unusual attitude from which recovery is not assured, immediately deploy CAPS. *Refer to Section 10, Safety Information*, for CAPS deployment information.

1. Power Lever IDLE
2. Stop the spiral dive by using coordinated aileron and rudder control while referring to the attitude indicator and turn coordinator to level the wings.
3. Cautiously apply elevator back pressure to bring airplane to level flight attitude.
4. Trim for level flight.
5. Set power as required.
6. Use autopilot if functional otherwise keep hands off control yoke, use rudder to hold constant heading.
7. Exit IMC conditions as soon as possible.

Spins

The SR22 is not approved for spins, and has not been tested or certified for spin recovery characteristics. The only approved and demonstrated method of spin recovery is activation of the Cirrus Airframe Parachute System (See *CAPS Deployment*, this section). Because of this, if the aircraft “departs controlled flight,” the CAPS must be deployed.

While the stall characteristics of the SR22 make accidental entry into a spin extremely unlikely, it is possible. Spin entry can be avoided by using good airmanship: coordinated use of controls in turns, proper airspeed control following the recommendations of this Handbook, and never abusing the flight controls with accelerated inputs when close to the stall (see *Stalls*, Section 4).

If, at the stall, the controls are misapplied and abused accelerated inputs are made to the elevator, rudder and/or ailerons, an abrupt wing drop may be felt and a spiral or spin may be entered. In some cases it may be difficult to determine if the aircraft has entered a spiral or the beginning of a spin.

• WARNING •

In all cases, if the aircraft enters an unusual attitude from which recovery is not expected before ground impact, ***immediate*** deployment of the CAPS is required.

The minimum demonstrated altitude loss for a CAPS deployment from a one-turn spin is 920 feet. Activation at higher altitudes provides enhanced safety margins for parachute recoveries. Do not waste time and altitude trying to recover from a spiral/spin before activating CAPS.

Inadvertent Spin Entry

1. CAPS ACTIVATE

CAPS Deployment

The Cirrus Airframe Parachute System (CAPS) should be activated in the event of a life-threatening emergency where CAPS deployment is determined to be safer than continued flight and landing.

• WARNING •

CAPS deployment is expected to result in loss of the airframe and, depending upon adverse external factors such as high deployment speed, low altitude, rough terrain or high wind conditions, may result in severe injury or death to the occupants. Because of this, CAPS should only be activated when any other means of handling the emergency would not protect the occupants from serious injury.

• Caution •

Expected impact in a fully stabilized deployment is equivalent to a drop from approximately 13 feet.

• Note •

Several possible scenarios in which the activation of the CAPS would be appropriate are discussed in Section 10 - Safety Information, of this Handbook. These include:

- Mid-air collision
- Structural failure
- Loss of control
- Landing in inhospitable terrain
- Pilot incapacitation

All pilots should carefully review the information on CAPS activation and deployment in Section 10 before operating the airplane.

Once the decision is made to deploy CAPS, the following actions should be taken:

1. Airspeed..... MINIMUM POSSIBLE

(Continued on following page)

The maximum demonstrated deployment speed is 133 KIAS. Reducing airspeed allows minimum parachute loads and prevents structural overload and possible parachute failure.

2. Mixture (If time and altitude permit) CUTOFF

Generally, a distressed airplane will be safer for its occupants if the engine is not running.

3. Activation Handle Cover..... REMOVE

The cover has a handle located at the forward edge. Pull cover down to expose activation T-handle.

4. Activation Handle (Both Hands) PULL STRAIGHT DOWN

Pull the activation T-handle from its holder. Clasp both hands around the handle and pull straight down in a strong, steady, and continuous motion. Maintain maximum pull force until the rocket activates. Pull forces up to, or exceeding, 45 pounds may be required. Bending of the handle-housing mount is to be expected.

• WARNING •

Jerking or rapidly pulling the activation T-handle will greatly increase the pull forces required to activate the rocket. Use a firm and steady pulling motion – a “chin-up” type pull enhances successful activation.

After Deployment:

5. Mixture CHECK, CUTOFF

6. Fuel Selector OFF

Shutting off fuel supply to engine will reduce the chances of fire resulting from impact at touchdown.

7. Bat-Alt Master Switches OFF

8. Ignition Switch OFF

9. Fuel Pump OFF

10. ELT ON

11. Seat Belts and Harnesses TIGHTEN

(Continued on following page)

All occupants must have seat belts and shoulder harness securely fastened.

12. Loose Items SECURE

If time permits, all loose items should be secured to prevent injury from flying objects in the cabin at touchdown.

13. Assume emergency landing body position.

The emergency landing body position is assumed by placing both hands on the lap, clasping one wrist with the opposite hand, and holding the upper torso erect and against the seat backs.

14. After the airplane comes to a complete stop, evacuate quickly and move upwind.

As occupants exit the airplane, the reduced weight may allow winds to drag the airplane further. As a result of landing impact, the doors may jam. If the doors cannot be opened, break out the windows with the egress hammer, located in the console between the front seats, and crawl through the opening.

Landing Emergencies

If all attempts to restart the engine fail and a forced landing is imminent, select a suitable field and prepare for the landing. If flight conditions or terrain does not permit a safe landing, CAPS deployment may be required. *Refer to Section 10, Safety Information, for CAPS deployment scenarios and landing considerations.*

A suitable field should be chosen as early as possible so that maximum time will be available to plan and execute the forced landing. For forced landings on unprepared surfaces, use full flaps if possible. Land on the main gear and hold the nose wheel off the ground as long as possible. If engine power is available, before attempting an “off airport” landing, fly over the landing area at a low but safe altitude to inspect the terrain for obstructions and surface conditions.

• Note •

Use of full (100%) flaps will reduce glide distance. Full flaps should not be selected until landing is assured.

Emergency Landing Without Engine Power

1. Best Glide Speed ESTABLISH
2. Radio..... Transmit (121.5 MHz) MAYDAY
giving location and intentions
3. Transponder SQUAWK 7700
4. If off airport, ELT ACTIVATE
5. Power Lever IDLE
6. Mixture CUTOFF
7. Fuel Selector OFF
8. Ignition Switch OFF
9. Fuel Pump OFF
10. Flaps (when landing is assured) 100%
11. Master Switches OFF
12. Seat Belt(s) SECURED

Ditching

1. Radio Transmit (121.5 MHz) MAYDAY giving location and intentions
2. Transponder SQUAWK 7700
3. CAPS ACTIVATE
If available, life preservers should be donned and life raft should be prepared for immediate evacuation upon touchdown.
Consider unlatching a door prior to assuming the emergency landing body position in order to provide a ready escape path.
4. Airplane.....EVACUATE
It may be necessary to allow some cabin flooding to equalize pressure on the doors. If the doors cannot be opened, break out the windows with the egress hammer and crawl through the opening.
5. Flotation Devices INFLATE WHEN CLEAR OF AIRPLANE

Landing Without Elevator Control

The pitch trim spring cartridge is attached directly to the elevator and provides a backup should you lose the primary elevator control system. Set elevator trim for a 80 KIAS approach to landing. Thereafter, do not change the trim setting until in the landing flare. During the flare, the nose-down moment resulting from a power reduction may cause the airplane to hit on the nosewheel. At touchdown, bring the power lever to idle.

1. Flaps SET 50%
2. Trim SET 80 KIAS
3. Power AS REQUIRED FOR GLIDE ANGLE

System Malfunctions

Primary Flight Display System

In the unlikely event of a PFD failure, the pilot may lose the ability to control the autopilot through the PFD controls. If this malfunction occurs, the PFD circuit breakers may be pulled and the airplane flown using the mechanical standby instruments. With the PFD circuit breakers pulled, autopilot lateral control is available in GPSS steering mode through GPS 1 and autopilot vertical control is available through the Vertical Speed (VS) and Altitude (ALT) modes on the autopilot head. Dim brightness level to black if PFD is found distracting.

PFD - Loss of Air Data

In the event the PFD detects a loss of air data, the affected indicator is removed from the display and replaced with a red "X". If loss of air data occurs, refer to the mechanical standby instruments (altitude, airspeed) and perform the following procedure:

1. Land as soon as practical.
2. Standby Instruments (altitude, airspeed) MONITOR
If failure occurs while flying in IMC:
3. Exit IMC.

PFD - Loss of Attitude Data

In the event the PFD detects a loss of attitude data, the affected indicator is removed from the display and replaced with a red "X". If loss of attitude data occurs, refer to the mechanical standby instruments (attitude, heading) and perform the following procedure:

1. Standby Instruments (attitude, heading) MONITOR
If failure occurs while flying in IMC:
2. Autopilot GPSS Mode ACTIVATE
3. Autopilot Altitude Hold ACTIVATE
4. Exit IMC.

• WARNING •

Aircraft equipped with Software Version 530-00123-000 Rev 00 or higher; Any power interruption to the PFD will result in

loss of attitude information until the PFD can be restarted on the ground.

Aircraft equipped with Software Version 530-00159-000 Rev 00 or higher; When subjected to a power loss of less than 20 seconds, the PFD is capable of performing a warm start. In this event, a “PLEASE STANDBY” message will be displayed for 2 seconds followed by a “ATTEMPTING QUICK RESTART” message. In the event of a power loss greater than 20 seconds, a warm start is unlikely, and the power interruption will result in loss of attitude information until the PFD can be restarted on the ground.

Power Lever Linkage Failure

If the Power Lever linkage fails in flight, the engine will not respond to power lever control movements. Use power available and flaps as required to safely land the airplane.

If the power lever is stuck at or near the full power position, proceed to a suitable airfield. Fly a forced landing pattern. With landing assured, shut down engine by moving mixture control full aft to CUTOFF. If power is needed again, return mixture control to full RICH and regain safe pattern parameters or go-around. If airspeed cannot be controlled, shut engine down and perform the *Forced Landing* checklist. After landing, bring the airplane to a stop and complete the *Emergency Engine Shutdown on Ground* checklist.

If the power lever is stuck at or near the idle position and straight and level flight cannot be maintained, establish glide to a suitable landing surface. Fly a forced landing pattern.

1. Power Lever Movement..... VERIFY
2. PowerSET if able
3. Flaps SET if needed
4. Mixture AS REQUIRED (full rich to cut-off)
5. Land as soon as possible.

Intentionally Left Blank

Section 3A

Abnormal Procedures

Table of Contents

Introduction	3A-3
Abnormal Procedures Guidance	3A-4
Ground Procedures.....	3A-5
Brake Failure During Taxi	3A-5
Aborted Takeoff	3A-5
In-Flight Procedures.....	3A-6
Inadvertent Icing Encounter.....	3A-6
Inadvertent IMC Encounter.....	3A-6
Door Open In Flight	3A-6
Landing Procedures.....	3A-7
Landing With Failed Brakes.....	3A-7
Landing With Flat Tire.....	3A-7
System Malfunctions.....	3A-9
Alternator Failure	3A-9
Engine Indicating System Failure	3A-11
LOW VOLTS Warning Light Illuminated	3A-11
Communications Failure	3A-12
Pitot Static Malfunction	3A-13
Electric Trim/Autopilot Failure	3A-14

Intentionally Left Blank

Introduction

This section provides procedures for handling abnormal system and/or flight conditions which, if followed, will maintain an acceptable level of airworthiness or reduce operational risk. The guidelines described in this section are to be used when an abnormal condition exists and should be considered and applied as necessary.

Abnormal Procedures Guidance

Although this section provides procedures for handling most abnormal system and/or flight conditions that could arise in the SR22, it is not a substitute for thorough knowledge of the airplane and general aviation techniques. A thorough study of the information in this handbook while on the ground will help you prepare for time-critical situations in the air.

Sound judgement as well as thorough knowledge of the aircraft, its characteristics, and the flight manual procedures are essential in the handling of any abnormal system and/or flight condition. In addition to the outlined items in the Abnormal Procedures, the following steps are considered part of all abnormal situations:

- Maintain Aircraft Control
- Analyze the Situation
- Take Appropriate Action

Ground Procedures

Brake Failure During Taxi

Ground steering is accomplished by differential braking. However, increasing power may allow some rudder control due to increased groundspeed and airflow over the rudder.

1. Engine Power..... AS REQUIRED
 - To stop airplane - REDUCE
 - If necessary for steering - INCREASE
 2. Directional ControlMAINTAIN WITH RUDDER
 3. Brake Pedal(s)PUMP
- If directional control can not be maintained:*
4. MixtureCUTOFF

Aborted Takeoff

Use as much of the remaining runway as needed to safely bring the airplane to a stop or to slow the airplane sufficiently to turn off the runway.

1. Power Lever IDLE
2. Brakes..... AS REQUIRED

• Caution •

For maximum brake effectiveness, retract flaps, hold control yoke full back, and bring the airplane to a stop by smooth, even application of the brakes to avoid loss of control and/or a blown tire.

After a high-speed aborted takeoff, brake temperatures will be elevated; subsequent aborted takeoffs or other high-energy use of the brakes may cause brake overheat, failure and possibly even fire. A 25-minute cooling time is recommended following high-energy use of the brake system before attempting to conduct operations that may require further high-energy braking. Brake temperature indicator should be inspected prior to flight following a high-energy brake event (refer to Preflight Walk-Around Checklist for detail).

In-Flight Procedures

Inadvertent Icing Encounter

Flight into known icing conditions is prohibited. However, If icing is inadvertently encountered:

1. Pitot Heat ON
2. Exit icing conditions. Turn back or change altitude.
3. Cabin Heat MAXIMUM
4. Windshield Defrost FULL OPEN
5. Alternate Induction Air ON

Inadvertent IMC Encounter

Upon entering IMC, a pilot who is not completely proficient in instrument flying should rely upon the autopilot to execute a 180° turn to exit the conditions. Immediate action should be made to turn back as follows:

1. Airplane Control Establish Straight and Level Flight
2. Autopilot Engage to hold Heading and Altitude
3. Heading Reset to initiate 180° turn

Door Open In Flight

The doors on the airplane will remain 1-3 inches open in flight if not latched. If this is discovered on takeoff roll, abort takeoff if practical. If already airborne do not allow efforts to close the door interfere with the primary task of maintaining control of the airplane. Do not attempt to hold door closed. Upon landing flare door may swing open - do not attempt to close door.

1. Airplane Control MAINTAIN

Landing Procedures

Landing With Failed Brakes

One brake inoperative

1. Land on the side of runway corresponding to the inoperative brake.
2. Maintain directional control using rudder and working brake.

Both brakes inoperative

1. Divert to the longest, widest runway with the most direct headwind.
2. Land on downwind side of the runway.
3. Use the rudder for obstacle avoidance.

• Note •

Rudder effectiveness will decrease with decreasing airspeed.

4. Perform *Emergency Engine Shutdown on Ground* checklist.

Landing With Flat Tire

If a flat tire or tread separation occurs during takeoff and you cannot abort, land as soon as conditions permit.

Main Gear

1. Land on the side of the runway corresponding to the good tire.
2. Maintain directional control with the brakes and rudder.
3. Do not taxi. Stop the airplane and perform a normal engine shutdown.

Nose Gear

1. Land in the center of the runway.
2. Hold the nosewheel off the ground as long as possible.
3. Do not taxi. Stop the airplane and perform a normal engine shutdown.

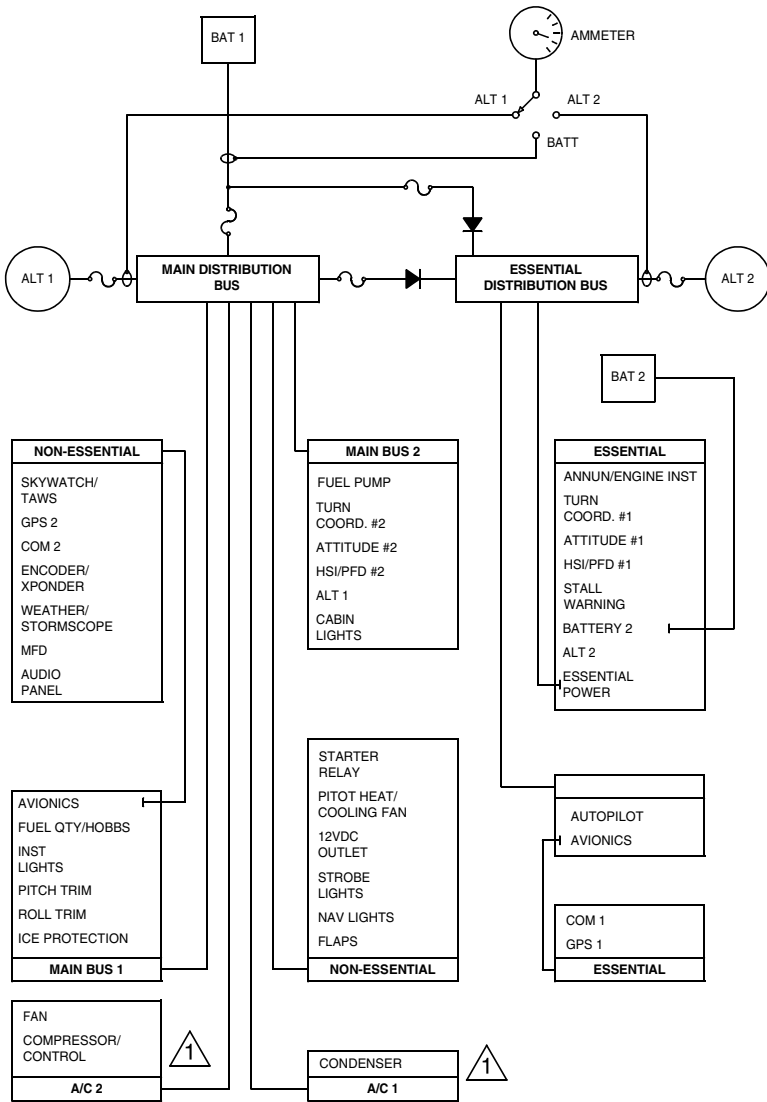

NOTE

1 Serials 1602, 1821, 1840, 1863 & subs with optional Air Conditioning system installed.

SR22_FM03_1453D

Figure 3A-1
Electrical Power Distribution (Simplified)

System Malfunctions

Alternator Failure

Steady illumination of either ALT caution light in the annunciator panel indicates a failure of the corresponding alternator. The most likely the cause of the alternator failure is a wiring fault, a malfunctioning alternator, or a malfunctioning control unit. Usually, electrical power malfunctions are accompanied by an excessive rate of charge or a discharge rate shown on the ammeter.

• Caution •

Alternators in this airplane are self-exciting. These alternators require battery power for alternator starting; however, once started, the alternators will provide self-generated field power to continue operation in case of a battery failure. To assure alternator restart power is available if the alternators fail, the batteries should not be turned off during flight.

Serials 0002 thru 1643 and 1645 thru 1666: A flashing ALT 1 light indicates an excessive charging rate. This could occur with a very low BAT 1 and heavy equipment loads. Since the loads on ALT 2 are much lower, it is unlikely that a flashing ALT 2 light could occur, even with a very low BAT 2.

The Power Distribution Schematic shows the electrical system power distribution. Individual loads on each circuit breaker panel bus are shown in the same order as they are on the panel. Note that items on the circuit breaker panel Essential buses are powered from ALT 1, ALT 2, BAT 1, and BAT 2. The circuit breaker panel Main buses and Non-Essential buses are powered from ALT 1 and BAT 1 only.

• Note •

If it is necessary to reduce electrical loads due to an alternator malfunction, switch off electrical components and/or systems that are not essential for the current flight conditions rather than pulling circuit breakers. Load shedding in this manner will prevent accidental circuit breaker disconnection and loss of power to flight-critical systems. See Figure Electrical Power Distribution, for details on electrical busses and what components/systems they power.

ALT 1 Light Steady

Steady illumination indicates a failure of ALT 1. Attempt to bring alternator back on line. If alternator cannot be brought back, reduce loads and use Main Bus or Non-Essential loads only as necessary for flight conditions.

1. ALT 1 Master SwitchOFF
2. Alternator 1 Circuit Breaker..... CHECK and RESET
3. ALT 1 Master Switch ON

If alternator does not reset:

4. Switch off unnecessary equipment on Main Bus 1, Main Bus 2, and the Non-Essential Buses to reduce loads. Monitor voltage.
5. ALT 1 Master SwitchOFF
6. Land as soon as practical.

ALT 1 Light Flashing

I *Serials 0002 thru 1643 and 1645 thru 1666:* The most likely cause is a severely discharged battery along with heavy equipment loads. In this event, reduce loads on Main and Non-Essential buses and monitor amperage until charging rate is within normal limits. Then loads can be added as required.

1. Ammeter Switch BATT
2. If charging rate is greater than 30 amps, reduce load on Main Bus 1, Main Bus 2, and Non-Essential buses.
3. Monitor ammeter until battery charge rate is less than 15 amps.
4. When battery charge rate is within limits, add loads as necessary for flight conditions.

ALT 2 Light Steady

Except during low RPM operations, steady illumination indicates a failure of ALT 2. If alternator cannot be brought back, Essential bus loads will be powered from ALT 1, BAT 1, and BAT 2.

• Note •

ALT 2 light will illuminate steady and ALT 2 will not come on line until 1700 - 2200 RPM.

1. ALT 2 Master SwitchOFF

2. Alternator 2 Circuit Breaker CHECK and RESET
3. ALT 2 Master SwitchON

If alternator does not reset:

4. Switch off unnecessary equipment on Main Bus 1, Main Bus 2, and Non-Essential Buses to reduce loads.
5. ALT 2 Master Switch OFF
6. Land as soon as practical.

Engine Indicating System Failure

Serials 1644, 1663 and Subsequent: In the event of an Data Acquisition Unit (DAU) failure, the engine indications displayed on the MFD and PFD will be disabled. Numeric readouts will display as three white dashes, the CHT and EGT bar graphs will be removed, and indicator needles displayed on the simulated gages will be removed.

In the event of DAU failure, pull and reset the ANNUN / ENGINE INST circuit breaker. If the engine indicating system fails to reset, land as soon as practical.

1. ANNUN / ENGINE INST Circuit Breaker Cycle
2. Land as soon as practical.

LOW VOLTS Warning Light Illuminated

Illumination of the LOW VOLTS light indicates that the voltage measured at the Essential Bus is 24.5 volts or less. Typically, this indicates that the airplane is operating on battery power only and both alternators have failed or are off. If both alternators have failed:

1. Land as soon as practical.

Communications Failure

Communications failure can occur for a variety of reasons. If, after following the checklist procedure, communication is not restored, proceed with FAR/AIM lost communications procedures.

• Note •

In the event of an audio panel power failure the audio panel connects COM 1 to the pilot's headset and speakers. Setting the audio panel 'Off' will also connect COM 1 to the pilot's headsets and speakers.

1. Switches, Controls CHECK
2. Frequency CHANGE
3. Circuit Breakers..... CHECK
4. Headset..... CHANGE
5. Hand Held Microphone CONNECT

Pitot Static Malfunction

Static Source Blocked

If erroneous readings of the static source instruments (airspeed, altimeter and vertical speed) are suspected, the alternate static source valve, on side of console near pilot’s right ankle, should be opened to supply static pressure from the cabin to these instruments.

• Note •

If selecting the alternate static source does not work, in an emergency, cabin pressure can be supplied to the static pressure instruments by breaking the glass in the face of the vertical speed indicator. When static pressure is supplied through the vertical speed indicator, the vertical speed UP-DOWN indications will be reversed (i.e., the needle will indicate UP for descent and DOWN for climb).

With the alternate static source on, adjust indicated airspeed slightly during climb or approach according to the Airspeed Calibration (Alternate Static Source) table in Section 5 as appropriate for vent/heater configuration.

1. Pitot HeatON
2. Alternate Static Source OPEN

Pitot Tube Blocked

If only the airspeed indicator is providing erroneous information, and in icing conditions, the most probable cause is pitot ice. If setting Pitot Heat ON does not correct the problem, descend to warmer air. If an approach must be made with a blocked Pitot tube, use known pitch and power settings and the GPS groundspeed indicator, taking surface winds into account.

1. Pitot HeatON

Electric Trim/Autopilot Failure

Any failure or malfunction of the electric trim or autopilot can be overridden by use of the control yoke. If runaway trim is the problem, de-energize the circuit by pulling the circuit breaker (PITCH TRIM, ROLL TRIM, or AUTOPILOT) and land as soon as conditions permit.

1. Airplane Control MAINTAIN MANUALLY
2. Autopilot (if engaged) Disengage

If Problem Is Not Corrected:

3. Circuit Breakers..... PULL AS Required
 - PITCH TRIM
 - ROLL TRIM
 - AUTOPILOT
4. Power Lever AS REQUIRED
5. Control Yoke MANUALLY HOLD PRESSURE
6. Land as soon as practical.

Section 4

Normal Procedures

Table of Contents

Introduction	4-3
Airspeeds for Normal Operation	4-4
Normal Procedures	4-5
Preflight Inspection	4-5
Preflight Walk-Around	4-6
Before Starting Engine	4-10
Starting Engine	4-11
Before Taxiing	4-13
Taxiing	4-13
Before Takeoff	4-14
Maximum Power Fuel Flow	4-16
Takeoff	4-17
Normal Takeoff	4-17
Short Field Takeoff	4-18
Climb	4-18
Cruise	4-19
Cruise Leaning	4-20
Descent	4-20
Before Landing	4-20
Landing	4-21
Balked Landing/Go-Around	4-22
After Landing	4-22
Shutdown	4-23
Stalls	4-24
Environmental Considerations	4-25
Cold Weather Operation	4-25
Hot Weather Operation	4-27
Noise Characteristics/Abatement	4-28
Fuel Conservation	4-29

Intentionally Left Blank

Section 4 - Normal Procedures

Normal Procedures

Cruise

Normal cruising is performed between 55% and 85% power. The engine power setting and corresponding fuel consumption for various altitudes and temperatures can be determined by using the cruise data in Section 5.

The selection of cruise altitude is made based on the most favorable wind conditions and the desired power settings. These significant factors should be considered on every trip to reduce fuel consumption.

• Note •

For engine break-in, cruise at a minimum of 75% power until the engine has been operated for at least 25 hours or until oil consumption has stabilized. Operation at this higher power will ensure proper seating of the rings, is applicable to new engines, and engines in service following cylinder replacement or top overhaul of one or more cylinders.

- 1. Fuel Pump OFF

• Note •

The Fuel Pump may be used for vapor suppression during cruise.

The Fuel Pump must be set to BOOST during maneuvering flight (i.e. flight training maneuvers, chandelles, stalls, etc.).

- 2. Cruise Power SET
- 3. Mixture LEAN as required
- 4. Engine Parameters MONITOR

• Note •

Fuel BOOST must be used for switching from one tank to another. Failures to activate the Fuel Pump before transfer could result in delayed restart if the engine should quit due to fuel starvation.

- 5. Fuel Flow and Balance MONITOR

Intentionally Left Blank

Introduction

This section provides amplified procedures for normal operation. Normal procedures associated with optional systems can be found in Section 9.

Airspeeds for Normal Operation

Unless otherwise noted, the following speeds are based on a maximum weight of 3400 lb. and may be used for any lesser weight. However, to achieve the performance specified in Section 5 for takeoff and landing distance, the speed appropriate to the particular weight must be used.

Takeoff Rotation:

- Normal, Flaps 50% 70 KIAS
- Obstacle Clearance, Flaps 50% 78 KIAS

Enroute Climb, Flaps Up:

- Normal 110-120 KIAS
- Best Rate of Climb, SL 101 KIAS
- Best Rate of Climb, 10,000 95 KIAS
- Best Angle of Climb, SL 78 KIAS
- Best Angle of Climb, 10,000 82 KIAS

Landing Approach:

- Normal Approach, Flaps Up 90-95 KIAS
- Normal Approach, Flaps 50% 85-90 KIAS
- Normal Approach, Flaps 100% 80-85 KIAS
- Short Field, Flaps 100% (V_{REF}) 77 KIAS

Go-Around, Flaps 50%:

- Full Power 80 KIAS

Maximum Recommended Turbulent Air Penetration:

- 3400 lb 133 KIAS
- 2900 lb 123 KIAS

Maximum Demonstrated Crosswind Velocity:

- Takeoff or Landing 20 Knots

Normal Procedures

Preflight Inspection

Before carrying out preflight inspections, ensure that all required maintenance has been accomplished. Review your flight plan and compute weight and balance.

• Note •

Throughout the walk-around: check all hinges, hinge pins, and bolts for security; check skin for damage, condition, and evidence of delamination; check all control surfaces for proper movement and excessive free play; check area around liquid reservoirs and lines for evidence of leaking.

In cold weather, remove all frost, ice, or snow from fuselage, wing, stabilizers and control surfaces. Ensure that control surfaces are free of internal ice or debris. Check that wheel fairings are free of snow and ice accumulation. Check that pitot probe warms within 30 seconds of setting Pitot Heat to ON.

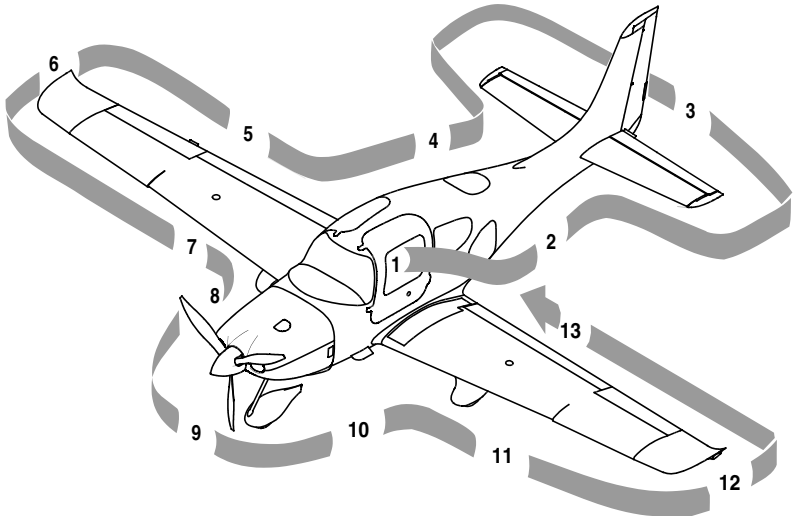

SR22_FM04_1454

Figure 4-1
Walk-Around

Preflight Walk-Around

1. Cabin

- a. Required Documents On Board
- b. Avionics Power Switch OFF
- c. Bat 2 Master Switch ON
- d. PFD - *Serials 0435 and subsequent with PFD* Verify On
- e. Avionics Cooling Fan Audible
- f. Voltmeter 23-25 Volts
- g. Flap Position Light OUT
- h. Bat 1 Master Switch ON
- i. Lights Check Operation
- j. Stall Warning Test

• Note •

Test stall warning system by applying suction to the stall warning system inlet and noting the warning horn sounds.

- k. Fuel Quantity Check
- l. Fuel Selector Select Fullest Tank
- m. Flaps 100%, Check Light ON
- n. Oil Annunciator On
- o. Bat 1 and 2 Master Switches OFF
- p. Alternate Static Source NORMAL
- q. Circuit Breakers IN
- r. Fire Extinguisher Charged and Available
- s. Emergency Egress Hammer Available
- t. CAPS Handle Pin Removed

2. Left Fuselage

- a. Door Lock Unlock
- b. COM 1 Antenna (top) Condition and Attachment
- c. Wing/Fuselage Fairing Check

- d. COM 2 Antenna (underside) Condition and Attachment
 - e. Baggage Door Closed and Secure
 - f. Static Button Check for Blockage
 - g. Parachute Cover Sealed and Secure
3. Empennage
- a. Tiedown Rope Remove
 - b. Horizontal and Vertical Stabilizers Condition

• Note •

Verify tape covering the forward and aft inspection holes located on outboard ends of horizontal stabilizer is installed and securely attached.

- c. Elevator and Tab Condition and Movement
 - d. Rudder Freedom of Movement
 - e. Rudder Trim Tab Condition and Security
 - f. Attachment hinges, bolts and cotter pins Secure
4. Right Fuselage
- a. Static Button Check for Blockage
 - b. Wing/Fuselage Fairings Check
 - c. Door Lock Unlock
5. Right Wing Trailing Edge
- a. Flap and Rub Strips (if installed) Condition and Security
 - b. Aileron and Tab Condition and Movement
 - c. Aileron Gap Seal Security
 - d. Hinges, actuation arm, bolts, and cotter pins Secure
6. Right Wing Tip
- a. Tip Attachment
 - b. Strobe, Nav Light and Lens Condition and Security
 - c. Fuel Vent (underside) Unobstructed

(Continued on following page)

- 7. Right Wing Forward and Main Gear
 - a. Leading Edge and Stall StripsCondition
 - b. Fuel Cap Check Quantity and Secure
 - c. Fuel Drains (2 underside) Drain and Sample
 - d. Wheel Fairings Security, Accumulation of Debris
 - e. TireCondition, Inflation, and Wear

• Caution •

Serials 0002 through 1727 after Service Bulletin SB 2X-32-14 and airplane serials 1728 and subsequent: Clean and inspect temperature indicator installed to piston housing. If indicator center is black, the brake assembly has been overheated. The brake linings must be inspected and O-rings replaced.

- f. Wheel and Brakes Fluid Leaks, Evidence of Overheating, General Condition, and Security.
 - g. Chocks and Tiedown Ropes Remove
 - h. Cabin Air Vent Unobstructed
- 8. Nose, Right Side
 - a. Vortex GeneratorCondition
 - b. Cowling Attachments Secure
 - c. Exhaust PipeCondition, Security, and Clearance
 - d. Transponder Antenna (underside) .. Condition and Attachment
 - e. Gascolator (underside)Drain for 3 seconds, Sample
- 9. Nose gear, Propeller, and Spinner

• WARNING •

Keep clear of propeller rotation plane. Do not allow others to approach propeller.

- a. Tow Bar Remove and Stow
 - b. StrutCondition
 - c. Wheel Fairing Security, Accumulation of Debris
 - d. Wheel and TireCondition, Inflation, and Wear

- e. Propeller Condition (indentations, nicks, etc.)
 - f. Spinner Condition, Security, and Oil Leaks
 - g. Air Inlets Unobstructed
 - h. Alternator Condition
10. Nose, Left Side
- a. Landing Light Condition
 - b. Engine Oil Check 6-8 quarts, Leaks, Cap & Door Secure
 - c. Cowling Attachments Secure
 - d. External Power Door Secure
 - e. Vortex Generator Condition
 - f. Exhaust Pipe(s) Condition, Security, and Clearance
11. Left Main Gear and Forward Wing
- a. Wheel fairings Security, Accumulation of Debris
 - b. Tire Condition, Inflation, and Wear

• Caution •

Serials 0002 through 1727 after Service Bulletin SB 2X-32-14 and airplane serials 1728 and subsequent: Clean and inspect temperature indicator installed to piston housing. If indicator center is black, the brake assembly has been overheated. The brake linings must be inspected and O-rings replaced.

- c. Wheel and Brakes Fluid Leaks, Evidence of Overheating, General Condition, and Security.
 - d. Chocks and Tiedown Ropes Remove
 - e. Fuel Drains (2 underside) Drain and Sample
 - f. Cabin Air Vent Unobstructed
 - g. Fuel Cap Check Quantity and Secure
 - h. Leading Edge and Stall Strips Condition
12. Left Wing Tip
- a. Fuel Vent (underside) Unobstructed
 - b. Pitot Mast (underside) Cover Removed, Tube Clear

(Continued on following page)

- c. Strobe, Nav Light and LensCondition and Security
- d. TipAttachment

13. Left Wing Trailing Edge

- a. Flap And Rub Strips (If installed).....Condition and Security
- b. Aileron Freedom of movement
- c. Aileron Gap Seal Security
- d. Hinges, actuation arm, bolts, and cotter pins Secure

Before Starting Engine

- 1. Preflight Inspection COMPLETED

• WARNING •

Ensure that the airplane is properly loaded and within the AFM's weight and balance limitations prior to takeoff.

- 2. Weight and BalanceVerify within limits
- 3. Emergency Equipment.....ON BOARD
- 4. Passengers BRIEFED

• Note •

Ensure all the passengers have been fully briefed on smoking, the use of the seat belts, doors, emergency exits, egress hammer, and CAPS.

Verify CAPS handle safety pin is removed.

- 5. Seats, Seat Belts, and HarnessesADJUST & SECURE

• Caution •

Crew seats must be locked in position and control handles fully down before flight. Ensure seat belt harnesses are not twisted.

Starting Engine

If the engine is warm, no priming is required. For the first start of the day and in cold conditions, prime will be necessary.

Weak intermittent firing followed by puffs of black smoke from the exhaust stack indicates over-priming or flooding. Excess fuel can be cleared from the combustion chambers by the following procedure:

- Turn fuel pump off.
- Allow fuel to drain from intake tubes.
- Set the mixture control full lean and the power lever full open.
- Crank the engine through several revolutions with the starter.
- When engine starts, release ignition switch, retard power lever, and slowly advance the mixture control to FULL RICH position.

If the engine is under-primed, especially with a cold soaked engine, it will not fire, and additional priming will be necessary. As soon as the cylinders begin to fire, open the power lever slightly to keep it running.

Refer to Cold Weather Operation in this section or additional information regarding cold weather operations.

• WARNING •

If airplane will be started using external power, keep all personnel and power unit cables well clear of the propeller rotation plane.

• Caution •

Alternators should be left OFF during engine starting to avoid high electrical loads.

After starting, if the oil gage does not begin to show pressure within 30 seconds in warm weather and about 60 seconds in very cold weather, shut down engine and investigate cause. Lack of oil pressure indicates loss of lubrication, which can cause severe engine damage.

1. External Power (If applicable) CONNECT
2. Brakes HOLD
3. Bat Master Switches ON (Check Volts)

- 4. Strobe Lights..... ON
- 5. Mixture FULL RICH
- 6. Power Lever FULL FORWARD
- 7. Fuel Pump..... PRIME, then BOOST

• Note •

Serials 0002 - 0278 before SB 22-73-01: On first start of the day, especially under cool ambient conditions, holding Fuel Pump switch to PRIME for 30-60 seconds will improve starting.

Serials 0002 - 0278 after SB 22-73-01 and serials 0279 and subsequent: On first start of the day, especially under cool ambient conditions, holding Fuel Pump switch to PRIME for 2 seconds will improve starting.

- 8. Propeller Area CLEAR
- 9. Power Lever OPEN ¼ INCH
- 10. Ignition Switch..... START (Release after engine starts)

• Caution •

Limit cranking to intervals of 20 seconds with a 20 second cooling period between cranks. This will improve battery and contactor life.

- 11. Power LeverRETARD (to maintain 1000 RPM)
- 12. Oil Pressure CHECK
- 13. Alt Master Switches ON
- 14. Avionics Power Switch ON
- 15. Engine Parameters MONITOR
- 16. External Power (If applicable) DISCONNECT
- 17. Amp Meter/Indication CHECK

Before Taxiing

1. Flaps UP (0%)
2. Radios/Avionics AS REQUIRED
3. Cabin Heat/Defrost AS REQUIRED
4. Fuel Selector SWITCH TANK

Taxiing

When taxiing, directional control is accomplished with rudder deflection and intermittent braking (toe taps) as necessary. Use only as much power as is necessary to achieve forward movement. Deceleration or taxi speed control using brakes but without a reduction in power will result in increased brake temperature. Taxi over loose gravel at low engine speed to avoid damage to the propeller tips.

• WARNING •

Maximum continuous engine speed for taxiing is 1000 RPM on flat, smooth, hard surfaces. Power settings slightly above 1000 RPM are permissible to start motion, for turf, soft surfaces, and on inclines. Use minimum power to maintain taxi speed.

If the 1000 RPM taxi power limit and proper braking procedures are not observed, the brake system may overheat and result in brake damage or brake fire.

1. Parking Brake DISENGAGE
2. Brakes CHECK
3. HSI Orientation CHECK
4. Attitude Gyro CHECK
5. Turn Coordinator CHECK

Before Takeoff

During cold weather operations, the engine should be properly warmed up before takeoff. In most cases this is accomplished when the oil temperature has reached at least 100° F (38° C). In warm or hot weather, precautions should be taken to avoid overheating during prolonged ground engine operation. Additionally, long periods of idling may cause fouled spark plugs.

• WARNING •

Do not takeoff with frost, ice, snow, or other contamination on the fuselage, wing, stabilizers, and control surfaces.

1. DoorsLATCHED
2. CAPS Handle Verify Pin Removed
3. Seat Belts and Shoulder Harness..... SECURE
4. Air Conditioner AS DESIRED

• Note •

If Air Conditioner is ON for takeoff roll, see Section 5, Performance for takeoff distance change. No takeoff distance change is necessary if system remains OFF for takeoff roll.

5. Fuel Quantity..... CONFIRM
6. Fuel Selector..... FULLEST TANK
7. Fuel Pump..... BOOST
8. Mixture AS REQUIRED
9. FlapsSET 50% & CHECK
10. Transponder SET
11. Autopilot CHECK
12. Navigation Radios/GPS SET for Takeoff
13. Cabin Heat/Defrost AS REQUIRED
14. Brakes HOLD
15. Power Lever 1700 RPM
16. Alternator CHECK
 - a. Pitot Heat..... ON

- b. Navigation Lights ON
 - c. Landing Light ON
 - d. Annunciator Lights CHECK
 - Verify both ALT 1 and ALT 2 caution lights out and positive amps indication for each alternator. If necessary, increase RPM to extinguish ALT 2 caution light. ALT 2 caution light should go out below 2200 RPM.
17. Voltage CHECK
18. Pitot Heat AS REQUIRED

• Note •

Pitot Heat should be turned ON for flight into IMC, flight into visible moisture, or whenever ambient temperatures are 41° F (5° C) or less.

19. Navigation Lights AS REQUIRED
20. Landing Light AS REQUIRED
21. Magnetos CHECK Left and Right
- a. Ignition Switch R, note RPM, then BOTH
 - b. Ignition Switch L, note RPM, then BOTH

• Note •

RPM drop must not exceed 150 RPM for either magneto. RPM differential must not exceed 75 RPM between magnetos. If there is a doubt concerning operation of the ignition system, RPM checks at higher engine speeds will usually confirm whether a deficiency exists. An absence of RPM drop may indicate faulty grounding of one side of the ignition system or magneto timing set in advance of the specified setting.

22. Engine Parameters CHECK
23. Power Lever 1000 RPM
24. Flight Instruments, HSI, and Altimeter CHECK & SET
25. Flight Controls FREE & CORRECT
26. Trim SET Takeoff
27. Autopilot DISCONNECT

Maximum Power Fuel Flow

Leaning for Takeoff and Maximum Climb is accomplished at full throttle by leaning the mixture from full rich to the target fuel flow for the given pressure altitude. The fuel flow values in the table below were demonstrated to obtain the takeoff and climb performance presented in Section 5.

• Note •

Excessively rich mixture will occur if the Mixture control is set to FULL RICH above 7500 feet pressure altitude.

Pressure Altitude	Target Fuel Flow	Pressure Altitude	Target Fuel Flow	Pressure Altitude	Target Fuel Flow
0	27.1	7000	21.4	14,000	17.5
1000	26.2	8000	20.5	15,000	16.9
2000	25.1	9000	19.9	16,000	16.7
3000	24.3	10,000	19.5	17,000	16.2
4000	23.6	11,000	18.8	17,500	16.1
5000	22.8	12,000	18.4		
6000	22.1	13,000	17.9		

Takeoff

Power Check: Check full-throttle engine operation early in takeoff run. The engine should run smoothly and turn approximately 2700 RPM. All engine parameters should read in the green. Discontinue takeoff at any sign of rough operation or sluggish acceleration. Make a thorough full-throttle static run-up before attempting another takeoff.

For takeoff over a gravel surface, advance Power Lever slowly. This allows the airplane to start rolling before high RPM is developed, and gravel will be blown behind the propeller rather than pulled into it.

Flap Settings: Normal and short field takeoffs are accomplished with flaps set at 50%. Takeoffs using 0% are permissible, however, no performance data is available for takeoffs in the flaps up configuration. Takeoffs with 100% flaps are not approved.

Soft or rough field takeoffs are performed with 50% flaps by lifting the airplane off the ground as soon as practical in a tail-low attitude. If no obstacles are ahead, the airplane should be leveled off immediately to accelerate to a higher climb speed.

Takeoffs into strong crosswinds are normally performed with the flaps set at 50% to minimize the drift angle immediately after takeoff. With the ailerons fully deflected into the wind, accelerate the airplane to a speed slightly higher than normal while decreasing the aileron deflection as speed increases then - with authority - rotate to prevent possibly settling back to the runway while drifting. When clear of the ground, make a coordinated turn into the wind to correct for drift.

• Note •

Fuel BOOST should be left ON during takeoff and for climb as required for vapor suppression with hot or warm fuel.

Normal Takeoff

1. Brakes..... RELEASE (Steer with Rudder Only)
2. Power Lever FULL FORWARD
3. Engine Parameters CHECK
4. Elevator Control ROTATE Smoothly at 70-73 KIAS
5. At 80 KIAS, Flaps..... UP

Short Field Takeoff

1. Flaps50%
2. Brakes HOLD
3. Power Lever FULL FORWARD
4. Mixture SET
5. Engine Parameters CHECK
6. Brakes RELEASE (Steer with Rudder Only)
7. Elevator Control ROTATE Smoothly at 70 KIAS
8. Airspeed at Obstacle.....78 KIAS

Climb

Normal climbs are performed flaps UP (0%) and full power at speeds 5 to 10 knots higher than best rate-of-climb speeds. These higher speeds give the best combination of performance, visibility and engine cooling.

For maximum rate of climb, use the best rate-of-climb speeds shown in the rate-of-climb chart in Section 5. If an obstruction dictates the use of a steep climb angle, the best angle-of-climb speed should be used. Climbs at speeds lower than the best rate-of-climb speed should be of short duration to avoid engine-cooling problems.

1. Climb Power SET
2. Flaps Verify UP
3. Mixture LEAN as required for altitude
4. Engine Parameters CHECK
5. Fuel Pump..... BOOST

• Note •

The fuel pump is used for vapor suppression during climb. It is also recommended that the fuel pump be left on after leveling off for 30 minutes following a climb and anytime fuel flow or EGT anomalies occur.

Cruise

Normal cruising is performed between 55% and 85% power. The engine power setting and corresponding fuel consumption for various altitudes and temperatures can be determined by using the cruise data in Section 5.

The selection of cruise altitude is made based on the most favorable wind conditions and the desired power settings. These significant factors should be considered on every trip to reduce fuel consumption.

• Note •

For engine break-in, cruise at a minimum of 75% power until the engine has been operated for at least 25 hours or until oil consumption has stabilized. Operation at this higher power will ensure proper seating of the rings, is applicable to new engines, and engines in service following cylinder replacement or top overhaul of one or more cylinders.

1. Fuel Pump OFF

• Note •

The Fuel Pump may be used for vapor suppression during cruise.

2. Cruise Power..... SET
3. MixtureLEAN as required
4. Engine Parameters MONITOR

• Note •

Fuel BOOST must be used for switching from one tank to another. Failures to activate the Fuel Pump before transfer could result in delayed restart if the engine should quit due to fuel starvation.

5. Fuel Flow and Balance MONITOR

Cruise Leaning

Exhaust gas temperature (EGT) may be used as an aid for mixture leaning in cruise flight. **For “Best Power” use 75% power or less. For “Best Economy” use 65% power or less.** To adjust the mixture, lean to establish the peak EGT as a reference point and then adjust the mixture by the desired increment based on the following table:

Mixture Description	Exhaust Gas Temperature
Best Power	75° F Rich Of Peak EGT
Best Economy	50° F Lean Of Peak EGT

Under some conditions, engine roughness may occur while operating at best economy. If this occurs, enrich mixture as required to smooth engine operation. Any change in altitude or Power Lever position will require a recheck of EGT indication.

Descent

1. Altimeter SET
2. Cabin Heat/Defrost AS REQUIRED
3. Landing Light ON
4. Fuel System CHECK
5. Mixture AS REQUIRED
6. Brake Pressure CHECK

Before Landing

1. Seat Belt and Shoulder Harness SECURE
2. Fuel Pump BOOST
3. Mixture AS REQUIRED
4. Flaps AS REQUIRED
5. Autopilot AS REQUIRED

Landing

• Caution •

Landings should be made with full flaps. Landings with less than full flaps are recommended only if the flaps fail to deploy or to extend the aircraft's glide distance due to engine malfunction. Landings with flaps at 50% or 0%; power should be used to achieve a normal glidepath and low descent rate. Flare should be minimized.

Before landing, verify aircraft Center of Gravity does not fall in the landing limitation zone as depicted in the C.G. Envelope in section 2. Allow flight time for fuel burn so the landing C.G. falls outside of this zone.

Normal Landing

Normal landings are made with full flaps with power on or off. Surface winds and air turbulence are usually the primary factors in determining the most comfortable approach speeds.

Actual touchdown should be made with power off and on the main wheels first to reduce the landing speed and subsequent need for braking. Gently lower the nose wheel to the runway after airplane speed has diminished. This is especially important for rough or soft field landings.

Short Field Landing

For a short field landing in smooth air conditions, make an approach at 77 KIAS with full flaps using enough power to control the glide path (slightly higher approach speeds should be used under turbulent air conditions). After all approach obstacles are cleared, progressively reduce power to reach idle just before touchdown and maintain the approach speed by lowering the nose of the airplane. Touchdown should be made power-off and on the main wheels first. Immediately after touchdown, lower the nose wheel and apply braking as required. For maximum brake effectiveness, retract the flaps, hold the control yoke full back, and apply maximum brake pressure without skidding.

Crosswind Landing

Normal crosswind landings are made with full flaps. Avoid prolonged slips. After touchdown, hold a straight course with rudder and brakes

as required. The maximum allowable crosswind velocity is dependent upon pilot capability as well as aircraft limitations. Operation in direct crosswinds of 20 knots has been demonstrated.

Balked Landing/Go-Around

In a balked landing (go around) climb, disengage autopilot, apply full power, then reduce the flap setting to 50%. If obstacles must be cleared during the go around, climb at 75-80 KIAS with 50% flaps. After clearing any obstacles, retract the flaps and accelerate to the normal flaps up climb speed.

1. AutopilotDISENGAGE
2. Power LeverFULL FORWARD
3. Flaps50%
4. Airspeed..... 75-80 KIAS

After clear of obstacles:

5. Flaps UP

After Landing

1. Power Lever 1000 RPM
2. Fuel Pump.....OFF
3. Flaps UP
4. Transponder STBY
5. Lights AS REQUIRED
6. Pitot Heat OFF

• Note •

As the airplane slows the rudder becomes less effective and taxiing is accomplished using differential braking.

Shutdown

1. Fuel Pump (if used) OFF
2. Throttle..... IDLE
3. Ignition Switch..... CYCLE

• Caution •

Note that the engine hesitates as the switch cycles through the “OFF” position. If the engine does not hesitate, one or both magnetos are not grounded. Prominently mark the propeller as being “Hot,” and contact maintenance personnel immediately.

4. MixtureCUTOFF
5. All Switches OFF
6. Magnetos OFF
7. ELT TRANSMIT LIGHT OUT

• Note •

After a hard landing, the ELT may activate. If this is suspected, press the RESET button.

8. Chocks, Tie-downs, Pitot Covers AS REQUIRED

Stalls

SR22 stall characteristics are conventional. Power-off stalls may be accompanied by a slight nose bobbing if full aft stick is held. Power-on stalls are marked by a high sink rate at full aft stick. Power-off stall speeds at maximum weight for both forward and aft C.G. positions are presented in Section 5 - Performance Data.

When practicing stalls at altitude, as the airspeed is slowly reduced, you will notice a slight airframe buffet and hear the stall speed warning horn sound between 5 and 10 knots before the stall. Normally, the stall is marked by a gentle nose drop and the wings can easily be held level or in the bank with coordinated use of the ailerons and rudder. Upon stall warning in flight, recovery is accomplished by immediately by reducing back pressure to maintain safe airspeed, adding power if necessary and rolling wings level with coordinated use of the controls.

• WARNING •

Extreme care must be taken to avoid uncoordinated, accelerated or abused control inputs when close to the stall, especially when close to the ground.

Environmental Considerations

Cold Weather Operation

Starting

If the engine has been cold soaked, it is recommended that the propeller be pulled through by hand several times to break loose or limber the oil. This procedure will reduce power draw on the battery if a battery start is made.

When the engine has been exposed to temperatures at or below 20° Fahrenheit (-7° C) for a period of two hours or more, the use of an external pre-heater and external power is recommended. Failure to properly preheat a cold-soaked engine may result in oil congealing within the engine, oil hoses, and oil cooler with subsequent loss of oil flow, possible internal damage to the engine, and subsequent engine failure.

If the engine does not start during the first few attempts, or if engine firing diminishes in strength, the spark plugs have probably frosted over. Preheat must be used before another start is attempted.

• **WARNING** •

If airplane will be started using external power, keep all personnel and power unit cables well clear of the propeller rotation plane.

• **Caution** •

Inadequate application of preheat to a cold soaked engine may warm the engine enough to permit starting but will not de-congeal oil in the sump, lines, cooler, filter, etc. Congealed oil in these areas will require considerable preheat.

An engine that has been superficially warmed, may start and appear to run satisfactorily, but can be damaged from lack of lubrication due to the congealed oil blocking proper oil flow through the engine. The amount of damage will vary and may not become evident for many hours. However, the engine may be severely damaged and may fail shortly following application of high power. Proper procedures require thorough application of preheat to all parts of the engine. Hot air must be applied directly to the oil sump and external oil lines as well as the

cylinders, air intake and oil cooler. Because excessively hot air can damage non-metallic components such as composite parts, seals, hoses, and drives belts, do not attempt to hasten the preheat process.

1. Ignition Switch OFF

• WARNING •

Use extreme caution when pulling the propeller through by hand. Make sure ignition switch is OFF, keys are out of ignition, and then act as if the engine will start. A loose or broken ground wire on either magneto could cause the engine to fire.

2. Propeller Hand TURN several rotations
3. External Power (If applicable) CONNECT
4. Brakes HOLD
5. Bat Master Switches ON (check voltage)
6. Mixture FULL RICH
7. Power lever FULL FORWARD
8. Fuel Pump PRIME, then BOOST

• Note •

Serials 0002 - 0278 before SB 22-73-01: In temperatures down to 20°F, hold Fuel Pump switch to PRIME for 60-120 seconds prior to starting.

Serials 0002 - 0278 after SB 22-73-01 and 0279 and subsequent: In temperatures down to 20°F, hold Fuel Pump switch to PRIME for 15 seconds prior to starting.

9. Propeller Area CLEAR
10. Power Lever OPEN ¼ INCH

(Continued on following page)

11. Ignition Switch..... START (Release after engine starts)

• Caution •

Limit cranking to intervals of 20 seconds with a 20 second cooling period between cranks. This will improve battery and contactor life

12. Power LeverRETARD (to maintain 1000 RPM)
13. Oil Pressure CHECK
14. Alt Master SwitchesON
15. Avionics Power SwitchON
16. Engine Parameters MONITOR
17. External Power (If applicable) DISCONNECT
18. Amp Meter/Indication CHECK
19. Strobe Lights.....ON

Hot Weather Operation

Avoid prolonged engine operation on the ground. Fuel BOOST must be ON for engine start and takeoff, and should be ON during climb for vapor suppression which could occur under hot ambient conditions or after extended idle.

Ground Operation of Air Conditioning System (Optional)

• Note •

To facilitate faster cabin cooling, prior to engine start leave the cabin doors open for a short time to allow hot air to escape cabin.

1. Control PanelSELECT Desired Mode and Temperature
2. Voltage MONITOR

• Note •

Decrease electrical load if battery discharge is noted.

3. Annunciator Lights CHECK
a. Verify ALT 1 caution light out and positive amps indication.
4. Engine Parameters CHECK

Noise Characteristics/Abatement

The certificated noise levels for the Cirrus Design SR22 established in accordance with FAR 36 Appendix G are:

Configuration	Actual	Maximum Allowable
Hartzel 3-blade Propeller PHC-J3YF-1RF/F7694	83.65 dB(A)	88.00 dB(A)
Hartzel 3-blade Propeller PHC-J3YF-1RF/F7693DF	84.81 dB(A)	88.00 dB(A)
McCaughey 3-blade Propeller D3A34C443/78CYA-0	83.15 dB(A)	88.00 dB(A)
MT 3-blade Propeller MTV-9-D/198-52	84.80 dB(A)	88.00 dB(A)

No determination has been made by the Federal Aviation Administration that the noise levels of this airplane are or should be acceptable or unacceptable for operation at, into, or out of, any airport. The above noise levels were established at 3400 pounds takeoff weight and 2700 RPM.

Recently, increased emphasis on improving environmental quality requires all pilots to minimize the effect of airplane noise on the public. The following suggested procedures minimize environmental noise when operating the SR22.

• Note •

Do not follow these noise abatement procedures where they conflict with Air Traffic Control clearances or instructions, weather considerations, or wherever they would reduce safety.

1. When operating VFR over noise-sensitive areas, such as outdoor events, parks, and recreational areas, fly not less than 2000 feet above the surface even though flight at a lower level may be allowed.
2. For departure from or approach to an airport, avoid prolonged flight at low altitude near noise-sensitive areas.

Fuel Conservation

Minimum fuel use at cruise will be achieved using the best economy power setting described under cruise.

Intentionally Left Blank

Section 5

Performance Data

Table of Contents

Introduction	5-3
Associated Conditions Affecting Performance	5-3
Demonstrated Operating Temperature	5-3
Airspeed Calibration	5-4
Normal Static Source	5-4
Airspeed Calibration	5-5
Alternate Static Source	5-5
Altitude Correction	5-6
Normal Static Source	5-6
Altitude Correction	5-7
Alternate Static Source	5-7
Temperature Conversion	5-8
Outside Air Temperature for ISA Condition	5-9
Stall Speeds	5-10
Wind Components	5-11
Takeoff Distance	5-12
Takeoff Distance	5-13
Takeoff Distance	5-14
Takeoff Climb Gradient	5-15
Takeoff Rate of Climb	5-16
Enroute Climb Gradient	5-17
Enroute Rate of Climb	5-18
Enroute Rate of Climb Vs Density Altitude	5-19
Time, Fuel and Distance to Climb	5-20
Cruise Performance	5-21
Range / Endurance Profile	5-24
Range / Endurance Profile	5-25
Range / Endurance Profile	5-26
Balked Landing Climb Gradient	5-27
Balked Landing Rate of Climb	5-28
Landing Distance	5-29
Landing Distance	5-30

Intentionally Left Blank

Introduction

Performance data in this section are presented for operational planning so that you will know what performance to expect from the airplane under various ambient and field conditions. Performance data are presented for takeoff, climb, and cruise (including range & endurance).

Associated Conditions Affecting Performance

Computed performance data in this section are based upon data derived from actual flight testing with the airplane and engine in good condition and using average piloting techniques. Unless specifically noted in the “Conditions” notes presented with each table, ambient conditions are for a standard day (*refer to Section 1*). Flap position as well as power setting technique is similarly noted with each table.

The charts in this section provide data for ambient temperatures from -20°C (-4°F) to 40°C (104°F). If ambient temperature is below the chart value, use the lowest temperature shown to compute performance. This will result in more conservative performance calculations. If ambient temperature is above the chart value, use extreme caution as performance degrades rapidly at higher temperatures.

All fuel flow data for cruise is based on the recommended lean mixture setting detailed in Section 4 – Normal Procedures.

Aircraft with optional Air Conditioning System; Brake Horsepower is reduced by approximately 6 BHP.

Demonstrated Operating Temperature

Satisfactory engine cooling has been demonstrated for this airplane with an outside air temperature 23°C above standard. The value given is not considered an operating limitation. Reference should be made to Section 2 for engine operating limitations.

Airspeed Calibration - Normal Static Source

Conditions:

- Power for level flight or maximum continuous, whichever is less.
- Note •
- Indicated airspeed values assume zero instrument error.

KIAS	KCAS		
	Flaps 0%	Flaps 50%	Flaps 100%
60			58
70		68	69
80	79	80	80
90	90	91	90
100	100	101	100
110	110	111	
120	121	121	
130	131		
140	142		
150	152		
160	162		
170	172		
180	183		
190	193		
200	203		

Figure 5-1

Airspeed Calibration - Alternate Static Source

Conditions:

- Power for level flight or maximum continuous, whichever is less.
- Heater, Defroster & Vents ON

• Note •

- Indicated airspeed values assume zero instrument error.

KIAS	KCAS		
	Flaps 0%	Flaps 50%	Flaps 100%
60			62
70		71	73
80	80	81	82
90	90	91	92
100	100	101	101
110	110	111	
120	120	121	
130	130		
140	140		
150	150		
160	160		
170	170		
180	180		
190	190		
200	199		

Figure 5-2

Altitude Correction

Normal Static Source: Standby Altimeter

Conditions:

- Power for level flight or maximum continuous, whichever is less.
- 3400 LB

• Note •

Add correction to desired altitude to obtain indicated altitude to fly.

Indicated airspeed values assume zero instrument error.

- KIAS: Knots Indicated Airspeed.

Flaps	Press Alt	CORRECTION TO BE ADDED - FEET									
		Normal Static Source - KIAS									
		60	70	80	90	100	120	140	160	180	200
0%	S.L		8	6	3	0	-9	-19	-31	-44	-56
	5000		10	7	4	0	-10	-23	-36	-51	-65
	10000		11	8	5	0	-12	-26	-42	-59	-76
	15000		13	10	5	0	-14	-31	-50	-70	-90
50%	S.L		14	3	-6	-12	-6				
	5000		17	4	-7	-14	-7				
	10000		19	4	-9	-17	-8				
100%	S.L	13	8	3	0	-1					
	5000	15	9	3	0	-1					
	10000	17	10	4	0	-2					

Figure 5-3

Altitude Correction

Alternate Static Source: Standby Altimeter

Conditions:

- Power for level flight or maximum continuous, whichever is less.
- Heater, Defroster, & Vents..... ON

• Note •

Add correction to desired altitude to obtain indicated altitude to fly.

Indicated airspeed values assume zero instrument error.

- KIAS: Knots Indicated Airspeed.

Flaps	Press Alt	CORRECTION TO BE ADDED - FEET									
		Normal Static Source - KIAS									
		60	70	80	90	100	120	140	160	180	200
0%	S.L		1	0	-1	-1	-3	-3	-1	4	13
	5000		2	0	-1	-2	-3	-3	-1	5	15
	10000		2	1	-1	-2	-4	-4	-1	6	18
	15000		2	1	-1	-2	-4	-4	-1	7	21
50%	S.L		-7	-6	-5	-5	-9				
	5000		-8	-7	-6	-6	-10				
	10000		-9	-8	-7	-7	-12				
100%	S.L	-14	-17	-18	-16	-10					
	5000	-16	-20	-21	-19	-12					
	10000	-18	-23	-25	-22	-14					

Figure 5-4

Temperature Conversion

To convert from Celsius (°C) to Fahrenheit (°F), find, in the shaded columns, the number representing the temperature value (°C) to be converted. The equivalent Fahrenheit temperature is read to the right.

► EXAMPLE: 38°C = 100°F.

To convert from Fahrenheit (°F) to Celsius (°C), find in the shaded columns area, the number representing the temperature value (°F) to be converted. The equivalent Celsius temperature is read to the left.

► EXAMPLE: 38°F = 3°C.

Temp to Convert °C or °F			Temp to Convert °C or °F			Temp to Convert °C or °F		
°C	◀ ▶	°F	°C	◀ ▶	°F	°C	◀ ▶	°F
-50	-58	-72	-17	2	36	17	62	144
-49	-56	-69	-16	4	39	18	64	147
-48	-54	-65	-14	6	43	19	66	151
-47	-52	-62	-13	8	46	20	68	154
-46	-50	-58	-12	10	50	21	70	158
-44	-48	-54	-11	12	54	22	72	162
-43	-46	-51	-10	14	57	23	74	165
-42	-44	-47	-9	16	61	24	76	169
-41	-42	-44	-8	18	64	26	78	172
-40	-40	-40	-7	20	68	27	80	176
-39	-38	-36	-6	22	72	28	82	180
-38	-36	-33	-4	24	75	29	84	183
-37	-34	-29	-3	26	79	30	86	187
-36	-32	-26	-2	28	82	31	88	190
-34	-30	-22	-1	30	86	32	90	194
-33	-28	-18	0	32	90	33	92	198
-32	-26	-15	1	34	93	34	94	201
-31	-24	-11	2	36	97	36	96	205
-30	-22	-8	3	38	100	37	98	208
-29	-20	-4	4	40	104	38	100	212
-28	-18	0	6	42	108	39	102	216
-27	-16	3	7	44	111	40	104	219
-26	-14	7	8	46	115	41	106	223
-24	-12	10	9	48	118	42	108	226
-23	-10	14	10	50	122	43	110	230
-22	-8	18	11	52	126	44	112	234
-21	-6	21	12	54	129	46	114	237
-20	-4	25	13	56	133	47	116	241
-19	-2	28	14	58	136	48	118	244
-18	0	32	16	60	140	49	120	248

Figure 5-5

Outside Air Temperature for ISA Condition

Press Alt Feet	ISA-40°C		ISA-20°C		ISA		ISA+10°C		ISA+20°C	
	°C	°F	°C	°F	°C	°F	°C	°F	°C	°F
SL	-25	-13	-5	23	15	59	25	77	35	95
1000	-27	-18	-7	18	13	54	23	72	33	90
2000	-29	-20	-9	16	11	52	21	70	31	88
3000	-31	-24	-11	12	9	48	19	66	29	84
4000	-33	-27	-13	9	7	45	17	63	27	81
5000	-35	-31	-15	5	5	41	15	59	25	77
6000	-37	-34	-17	2	3	38	13	56	23	74
7000	-39	-38	-19	-2	1	34	11	52	21	70
8000	-41	-42	-21	-6	-1	30	10	48	20	66
9000	-43	-45	-23	-9	-3	27	7	45	17	63
10000	-45	-49	-25	-13	-5	23	5	41	15	59
11000	-47	-52	-27	-16	-7	20	3	38	13	56
12000	-49	-56	-29	-20	-9	16	1	34	11	52
13000	-51	-59	-31	-23	-11	13	-1	31	9	49
14000	-53	-63	-33	-27	-13	9	-3	27	7	45
15000	-55	-67	-35	-31	-15	6	-5	23	5	41
16000	-57	-71	-37	-34	-17	2	-7	20	3	38
17000	-59	-75	-39	-38	-19	-2	-9	16	1	34
17500	-60	-76	-40	-40	-20	-3	-10	14	0	32

Figure 5-6

Stall Speeds

Conditions:

- Weight 3400 LB
- CG Noted
- Power..... Idle
- Bank Angle Noted

• Note •

Altitude loss during wings level stall may be 250 feet or more.

- KIAS values may not be accurate at stall.

Weight LB	Bank Angle Deg	STALL SPEEDS					
		Flaps 0%Full Up		Flaps 50%		Flaps 100%Full Down	
		KIAS	KCAS	KIAS	KCAS	KIAS	KCAS
3400 Most FWD C.G.	0	70	69	67	64	59	59
	15	71	70	68	65	62	60
	30	75	74	72	69	66	64
	45	84	82	80	76	73	70
	60	99	97	95	90	87	84
3400 Most AFT C.G.	0	68	67	66	62	61	59
	15	69	68	67	63	62	60
	30	73	72	71	67	65	63
	45	81	79	78	74	72	70
	60	96	94	93	88	86	83

Figure 5-7

Wind Components

Example:

- Runway Heading 10°
- Wind Direction 60°
- Wind Velocity 15 Knots

• Note •

The max demonstrated crosswind is 20 knots. Value not considered limiting.

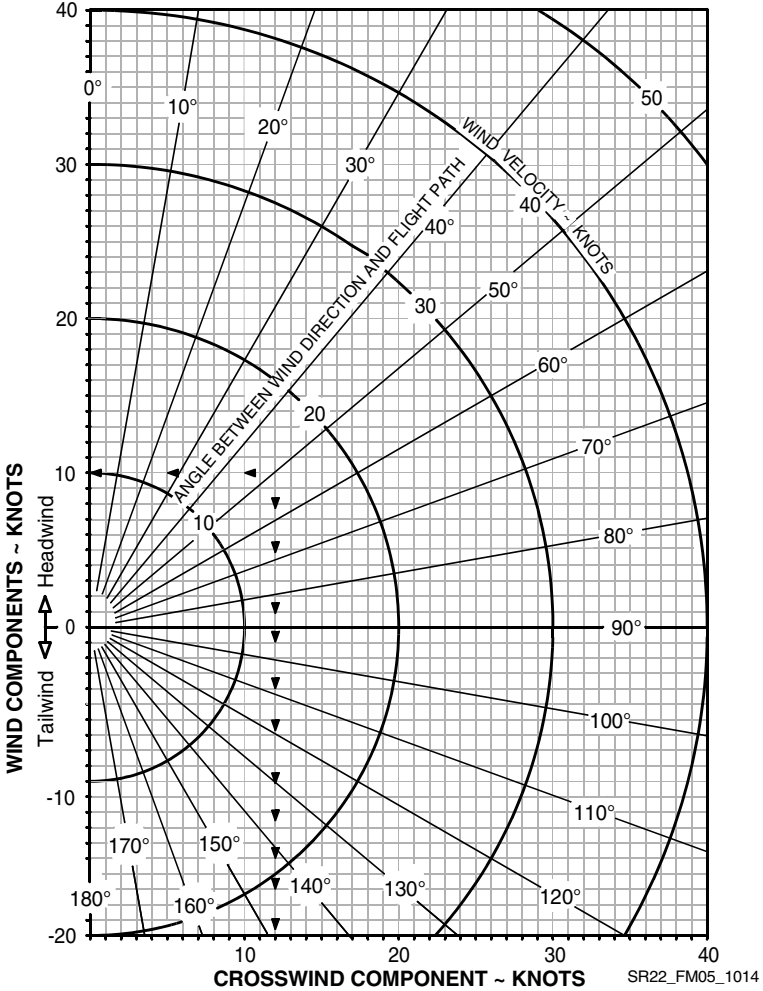

Figure 5-8

Takeoff Distance

Conditions:

- Winds.....Zero
- Runway.....Dry, Level, Paved
- Flaps.....50%
- Air Conditioner.....OFF
- Power:
 - Throttle.....Full Open
 - Mixture.....Set per Placard
Set prior to brake release for short field takeoff.

The following factors are to be applied to the computed takeoff distance for the noted condition:

- Headwind - Subtract 10% from computed distance for each 12 knots headwind.
- Tailwind - Add 10% for each 2 knots tailwind up to 10 knots.
- Grass Runway, Dry - Add 20% to ground roll distance.
- Grass Runway, Wet - Add 30% to ground roll distance.
- Sloped Runway - Increase table distances by 22% of the ground roll distance at Sea Level, 30% of the ground roll distance at 5000 ft, 43% of the ground roll distance at 10,000 ft for each 1% of upslope. Decrease table distances by 7% of the ground roll distance at Sea Level, 10% of the ground roll distance at 5000 ft, and 14% of the ground roll distance at 10,000 ft for each 1% of downslope.

• Caution •

The above corrections for runway slope are required to be included herein. These corrections should be used with caution since published runway slope data is usually the net slope from one end of the runway to the other. Many runways will have portions of their length at greater or lesser slopes than the published slope, lengthening (or shortening) takeoff ground roll estimated from the table.

- If brakes are not held while applying power, distances apply from point where full throttle and mixture setting is complete.
- For operation in outside air temperatures colder than this table provides, use coldest data shown.
- For operation in outside air temperatures warmer than this table provides, use extreme caution.
- Aircraft with optional Air Conditioning System; Add 100 feet to ground roll distance and 150 feet to distance over 50' obstacle if Air Conditioner is ON during takeoff.

Takeoff Distance - 3400 LB

Weight: 3400 LB
Speed at Liftoff: 73 KIAS
Speed over 50 Ft. Obstacle: 78 KIAS
Flaps: 50%
Power: Takeoff
Runway: Dry, Paved, Level

Headwind: Subtract 10% for each 12 knots headwind.
Tailwind: Add 10% for each 2 knots tailwind up to 10 knots.
Runway Slope: Reference Notes.
Dry Grass: Add 20% to Ground Roll.
Wet Grass: Add 30% to Ground Roll.
Air Conditioner: Add 100' to ground roll and 150' to distance over 50' obstacle if Air Conditioner if ON during takeoff.

PRESS ALT FT	DISTANCE FT	TEMPERATURE ~°C					ISA
		0	10	20	30	40	
SL	Grnd Roll	917	990	1067	1146	1229	1028
	50 ft	1432	1539	1650	1764	1883	1594
1000	Grnd Roll	1011	1092	1176	1264	1355	1117
	50 ft	1574	1691	1813	1939	2069	1728
2000	Grnd Roll	1116	1206	1299	1395	1496	1215
	50 ft	1732	1861	1995	2133	2276	1874
3000	Grnd Roll	1234	1332	1435	1542	1653	1323
	50 ft	1907	2049	2196	2349	2507	2035
4000	Grnd Roll	1365	1474	1588	1706	1829	1441
	50 ft	2102	2259	2422	2590	2764	2212
5000	Grnd Roll	1512	1633	1758	1889	2025	1572
	50 ft	2320	2493	2673	2858	3051	2407
6000	Grnd Roll	1676	1810	1950	2095	2245	1717
	50 ft	2564	2755	2953	3159	3371	2622
7000	Grnd Roll	1861	2009	2164	2325	2492	1877
	50 ft	2837	3048	3267	3494	3729	2859
8000	Grnd Roll	2068	2233	2405	2584	2770	2054
	50 ft	3142	3376	3619	3871	4131	3122
9000	Grnd Roll	2302	2485	2677	2875	3082	2250
	50 ft	3485	3744	4014	4293	4581	3412
10000	Grnd Roll	2564	2769	2982	3204	3434	2468
	50 ft	3870	4158	4457	4767	5088	3733

Figure 5-9
Sheet 1 of 2

Takeoff Distance - 2900 LB

<p>Weight: 2900 LB Speed at Liftoff: 70 KIAS Speed over 50 Ft. Obstacle: 74 KIAS Flaps: 50% Power: Takeoff Runway: Dry, Paved, Level</p>	<p>Headwind: Subtract 10% for each 12 knots headwind. Tailwind: Add 10% for each 2 knots tailwind up to 10 knots. Runway Slope: Reference Notes. Dry Grass: Add 20% to Ground Roll. Wet Grass: Add 30% to Ground Roll. Air Conditioner: Add 100' to ground roll and 150' to distance over 50' obstacle if Air Conditioner if ON during takeoff.</p>
---	--

PRESS ALT FT	DISTANCE FT	TEMPERATURE ~°C					ISA
		0	10	20	30	40	
SL	Grnd Roll	610	659	710	763	818	684
	50 ft	971	1043	1118	1195	1275	1080
1000	Grnd Roll	673	727	783	841	902	743
	50 ft	1066	1146	1228	1313	1401	1170
2000	Grnd Roll	743	802	864	929	995	809
	50 ft	1173	1260	1351	1444	1541	1269
3000	Grnd Roll	821	887	955	1026	1100	880
	50 ft	1292	1388	1487	1590	1697	1378
4000	Grnd Roll	908	981	1057	1135	1217	959
	50 ft	1424	1530	1639	1753	1871	1498
5000	Grnd Roll	1006	1086	1170	1257	1348	1046
	50 ft	1571	1688	1809	1935	2065	1630
6000	Grnd Roll	1116	1205	1298	1394	1494	1143
	50 ft	1736	1865	1999	2138	2281	1775
7000	Grnd Roll	1238	1337	1440	1547	1659	1249
	50 ft	1920	2063	2211	2365	2523	1936
8000	Grnd Roll	1376	1486	1601	1720	1843	1367
	50 ft	2127	2285	2449	2619	2795	2113
9000	Grnd Roll	1532	1654	1781	1914	2051	1498
	50 ft	2359	2534	2716	2904	3099	2309
10000	Grnd Roll	1707	1843	1985	2132	2285	1643
	50 ft	2619	2814	3016	3225	3441	2527

Figure 5-9
Sheet 2 of 2

Takeoff Climb Gradient

Conditions:

- Power Full Throttle
- Mixture Set per Placard
- Flaps 50%
- Airspeed Best Rate of Climb

• Note •

Climb Gradients shown are the gain in altitude for the horizontal distance traversed expressed as Feet per Nautical Mile.

Fuel flow must be set to the placarded limit for all takeoffs and climbs.

Cruise climbs or short duration climbs are permissible at best power as long as altitudes and temperatures remain within those specified in the table.

For operation in air colder than this table provides, use coldest data shown.

For operation in air warmer than this table provides, use extreme caution.

Weight LB	Press Altitude FT	Climb Speed KIAS	CLIMB GRADIENT ~ Feet per Nautical Mile				
			Temperature ~°C				
			-20	0	20	40	ISA
3400	SL	91	939	896	853	811	864
	2000	90	834	793	752	711	770
	4000	89	734	694	654	615	680
	6000	88	638	600	561	524	594
	8000	88	546	509	472	436	510
	10000	87	458	422	387	353	431
2900	SL	91	1172	1122	1070	1019	1083
	2000	90	1049	1000	950	902	972
	4000	89	931	884	836	790	867
	6000	88	818	773	727	683	766
	8000	88	711	667	623	581	669
	10000	87	608	566	524	484	576

Figure 5-10

Takeoff Rate of Climb

Conditions:

- Power..... Full Throttle
- Mixture..... Set per Placard
- Flaps..... 50%
- Airspeed Best Rate of Climb

• Note •

Rate-of-Climb values shown are change in altitude for unit time expended expressed in Feet per Minute.

Fuel flow must be set to the placarded limit for all takeoffs and climbs.

Cruise climbs or short duration climbs are permissible at best power as long as altitudes and temperatures remain within those specified in the table.

For operation in air colder than this table provides, use coldest data shown.

For operation in air warmer than this table provides, use extreme caution.

Aircraft with optional Air Conditioning System - Maximum rate of climb performance is reduced by approximately 50 feet per minute. For maximum climb performance the air-conditioner should be off.

Weight LB	Press Altitude FT	Climb Speed KIAS	RATE OF CLIMB ~ Feet per Minute				
			Temperature ~°C				
			-20	0	20	40	ISA
3400	SL	91	1326	1317	1300	1277	1304
	2000	90	1214	1200	1179	1153	1189
	4000	89	1100	1082	1057	1028	1074
	6000	88	985	962	934	901	958
	8000	88	869	842	809	774	843
	10000	87	851	719	683	644	727
2900	SL	91	1646	1638	1621	1598	1626
	2000	90	1518	1505	1484	1457	1494
	4000	89	1389	1371	1346	1316	1363
	6000	88	1259	1236	1207	1172	1232
	8000	88	1128	1100	1066	1028	1101
	10000	87	995	962	924	883	971

Figure 5-11

Enroute Climb Gradient

Conditions:

- Power Full Throttle
- Mixture Full Rich
- Flaps 0% (UP)
- Airspeed Best Rate of Climb

• Note •

Climb Gradients shown are the gain in altitude for the horizontal distance traversed expressed as Feet per Nautical Mile.

Fuel flow must be set to the placarded limit for all takeoffs and climbs.

Cruise climbs or short duration climbs are permissible at best power as long as altitudes and temperatures remain within those specified in the table.

For operation in air colder than this table provides, use coldest data shown.

For operation in air warmer than this table provides, use extreme caution.

Weight LB	Press Altitude FT	Climb Speed KIAS	CLIMB GRADIENT - Feet per Nautical Mile				
			Temperature ~°C				
			-20	0	20	40	ISA
3400	SL	101	911	867	823	781	834
	2000	100	813	771	729	689	748
	4000	99	720	679	639	600	665
	6000	98	630	590	552	515	584
	8000	97	544	505	468	433	507
	10000	96	461	424	388	354	433
	12000	95	381	346	312	279	361
	14000	94	304	271	238	207	292
2900	SL	101	1130	1078	1026	975	1039
	2000	100	1015	965	915	867	937
	4000	99	905	857	809	763	840
	6000	98	800	753	708	664	746
	8000	97	699	654	611	569	656
	10000	96	603	560	518	478	570
	12000	95	610	469	429	391	487
	14000	94	422	382	344	308	407
16000	93	337	299	263	229	331	

Figure 5-12

Enroute Rate of Climb

Conditions:

- Power..... Full Throttle
- Mixture..... As Required
- Flaps.....0% (UP)
- Airspeed Best Rate of Climb

• Note •

Rate-of-Climb values shown are change in altitude in feet per unit time expressed in Feet per Minute.

Fuel flow must be set to the placarded limit for all takeoffs and climbs.

Cruise climbs or short duration climbs are permissible at best power as long as altitudes and temperatures remain within those specified in the table.

For operation in air colder than this table provides, use coldest data shown.

For operation in air warmer than this table provides, use extreme caution.

Aircraft with optional Air Conditioning System; Maximum rate of climb performance is reduced by approximately 50 feet per minute if system is ON. For maximum climb performance the air-conditioner should be off.

Weight	Press Altitude	Climb Speed	RATE OF CLIMB ~ Feet per Minute				
			Temperature ~ °C				
LB	FT	KIAS	-20	0	20	40	ISA
3400	SL	101	1428	1414	1392	1366	1398
	2000	100	1311	1292	1267	1238	1279
	4000	99	1193	1170	1141	1108	1160
	6000	98	1074	1046	1013	977	1041
	8000	97	953	921	884	845	922
	10000	96	830	794	754	712	803
	12000	95	706	666	623	577	684
	14000	94	581	537	490	441	565
2900	SL	101	1761	1748	1726	1698	1732
	2000	100	1629	1610	1584	1552	1596
	4000	99	1494	1471	1441	1405	1461
	6000	98	1359	1331	1296	1257	1326
	8000	97	1222	1189	1151	1108	1191
	10000	95	1084	1046	1004	958	1056
	12000	95	945	902	855	806	921
	14000	93	804	757	706	653	787
	16000	92	662	610	556	499	653

Figure 5-13

Enroute Rate of Climb Vs Density Altitude

Conditions:

- Power Full Throttle
- Mixture Per Schedule - Section 4, Max Power Fuel Flow
- Flaps 0% (UP)
- Airspeed Best Rate of Climb

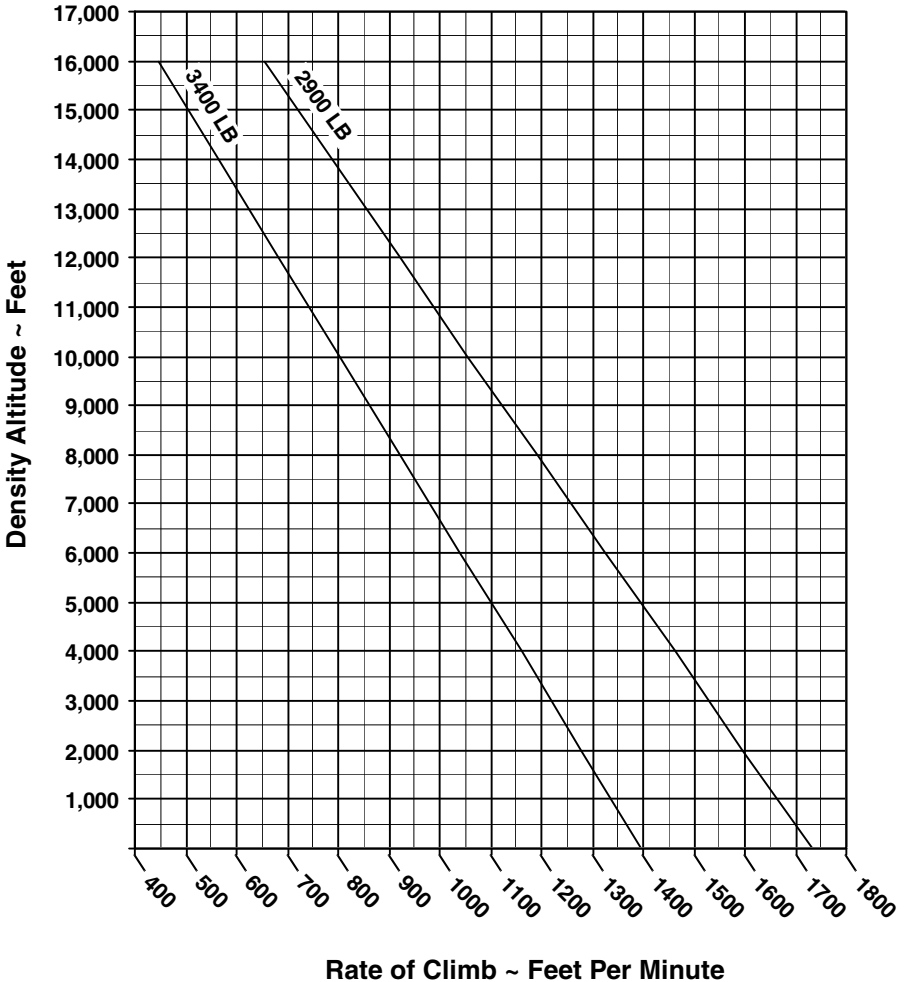

Figure 5-14

Time, Fuel and Distance to Climb

Conditions:

- Power..... Full Throttle
- Mixture..... Per Schedule, Section 4
- Fuel Density.....6.0 LB/GAL
- Weight3400 LB
- Winds.....Zero
- Climb AirspeedNoted

• Note •

Taxi Fuel - Add 1.5 gallon for start, taxi, and takeoff.

Temperature - Add 10% to computed values for each 10° C above standard.

Fuel flow must be set to the placarded limit for all takeoffs and climbs.

Cruise climbs or short duration climbs are permissible at best power as long as altitudes and temperatures remain within those specified in the table.

Press Alt	OAT (ISA)	Climb Speed	Rate Of Climb	TIME, FUEL, DISTANCE ~ From Sea Level		
				Time Minutes	Fuel U.S. Gal	Distance NM
FT	°C	KIAS	FPM			
SL	15	101	1398	0.0	0.0	0.0
1000	13	100	1339	0.7	0.3	1.0
2000	11	100	1279	1.5	0.7	2.5
3000	9	99	1220	2.5	1.0	4.0
4000	7	99	1160	3.0	1.3	5.5
5000	5	97	1101	4.0	1.7	7.0
6000	3	98	1041	5.0	2.0	8.5
7000	1	96	982	6.0	2.4	10.5
8000	-1	97	922	7.0	2.7	12.0
9000	-3	95	863	8.0	3.1	14.5
10000	-5	95	803	9.5	3.5	16.5
11000	-7	94	744	10.5	3.9	19.0
12000	-9	95	684	12.0	4.4	21.5
13000	-11	93	625	13.5	4.8	24.5
14000	-13	93	565	15.0	5.3	28.0
15000	-15	92	506	17.0	5.8	31.5
16000	-17	92	446	19.0	6.4	35.5
17000	-19	91	387	21.5	7.1	40.0
17500	-20	91	357	24.0	7.8	45.5

Figure 5-15

Cruise Performance

Conditions:

- Cruise Weight..... 2900 LB
- Winds Zero
- Shaded Cells: Cruise Pwr above 85% not recommended.

• Note •

Subtract 10 KTAS if nose wheel pant and fairing removed. Lower KTAS by 10% if nose and main wheel pants & fairings are removed.

Aircraft with optional Air Conditioning System - Cruise performance is reduced by 2 knots. For maximum performance, the air-conditioner should be off.

Press Alt	ISA - 30°C			ISA			ISA + 30°C				
	RPM	MAP	PWR	KTAS	GPH	PWR	KTAS	GPH	PWR	KTAS	GPH
2000	2700	27.4	103%	186	24.6	98%	186	23.3	93%	181	22.0
	2600	27.4	99%	183	23.5	94%	183	22.2	89%	178	21.5
	2500	27.4	93%	179	22.1	88%	179	20.9	84%	174	20.8
	2500	26.4	89%	176	21.1	84%	176	19.9	80%	171	20.2
	2500	25.4	84%	173	20.0	80%	173	19.0	76%	168	19.5
	2500	24.4	80%	170	19.0	76%	170	18.0	72%	165	18.8
	2500	23.4	76%	167	18.0	72%	167	17.0	68%	162	18.1
4000	2700	25.4	96%	185	22.9	91%	185	21.6	87%	180	20.8
	2600	25.4	92%	182	21.9	87%	182	20.7	83%	177	20.6
	2500	25.4	87%	178	20.6	82%	178	19.5	78%	173	19.9
	2500	24.4	82%	175	19.5	78%	175	18.5	74%	170	19.2
	2500	23.4	78%	172	18.5	74%	172	17.5	70%	167	18.5
	2500	22.4	73%	169	17.4	69%	169	16.5	66%	163	17.7
	2500	21.4	69%	165	16.4	65%	165	15.5	62%	159	16.9
6000	2700	23.5	89%	184	21.2	85%	184	20.1	81%	179	19.6
	2600	23.5	85%	181	20.3	81%	181	19.2	77%	176	19.1
	2500	23.5	80%	177	19.1	76%	177	18.1	72%	172	18.3
	2500	22.5	76%	174	18.1	72%	174	17.1	68%	169	17.6
	2500	21.5	72%	170	17.0	68%	170	16.1	64%	165	16.9
	2500	20.5	67%	166	15.9	64%	166	15.1	60%	161	16.1
	2500	19.5	63%	162	14.9	59%	162	14.1	56%	157	15.3

Figure 5-16
Sheet 1 of 2

Press Alt			ISA - 30°C			ISA			ISA + 30°C		
	RPM	MAP	PWR	KTAS	GPH	PWR	KTAS	GPH	PWR	KTAS	GPH
8000	2700	21.7	83%	183	19.7	78%	183	18.6	75%	178	17.7
	2600	21.7	79%	180	18.8	75%	180	17.8	71%	175	17.0
	2500	21.7	75%	176	17.7	71%	176	16.8	67%	171	16.0
	2500	20.7	70%	172	16.7	66%	172	15.8	63%	167	15.0
	2500	19.7	66%	168	15.6	62%	168	14.8	59%	163	14.0
	2500	18.7	61%	163	14.5	58%	163	13.8	55%	158	13.1
	2500	17.7	57%	159	13.5	54%	159	12.8	51%	153	12.1
10000	2700	20.0	77%	182	18.2	73%	182	17.3	69%	176	16.4
	2600	20.0	71%	177	17.0	68%	177	16.1	64%	172	15.3
	2500	20.0	67%	173	16.0	64%	173	15.1	61%	167	14.4
	2500	19.0	63%	168	14.9	59%	168	14.1	56%	163	13.4
	2500	18.0	58%	163	13.8	55%	163	13.1	52%	158	12.5
	2500	17.0	54%	158	12.8	51%	158	12.1	48%	153	11.5
12000	2700	18.5	71%	180	16.9	67%	180	16.0	64%	175	15.2
	2600	18.5	68%	177	16.2	64%	177	15.3	61%	172	14.5
	2500	18.5	64%	173	15.2	60%	173	14.4	58%	167	13.7
	2500	17.5	59%	168	14.1	56%	168	13.4	53%	162	12.7
	2500	16.5	55%	162	13.0	52%	162	12.3	49%	157	11.7
	2500	15.5	50%	156	12.0	48%	156	11.3	45%	151	10.8
14000	2700	17.1	66%	178	15.6	62%	178	14.8	59%	173	14.1
	2600	17.1	63%	175	14.9	60%	175	14.1	57%	170	13.5
	2500	17.1	59%	171	14.1	56%	171	13.3	53%	165	12.7
	2500	16.1	55%	165	13.0	52%	165	12.3	49%	159	11.7
	2500	15.1	50%	159	11.9	47%	159	11.2	45%	153	10.7
	2500	15.1	50%	159	11.9	47%	159	11.2	45%	153	10.7
16000	2700	15.8	61%	176	14.5	58%	176	13.7	55%	171	13.0
	2600	15.8	58%	173	13.8	55%	173	13.1	52%	167	12.5
	2500	15.8	55%	168	13.0	52%	168	12.3	49%	163	11.7
	2500	14.8	50%	162	11.9	47%	162	11.3	45%	156	10.7
17000	2700	15.2	59%	175	13.9	55%	175	13.2	53%	169	12.5
	2600	15.2	56%	171	13.3	53%	171	12.6	50%	166	12.0
	2500	15.2	53%	167	12.5	50%	167	11.9	47%	162	11.3
	2500	14.2	48%	160	11.4	45%	160	10.8	43%	155	10.3

Figure 5-16
Sheet 2 of 2

Range / Endurance Profile

Conditions:

- Weight 3400 LB
- Temperature Standard Day
- Winds..... Zero
- Mixture..... Best Economy
- Total Fuel..... 81 Gallons

• Note •

Fuel Remaining For Cruise is equal to 81.0 gallons usable, less climb fuel, less 9.8 gallons for 45 minutes IFR reserve fuel at 47% power (ISA @ 10,000 ft PA), less descent fuel, less fuel used prior to takeoff.

Range and endurance shown includes descent to final destination at approximately 178 KIAS and 500 fpm

Range is decreased by 5% if nose wheel pant and fairings removed.

Range is decreased by 15% if nose and main wheel pants and fairings removed.

Aircraft with optional air-conditioning system - Range is decreased by 1%. For maximum range the air-conditioner should be off.

75% POWER					Mixture: Best Power		
Press Alt	Climb Fuel	Fuel Remaining For Cruise	Airspeed	Fuel Flow	Endurance	Range	Specific Range
FT	Gal	Gal	KTAS	GPH	Hours	NM	Nm/Gal
SL	0.0	70.8	166	17.8	4.0	661	9.3
2000	0.7	69.0	170	17.8	3.9	670	9.6
4000	1.3	67.2	173	17.8	3.9	680	9.8
6000	2.0	65.3	177	17.8	3.9	689	10.0
8000	2.7	63.5	180	17.8	3.8	700	10.3

Range / Endurance Profile (Continued)

65% POWER						Mixture: Best Power	
Press Alt	Climb Fuel	Fuel Remaining For Cruise	Airspeed	Fuel Flow	Endurance	Range	Specific Range
FT	Gal	Gal	KTAS	GPH	Hours	NM	Nm/Gal
SL	0.0	70.8	158	15.4	4.6	725	10.3
2000	0.7	69.0	161	15.4	4.5	735	10.5
4000	1.3	67.2	165	15.4	4.5	745	10.7
6000	2.0	65.3	168	15.4	4.5	755	11.0
8000	2.7	63.5	171	15.4	4.4	765	11.2
10000	3.5	61.6	174	15.4	4.4	775	11.5
12000	4.4	59.8	178	15.4	4.3	785	11.8

55% POWER						Mixture: Best Power	
Press Alt	Climb Fuel	Fuel Remaining For Cruise	Airspeed	Fuel Flow	Endurance	Range	Specific Range
FT	Gal	Gal	KTAS	GPH	Hours	NM	Nm/Gal
SL	0.0	70.8	149	13.1	5.4	806	11.4
2000	0.7	69.0	152	13.1	5.4	815	11.6
4000	1.3	67.2	154	13.1	5.3	825	11.9
6000	2.0	65.3	157	13.1	5.3	835	12.2
8000	2.7	63.5	160	13.1	5.2	845	12.4
10000	3.5	61.6	163	13.1	5.1	856	12.7
12000	4.4	59.8	166	13.1	5.1	865	13.0
14000	5.3	57.8	169	13.1	5.0	875	13.4

55% POWER						Mixture: Best Economy	
Press Alt	Climb Fuel	Fuel Remaining For Cruise	Airspeed	Fuel Flow	Endurance	Range	Specific Range
FT	Gal	Gal	KTAS	GPH	Hours	NM	Nm/Gal
SL	0.0	70.8	149	11.3	6.2	930	13.1
2000	0.7	69.0	152	11.3	6.2	941	13.4
4000	1.3	67.2	154	11.3	6.1	951	13.7
6000	2.0	65.3	157	11.3	6.1	962	14.0
8000	2.7	63.5	160	11.3	6.0	974	14.3
10000	3.5	61.6	163	11.3	5.9	985	14.6
12000	4.4	59.8	166	11.3	5.9	995	15.0
14000	5.3	57.8	169	11.3	5.8	1006	15.4

Balked Landing Climb Gradient

Conditions:

- Power Full Throttle
- Mixture Set per Placard
- Flaps 100% (DN)
- Climb Airspeed..... V_{REF}

• Note •

Balked Landing Climb Gradients shown are the gain in altitude for the horizontal distance traversed expressed as Feet per Nautical Mile.

For operation in air colder than this table provides, use coldest data shown.

For operation in air warmer than this table provides, use extreme caution.

This chart is required data for certification. However, significantly better performance can be achieved by climbing at Best Rate of Climb speeds shown with flaps down or following the Go-Around / Balked Landing procedure in Section 4.

Weight LB	Press Alt FT	Climb Speed KIAS	CLIMB GRADIENT ~ Feet/Nautical Mile					Best Rate of Climb KIAS
			Temperature ~°C					
			-20	0	20	40	ISA	
3400	SL	77	834	835	823	803	827	80
	2000	77	750	744	728	704	736	80
	4000	77	666	654	633	604	648	79
	6000	77	581	564	537	504	560	78
	8000	77	496	472	440	402	473	77
	10000	77	409	379	341	296	387	77
2900	SL	77	1069	1070	1056	1032	1060	
	2000	77	969	962	942	914	953	
	4000	77	869	855	829	796	847	
	6000	77	789	747	716	677	743	
	8000	77	668	639	602	556	641	
	10000	77	565	529	484	432	639	

Figure 5-18

Balked Landing Rate of Climb

Conditions:

- Power..... Full Throttle
- Mixture..... Set per Placard
- Flaps..... 100% (DN)
- Climb Airspeed..... V_{REF}

• Note •

Balked Landing Rate of Climb values shown are the full flaps change in altitude for unit time expended expressed in Feet per Minute.

For operation in air colder than this table provides, use coldest data shown.

For operation in air warmer than this table provides, use extreme caution.

This chart is required data for certification. However, significantly better performance can be achieved by climbing at the Best Rate of Climb speeds shown with flaps down or following the Go-Around / Balked Landing procedure in Section 4.

Weight LB	Press Alt FT	Climb Speed KIAS	RATE OF CLIMB - Feet per Minute					Best Rate of Climb KIAS
			Temperature ~°C					
			-20	0	20	40	ISA	
3400	SL	77	996	1035	1057	1067	1053	80
	2000	77	930	959	972	971	966	80
	4000	77	858	876	878	867	878	79
	6000	77	779	784	775	752	784	78
	8000	77	691	683	660	623	684	77
	10000	77	593	571	532	478	578	77
2900	SL	77	1268	1318	1348	1363	1342	
	2000	77	1195	1233	1252	1255	1245	
	4000	77	1115	1140	1146	1137	1144	
	6000	77	1026	1037	1030	1007	1037	
	8000	77	927	923	900	861	923	
	10000	77	817	796	755	696	803	

Figure 5-19

Landing Distance

Conditions:

- Winds Zero
- Runway Dry, Level, Paved
- Flaps. 100%
- Power 3° Power Approach
to 50 FT obstacle, then reduce power passing the estimated 50 foot point and smoothly continue power reduction to reach idle just prior to touchdown.

• Note •

The following factors are to be applied to the computed landing distance for the noted condition:

- Headwind - Subtract 10% from table distances for each 13 knots headwind.
- Tailwind - Add 10% to table distances for each 2 knots tailwind up to 10 knots.
- Grass Runway, Dry - Add 20% to ground roll distance.
- Grass Runway, Wet - Add 60% to ground roll distance.
- Sloped Runway - Increase table distances by 27% of the ground roll distance for each 1% of downslope. Decrease table distances by 9% of the ground roll distance for each 1% of upslope.

• Caution •

The above corrections for runway slope are required to be included herein. These corrections should be used with caution since published runway slope data is usually the net slope from one end of the runway to the other. Many runways will have portions of their length at greater or lesser slopes than the published slope, lengthening (or shortening) landing ground roll estimated from the table.

- For operation in outside air temperatures colder than this table provides, use coldest data shown.
- For operation in outside air temperatures warmer than this table provides, use extreme caution.

Landing Distance

WEIGHT: 3400 LB Speed over 50 Ft Obstacle: 77 KIAS Flaps: 100% Power: Idle Runway: Dry, Paved, Level		Headwind: Subtract 10% for each 13 knots headwind. Tailwind: Add 10% for each 2 knots tailwind up to 10 knots. Runway Slope: Reference Notes Dry Grass: Add 20% to Ground Roll Wet Grass: Add 60% to Ground Roll					
PRESS ALT FT	DISTANCE FT	TEMPERATURE ~°C					ISA
		0	10	20	30	40	
SL	Grnd Roll	1082	1121	1161	1200	1240	1141
	Total	2262	2316	2372	2428	2485	2344
1000	Grnd Roll	1122	1163	1204	1245	1286	1175
	Total	2317	2374	2433	2492	2551	2391
2000	Grnd Roll	1163	1206	1248	1291	1334	1210
	Total	2375	2436	2497	2559	2621	2441
3000	Grnd Roll	1207	1251	1295	1339	1384	1247
	Total	2437	2501	2565	2630	2696	2493
4000	Grnd Roll	1252	1298	1344	1390	1436	1285
	Total	2503	2569	2637	2705	2774	2548
5000	Grnd Roll	1300	1348	1395	1443	1490	1324
	Total	2572	2642	2713	2785	2857	2605
6000	Grnd Roll	1350	1399	1449	1498	1547	1365
	Total	2645	2719	2794	2869	2945	2665
7000	Grnd Roll	1402	1453	1504	1556	1607	1408
	Total	2723	2800	2879	2958	3038	2728
8000	Grnd Roll	1456	1509	1563	1616	1669	1452
	Total	2805	2887	2969	3052	3136	2794
9000	Grnd Roll	1513	1569	1624	1679	1735	1497
	Total	2892	2978	3064	3152	3240	2863
10000	Grnd Roll	1573	1630	1688	1746	1803	1545
	Total	2984	3074	3165	3257	3350	2936

Figure 5-20

Section 6

Weight and Balance

Table of Contents

Introduction	6-3
Airplane Weighing Form	6-6
Airplane Weighing Procedures	6-7
Weight & Balance Record	6-10
Loading Instructions	6-12
Weight & Balance Loading Form	6-14
Loading Data	6-15
Moment Limits	6-16
Equipment List	6-17

Intentionally Left Blank

Introduction

This section describes the procedure for establishing the basic empty weight and moment of the airplane. Sample forms are provided for reference. Procedures for calculating the weight and moment for various operations are also provided. A comprehensive list of all equipment available for this airplane is included at the back of this section.

It should be noted that specific information regarding the weight, arm, moment, and installed equipment for this airplane as delivered from the factory can only be found in the plastic envelope carried in the back of this handbook.

It is the responsibility of the pilot to ensure that the airplane is loaded properly.

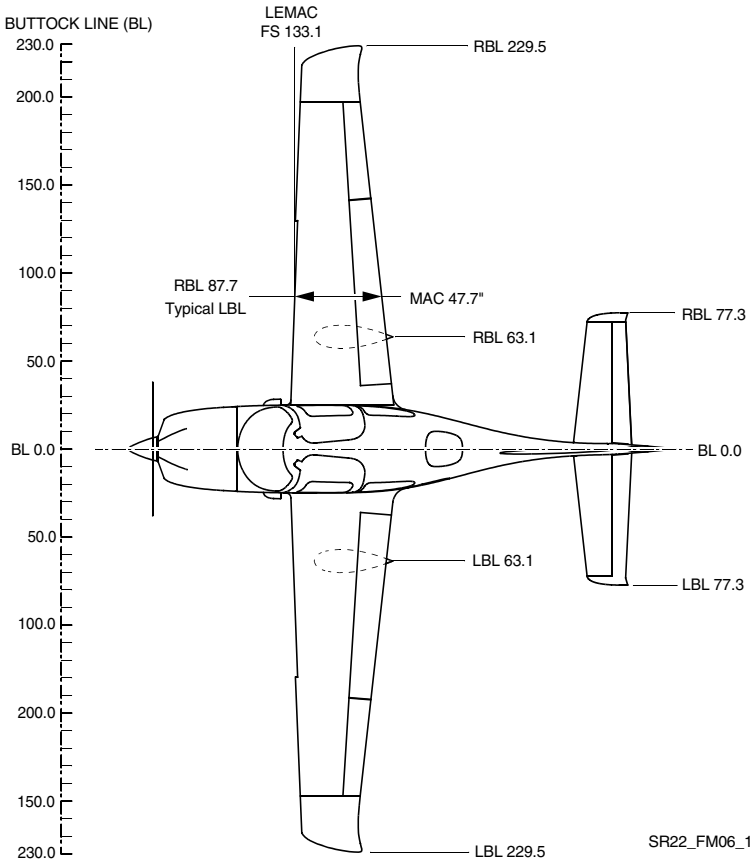
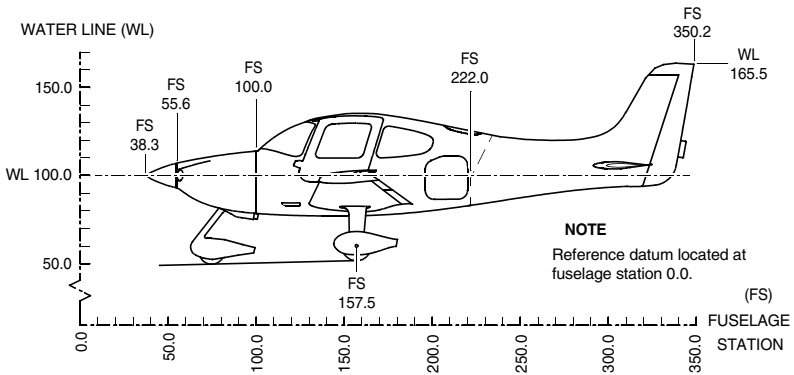

SR22_FM06_1439

Figure 6-1
Airplane Dimensional Data

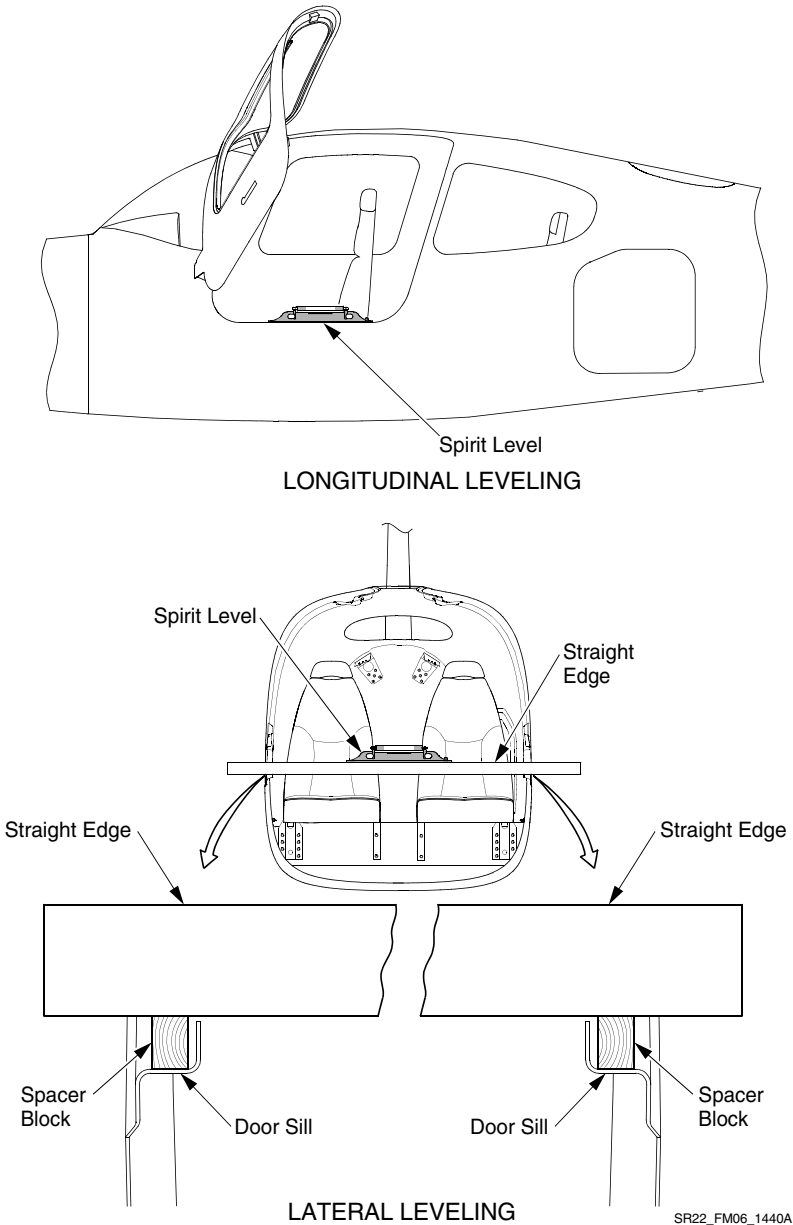

SR22_FM06_1440A

Figure 6-2
Airplane Leveling

Airplane Weighing Form

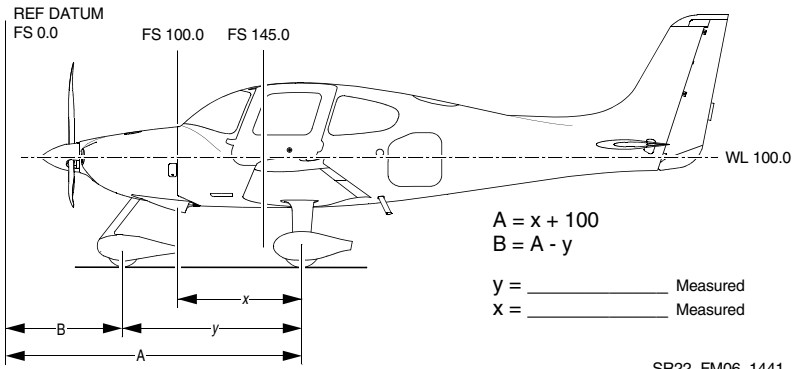

Weighing Point	Scale Reading	- Tare	= Net Weight	X Arm	= Moment
L Main				A=	
R Main				A=	
Nose				B=	
Total As Weighed				CG=	
CG = Total Moment / Total Weight					
<i>Space below provided for additions or subtractions to as weighed condition</i>					
Empty Weight				CG=	
Engine Oil (if oil drained) <i>15 lb at FS 78.4, moment = 1176</i>					
Unusable Fuel			18.0	154.9	2788
Basic Empty Weight				CG=	

Figure 6-3
Airplane Weighing Form

Airplane Weighing Procedures

A basic empty weight and center of gravity were established for this airplane when the airplane was weighed just prior to initial delivery. However, major modifications, loss of records, addition or relocation of equipment, accomplishment of service bulletins, and weight gain over time may require re-weighing to keep the basic empty weight and center of gravity current. The frequency of weighing is determined by the operator. All changes to the basic empty weight and center of gravity are the responsibility of the operator. *Refer to Section 8 for specific servicing procedures.*

1. Preparation:
 - a. Inflate tires to recommended operating pressures.
 - b. Service brake reservoir.
 - c. Drain fuel system.
 - d. Service engine oil.
 - e. Move crew seats to the most forward position.
 - f. Raise flaps to the fully retracted position.
 - g. Place all control surfaces in neutral position.
 - h. Verify equipment installation and location by comparison to equipment list.
2. Leveling (Figure 6-2):
 - a. Level longitudinally with a spirit level placed on the pilot door sill and laterally with of a spirit level placed across the door sills. Alternately, level airplane by sighting the forward and aft tool holes along waterline 95.9.
 - b. Place scales under each wheel (minimum scale capacity, 500 pounds nose, 1000 pounds each main).
 - c. Deflate the nose tire and/or shim underneath scales as required to properly center the bubble in the level.
3. Weighing (Figure 6-3):
 - a. With the airplane level, doors closed, and brakes released, record the weight shown on each scale. Deduct the tare, if any, from each reading.

4. Measuring (Figure 6-3):
 - a. Obtain measurement 'x' by measuring horizontally along the airplane center line (BL 0) from a line stretched between the main wheel centers to a plumb bob dropped from the forward side of the firewall (FS 100). Add 100 to this measurement to obtain left and right weighing point arm (dimension 'A'). Typically, dimension 'A' will be in the neighborhood of 157.5.
 - b. Obtain measurement 'y' by measuring horizontally and parallel to the airplane centerline (BL 0), from center of nosewheel axle, left side, to a plumb bob dropped from the line stretched between the main wheel centers. Repeat on right side and average the measurements. Subtract this measurement from dimension 'A' to obtain the nosewheel weighing point arm (dimension 'B').
5. Determine and record the moment for each of the main and nose gear weighing points using the following formula:

$$\text{Moment} = \text{Net Weight} \times \text{Arm}$$

6. Calculate and record the as-weighed weight and moment by totaling the appropriate columns.
7. Determine and record the as-weighed C.G. in inches aft of datum using the following formula:

$$\text{C.G.} = \text{Total Moment} / \text{Total Weight}$$

8. Add or subtract any items not included in the as-weighed condition to determine the empty condition. Application of the above C.G. formula will determine the C.G. for this condition.
9. Add the correction for engine oil (15 lb at FS 78.4), if the airplane was weighed with oil drained. Add the correction for unusable fuel (18.0 lb at FS 154.9) to determine the Basic Empty Weight and Moment. Calculate and record the Basic Empty Weight C.G. by applying the above C.G. formula.
10. Record the new weight and C.G. values on the Weight and Balance Record.

The above procedure determines the airplane Basic Empty Weight, moment, and center of gravity in inches aft of datum. C.G. can also be expressed in terms of its location as a percentage of the airplane Mean Aerodynamic Cord (MAC) using the following formula:

$$C.G. \% MAC = 100 \times (C.G. \text{ Inches} - LEMAC) / MAC$$

Where:

$$LEMAC = 133.1$$

$$MAC = 47.7$$

Weight & Balance Record

Use this form to maintain a continuous history of changes and modifications to airplane structure or equipment affecting weight and balance:

Serial Num:			Reg. Num:			Page of		
Date	Item No.		Description of Article or Modification	Weight Change Added (+) or Removed (-)			Running Basic Empty Weight	
	In	Out		WT LB	ARM IN.	MOM/ 1000	WT LB	MOM/ 1000
			As Delivered					

Figure 6-4
 Weight and Balance Record

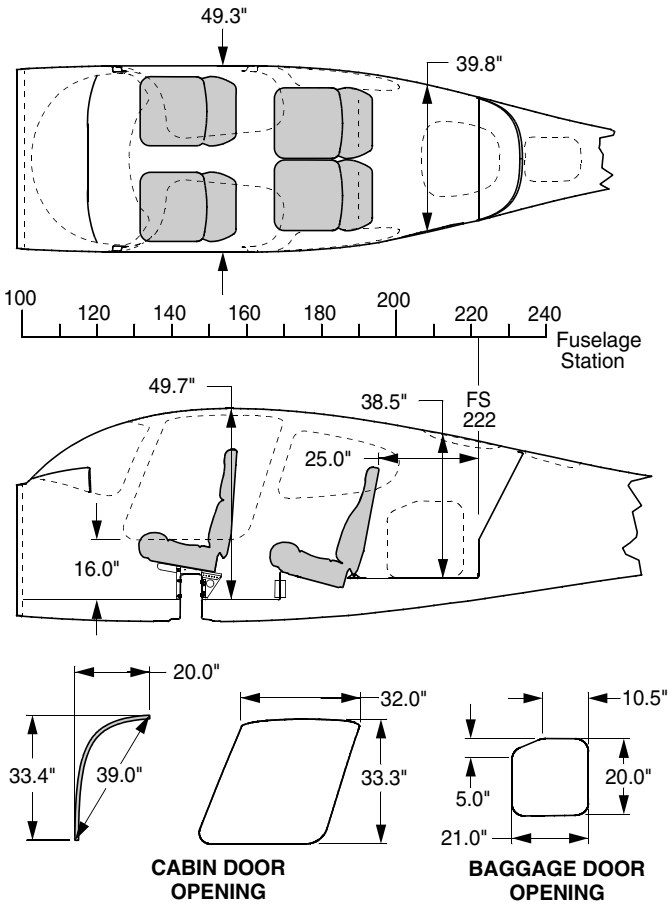

SR22_FM06_1019

Location	Length	Width	Height	Volume
Cabin	122"	49.3"	49.7	137 cu ft
Baggage Compartment	36"	39.8"	38.5"	32 cu ft

Figure 6-5
Airplane Interior Dimensions

Loading Instructions

It is the responsibility of the pilot to ensure that the airplane is properly loaded and operated within the prescribed weight and center of gravity limits. The following information enables the pilot to calculate the total weight and moment for the loading. The calculated moment is then compared to the Moment Limits chart or table for a determination of proper loading.

Airplane loading determinations are calculated using the Weight & Balance Loading Form (Figure 6-6), the Loading Data chart and table (Figure 6-7), and the Moment Limits chart and table (Figure 6-8).

1. **Basic Empty Weight** – Enter the current Basic Empty Weight and Moment from the Weight & Balance Record.
2. **Front Seat Occupants** – Enter the total weight and moment/1000 for the front seat occupants from the Loading Data.
3. **Rear Seat Occupants** – Enter the total weight and moment/1000 for the rear seat occupants from the Loading Data.
4. **Baggage** – Enter weight and moment for the baggage from the Loading Data.
 - If desired, subtotal the weights and moment/1000 from steps 1 through 4. This is the *Zero Fuel Condition*. It includes all useful load items excluding fuel.
5. **Fuel Loading** – Enter the weight and moment of usable fuel loaded on the airplane from the Loading Data.
 - Subtotal the weight and moment/1000. This is the *Ramp Condition* or the weight and moment of the aircraft before taxi.
6. **Fuel for start, taxi, and runup** – This value is pre-entered on the form. Normally, fuel used for start, taxi, and runup is approximately 9 pounds at an average moment/1000 of 1.394.
7. **Takeoff Condition** – Subtract the weight and moment/1000 for step 8 (start, taxi, and runup) from the Ramp Condition values (step 7) to determine the Takeoff Condition weight and moment/1000.
 - The total weight at takeoff must not exceed the maximum weight limit of 3400 pounds.

- The total moment/1000 must not be above the maximum or below the minimum moment/1000 for the *Takeoff Condition Weight* as determined from the Moment Limits chart or table. |

Weight & Balance Loading Form

Serial Num: _____ Date: _____

Reg. Num: _____ Initials: _____

Item	Description	Weight LB	Moment/ 1000
1.	Basic Empty Weight <i>Includes unusable fuel & full oil</i>		
2.	Front Seat Occupants <i>Pilot & Passenger (total)</i>		
3.	Rear Seat Occupants		
4.	Baggage Area <i>130 lb maximum</i>		
5.	Zero Fuel Condition Weight <i>Sub total item 1 thru 4</i>		
6.	Fuel Loading <i>81 Gallon @ 6.0 lb/gal. Maximum</i>		
7.	Ramp Condition Weight <i>Sub total item 5 and 6</i>		
8.	Fuel for start, taxi, and runup <i>Normally 9 lb at average moment of 1394.</i>	-	-
9.	Takeoff Condition Weight <i>Subtract item 8 from item 7</i>		

• Note •

The Takeoff Condition Weight must not exceed 3400 lb.

The Takeoff Condition Moment must be within the Minimum Moment to Maximum Moment range at the Takeoff Condition Weight. (Refer to Figure 6-8, Moment Limits).

Figure 6-6
Weight and Balance Loading Form

Loading Data

Use the following chart or table to determine the moment/1000 for fuel and payload items to complete the Loading Form.

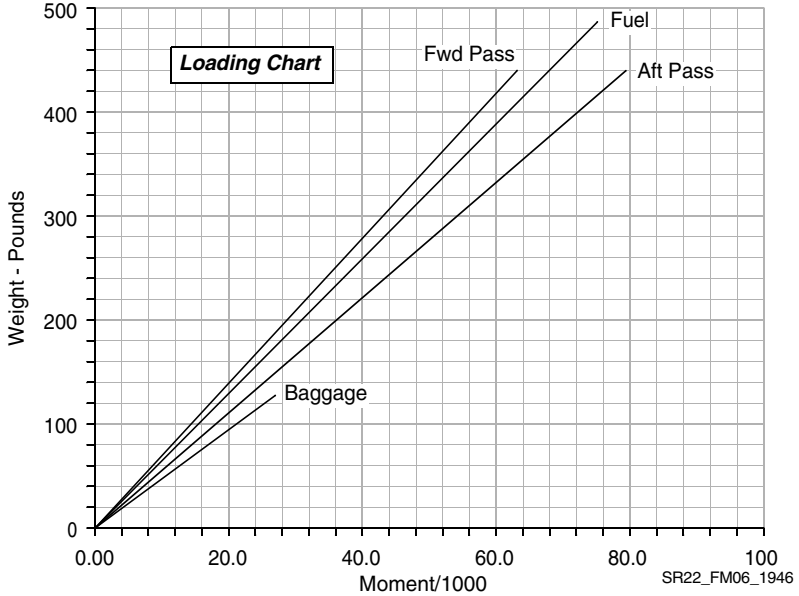

Weight LB	Fwd Pass FS 143.5	Aft Pass FS 180.0	Baggage FS 208.0	Fuel FS 154.9	Weight LB	Fwd Pass FS 143.5	Aft Pass FS 180.0	Fuel FS 154.9
20	2.87	3.60	4.16	3.10	260	37.31	46.80	40.27
40	5.74	7.20	8.32	6.20	280	40.18	50.40	43.37
60	8.61	10.80	12.48	9.29	300	43.05	54.00	46.47
80	11.48	14.40	16.64	12.39	320	45.92	57.60	49.57
100	14.35	18.00	20.80	15.49	340	48.79	61.20	52.67
120	17.22	21.60	24.96	18.59	360	51.66	64.80	55.76
140	20.09	25.20	(27.04)*	21.69	380	54.53	68.40	58.86
160	22.96	28.80		24.78	400	57.40	72.00	61.96
180	25.83	32.40		27.88	420	60.27	75.60	65.06
200	28.70	36.00		30.98	440	63.14	79.20	68.16
220	31.57	39.60		34.08	460			71.25
240	34.44	43.20		37.18	486**			75.28

*130 lb Maximum

**81 U.S. Gallons Usable

Figure 6-7
Loading Data

Moment Limits

Use the following chart or table to determine if the weight and moment from the completed Weight and Balance Loading Form are within limits.

• **Caution** •

Before landing, verify aircraft weight and moment do not fall in the Landing Limitation Zone.

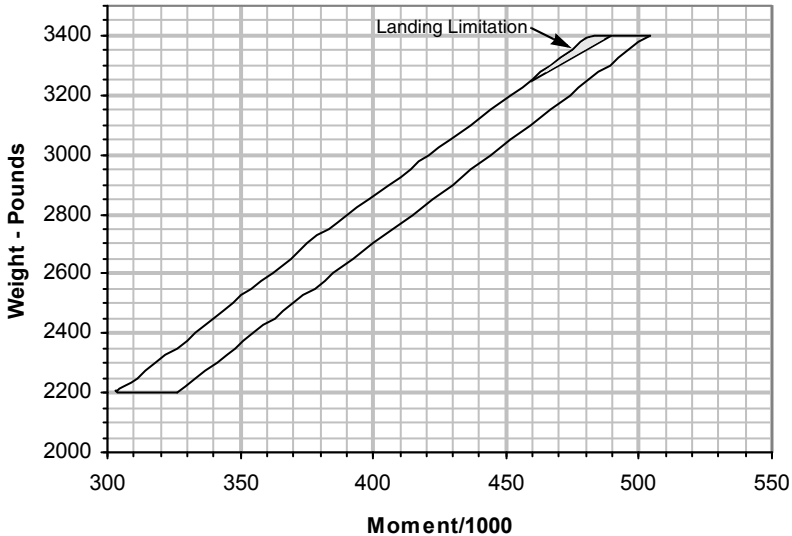

Weight LB	Moment/1000		Weight LB	Moment/1000	
	Minimum	Maximum		Minimum	Maximum
2200	304	326	2850	398	422
2250	311	333	2900	406	430
2300	318	341	2950	414	437
2350	326	348	3000	421	444
2400	333	355	3050	429	452
2450	340	363	3100	437	459
2500	347	370	3150	444	467
2550	354	378	3200	452	474
2600	362	385	3250	460	481
2650	369	392	3300	467	489
2700	375	400	3350	475	496
2750	383	407	3400	483	504
2800	390	415			

Figure 6-8
Moment Limits

Equipment List

This list will be determined after the final equipment has been installed in the aircraft.

Intentionally Left Blank

Section 7

Airplane and Systems Description

Table of Contents

Introduction	7-5
Airframe	7-6
Fuselage	7-6
Wings	7-6
Empennage	7-7
Flight Controls	7-8
Elevator System	7-8
Aileron System	7-10
Rudder System	7-12
Trim Systems	7-14
Pitch Trim Control System	7-14
Roll Trim Control System	7-14
Yaw Trim System	7-15
Flight Deck Arrangement	7-16
Instrument Panel	7-16
Center Console	7-17
Flight Instruments	7-21
Primary Flight Display - Serials 0435 and Subsequent	7-21
Attitude Indicator	7-26
Airspeed Indicator	7-26
Vertical Speed Indicator	7-27
Altimeter	7-27
Turn Coordinator	7-28
Course Deviation Indicator	7-28
Horizontal Situation Indicator	7-29
Magnetic Compass	7-31
Wing Flaps	7-32
Flap Control Switch	7-32
Landing Gear	7-34
Main Gear	7-34
Nose Gear	7-34
Airplane Cabin	7-34
Cabin Doors	7-34

Baggage Compartment..... 7-36

Seats..... 7-36

Windshield and Windows..... 7-37

Cabin Safety Equipment 7-38

Engine 7-41

 Engine Oil System 7-41

 Engine Cooling..... 7-42

 Engine Fuel Injection 7-42

 Engine Air Induction System..... 7-42

 Engine Fuel Ignition 7-42

 Engine Exhaust..... 7-43

 Engine Controls 7-43

 Alternate Air Control..... 7-44

 Engine Indicating 7-44

Propeller..... 7-53

Fuel System 7-54

 Fuel Selector Valve 7-56

 Fuel Quantity Indicator..... 7-57

 Fuel Flow Indication 7-60

 Fuel Caution Light..... 7-60

 Boost Pump Switch..... 7-61

Brake System..... 7-62

Electrical System..... 7-65

 Power Generation 7-65

 Power Distribution..... 7-66

 BAT & ALT Master Switches..... 7-68

 Avionics Power Switch..... 7-69

 Volts and Ampere Meter/Indication..... 7-69

 Ammeter Select Switch..... 7-71

 Low-Volts Warning Light 7-71

 ALT Fail Caution Lights..... 7-71

 Circuit Breakers and Fuses..... 7-72

 Ground Service Receptacle 7-73

 Convenience Outlet 7-73

Exterior Lighting 7-74

 Navigation Lights 7-74

 Strobe Light..... 7-74

 Landing Light 7-74

 Recognition Lights - Serials 1863 and subsequent..... 7-74

Interior Lighting	7-75
Instrument Lights	7-75
Panel Flood Lights	7-75
Reading Lights	7-75
Overhead Dome Light.....	7-75
Environmental System	7-76
Description and Operation	7-76
Pitot-Static System.....	7-90
Pitot Heat Switch	7-90
Pitot Heat Light	7-90
Alternate Static Source	7-92
Stall Warning System.....	7-92
Standard Avionics	7-93
Multi-Function Display	7-94
Autopilot.....	7-96
GPS Navigation	7-99
Communication (COM) Transceivers	7-101
Navigation (Nav) Receiver.....	7-102
Transponder	7-103
Audio System.....	7-103
Emergency Locator Transmitter	7-104
Hour Meter(s).....	7-106
Digital Clock.....	7-107
Cirrus Airplane Parachute System.....	7-109
System Description.....	7-109
Activation Handle.....	7-110
Deployment Characteristics.....	7-111

Intentionally Left Blank

Section 7 - Systems Description

Landing Gear

Main Gear

Serials w/ tubeless tire:

Each main gear wheel has a 15 x 6.00 x 6 tubeless tire installed.

Nose Gear

Serials w/ tubeless tire:

The tubeless nosewheel tire measures 5.00 x 5.

Brake System

Serials w/ Beringer Brake System:

The reservoir is serviced with MIL-PRF-87257 hydraulic fluid.

A temperature sensor is mounted to each brake assembly and provides measured brake temperatures to the avionics system for caution and warning annunciation.

Intentionally Left Blank

Section 7 - Systems Description

Airplane Cabin

Cabin Safety Equipment

Fire Extinguisher

A liquefied-gas-type fire extinguisher, containing either Halon 1211/1301 extinguishing agent (*Serials w/o gaged fire extinguisher*) or Halon 1211 (*Serials w/ gaged fire extinguisher*), is mounted on the forward inboard side of the pilot's seat base. The extinguisher is approved for use on class B (liquid, grease) and class C (electrical equipment) fires. A pin is installed through the discharge mechanism to prevent inadvertent discharge of extinguishing agent. *Serials w/o gaged fire extinguisher*: The fire extinguisher must be replaced after each use. *Serials w/ gaged fire extinguisher*: The fire extinguisher must be recharged or replaced after each use.

To operate the extinguisher:

1. Loosen retaining clamp and remove the extinguisher from its mounting bracket.
2. Hold the extinguisher upright and pull the pin.
3. Get back from the fire and aim nozzle at base of fire at the nearest edge.
4. Press red lever and sweep side to side.

• **WARNING** •

Halon gas used in the fire extinguisher can be toxic, especially in a closed area. After discharging fire extinguisher, ventilate cabin by opening air vents and unlatching door. Close vents and door after fumes clear.

The extinguisher must be inspected before each flight to assure that it is available, charged, and operable. The preflight inspection consists of ensuring that the nozzle is unobstructed, the pin has not been pulled, and the canister has not been damaged. *Serials w/o gaged fire extinguisher*: The unit should weigh approximately 1.5 lb (0.7 kg). For preflight, charge can be determined by 'hefting' the unit. *Serials w/ gaged fire extinguisher*: The unit should weigh approximately 2.5 lb (1.1 kg). For preflight, charge can be determined by verifying the gage pressure is in the operable (green) range, or by 'hefting' the unit.

Intentionally Left Blank

Introduction

This section provides a basic description and operation of the standard airplane and its systems. Optional equipment described within this section is identified as optional.

• Note •

Some optional equipment, primarily avionics, may not be described in this section. For description and operation of optional equipment not described in this section, *refer to Section 9, Supplements*

Airframe

Fuselage

The SR22 monocoque fuselage is constructed primarily of composite materials and is designed to be aerodynamically efficient. The cabin area is bounded on the forward side by the firewall at fuselage station 100, and on the rear by the aft baggage compartment bulkhead at fuselage station 222. Comfortable seating is provided for four adults. A composite roll cage within the fuselage structure provides roll protection for the cabin occupants. The cabin and baggage compartment floors are constructed of a foam core composite with access to under-floor components.

All flight and static loads are transferred to the fuselage structure from the wings and control surfaces through four wing attach points in two locations under the front seats and two locations on the sidewall just aft of the rear seats.

Serials 0795, 0820 and subsequent: The lower firewall employs a 20° bevel to improve crashworthiness. In addition, an avionics bay is located aft of bulkhead 222 and accessible through an access panel installed on the RH side of the aft fuselage.

- Note •

Refer to Airplane Cabin description in this section for a complete description of doors, windows, baggage compartment, seats, and safety equipment.

Wings

The wing structure is constructed of composite materials producing wing surfaces that are smooth and seamless. The wing cross section is a blend of several high performance airfoils. A high aspect ratio results in low drag. Each wing provides attach structure for the main landing gear and contains a 42-gallon fuel tank.

The wing is constructed in a conventional spar, rib, and shear section arrangement. The upper and lower skins are bonded to the spar, ribs, and shear sections (rear spars) forming a torsion box that carries all of the wing bending and torsion loads. The wing spar is manufactured in one piece and is continuous from wing tip to wing tip. The shear webs (rear spars) are similar in construction but do not carry through the

fuselage. The main wing spar passes under the fuselage below the two front seats and is attached to the fuselage in two locations. The rear shear webs are attached to the fuselage sidewalls just aft of the rear seats.

Empennage

The empennage consists of a horizontal stabilizer, a two-piece elevator, a vertical fin and a rudder. All of the empennage components are conventional spar (shear web), rib, and skin construction.

The horizontal stabilizer is a single composite structure from tip to tip. The two-piece elevator, attached to the horizontal stabilizer, is aluminum.

The vertical stabilizer is composite structure integral to the main fuselage shell for smooth transfer of flight loads. The rudder is aluminum and is attached to the vertical stabilizer rear shear web at three hinge points.

Flight Controls

The SR22 uses conventional flight controls for ailerons, elevator and rudder. The control surfaces are pilot controlled through either of two single-handed side control yokes mounted beneath the instrument panel. The location and design of the control yokes allow easy, natural use by the pilot. The control system uses a combination of push rods, cables and bell cranks for control of the surfaces.

Roll trim and pitch trim are available through an electric button on the top of each control yoke. Electric yaw trim, if installed, is accomplished by operating a switch on the forward console immediately to the left of the Flaps switch.

Elevator System

The two-piece elevator provides airplane pitch control. The elevator is of conventional design with skin, spar and ribs manufactured of aluminum. Each elevator half is attached to the horizontal stabilizer at two hinge points and to the fuselage tailcone at the elevator control sector.

Elevator motion is generated through the pilot's control yokes by sliding the yoke tubes forward or aft in a bearing carriage. A push-pull linkage is connected to a cable sector mounted on a torque tube. A single cable system runs from the forward elevator sector under the cabin floor to the aft elevator sector pulley. A push-pull tube connected to the aft elevator sector pulley transmits motion to the elevator bellcrank attached to the elevators.

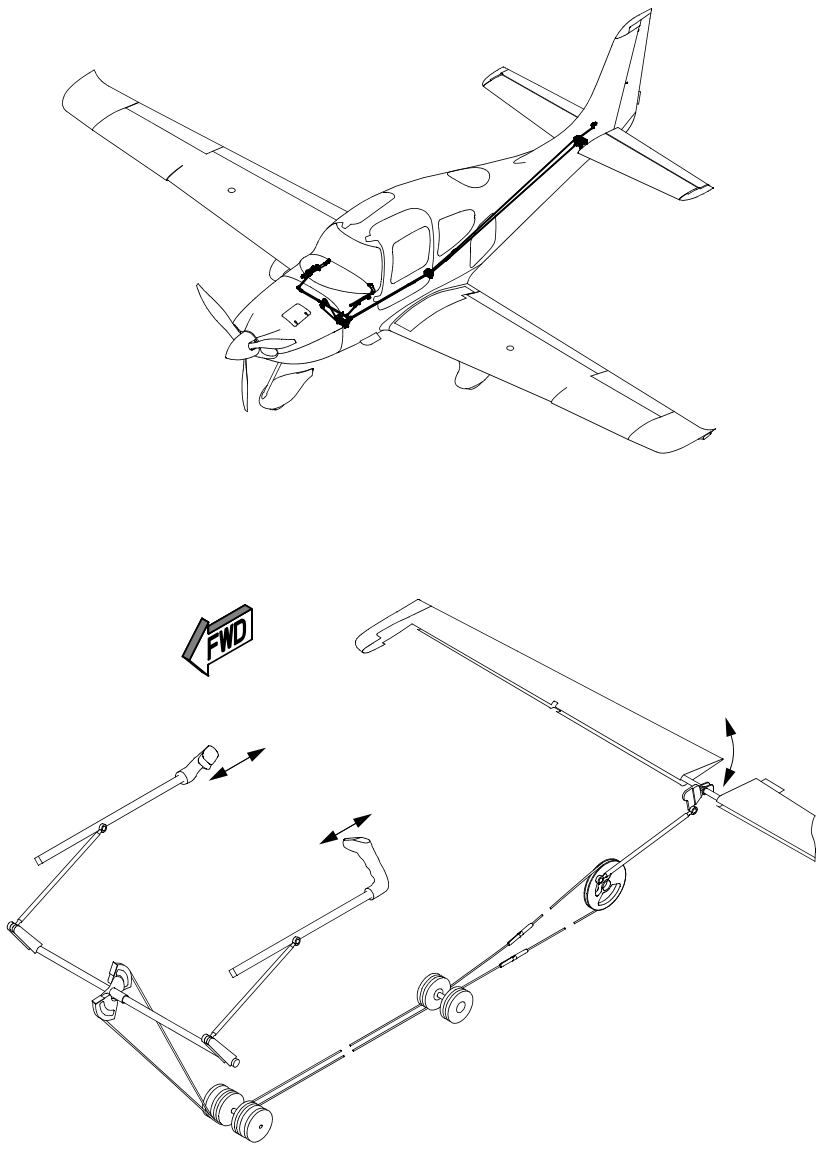

SR22_FM07_1461

Figure 7-1
Elevator Control System

Aileron System

The ailerons provide airplane roll control. The ailerons are of conventional design with skin, spar and ribs manufactured of aluminum. Each aileron is attached to the wing shear web at two hinge points.

Aileron control motion is generated through the pilot's control yokes by rotating the yokes in pivoting bearing carriages. Push rods link the pivoting carriages to a centrally located pulley sector. A single cable system runs from the sector to beneath the cabin floor and aft of the rear spar. From there, the cables are routed in each wing to a vertical sector/crank arm that rotates the aileron through a right angle conical drive arm.

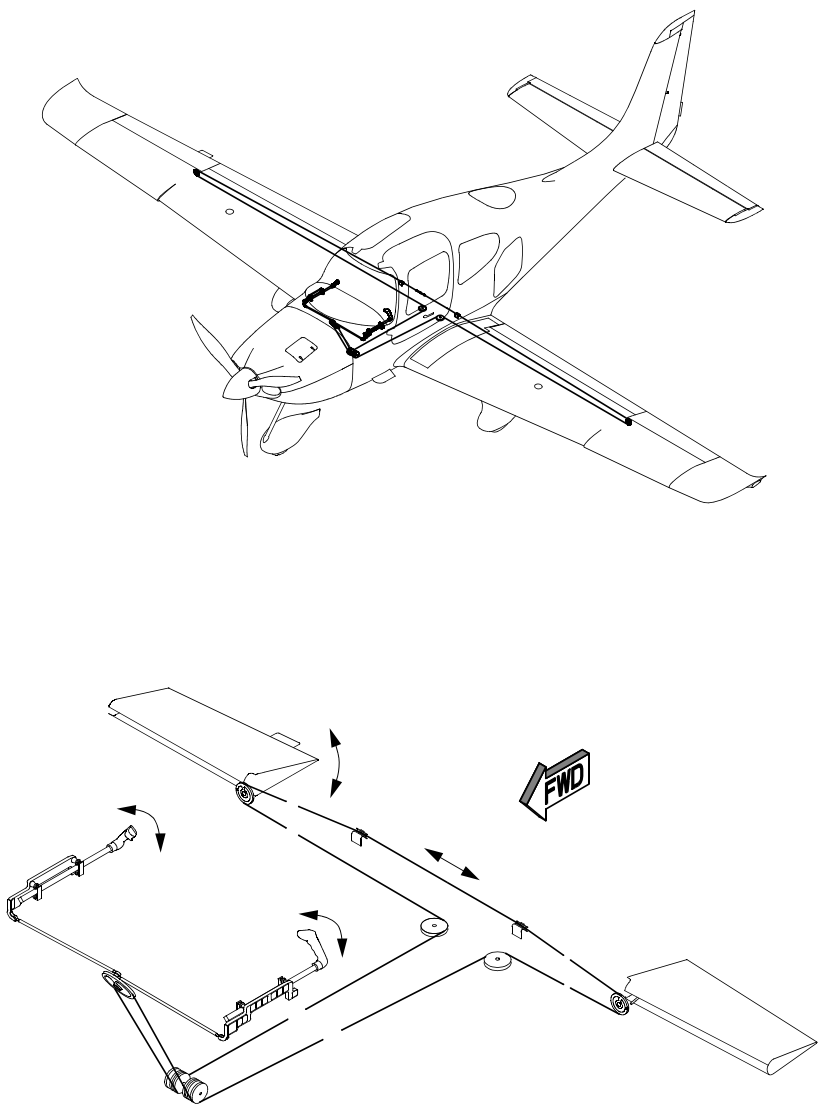

SR22_FM07_1462

Figure 7-2
Aileron Control System

Rudder System

The rudder provides airplane directional (yaw) control. The rudder is of conventional design with skin, spar and ribs manufactured of aluminum. The rudder is attached to the aft vertical stabilizer shear web at three hinge points and to the fuselage tailcone at the rudder control bell crank.

Rudder motion is transferred from the rudder pedals to the rudder by a single cable system under the cabin floor to a sector next to the elevator sector pulley in the aft fuselage. A push-pull tube from the sector to the rudder bell crank translates cable motion to the rudder. Springs and a ground adjustable spring cartridge connected to the rudder pedal assembly tension the cables and provide centering force.

A rudder-aileron interconnect is installed to provide a maximum of 5° down aileron with full rudder deflection. Right rudder input will cause right roll input and left rudder input will cause left roll input. With neutral aileron trim, aileron inputs will not cause rudder deflection.

On some airplanes, an electrically operated trim tab on the trailing edge of the rudder allows pilot-operated rudder trim. Airplanes without electric rudder trim have a ground adjustable trim tab installed.

Control Locks

The Cirrus SR22 control system is not equipped with gust locks. The trim spring cartridges have sufficient power to act as a gust damper without rigidly locking the position.

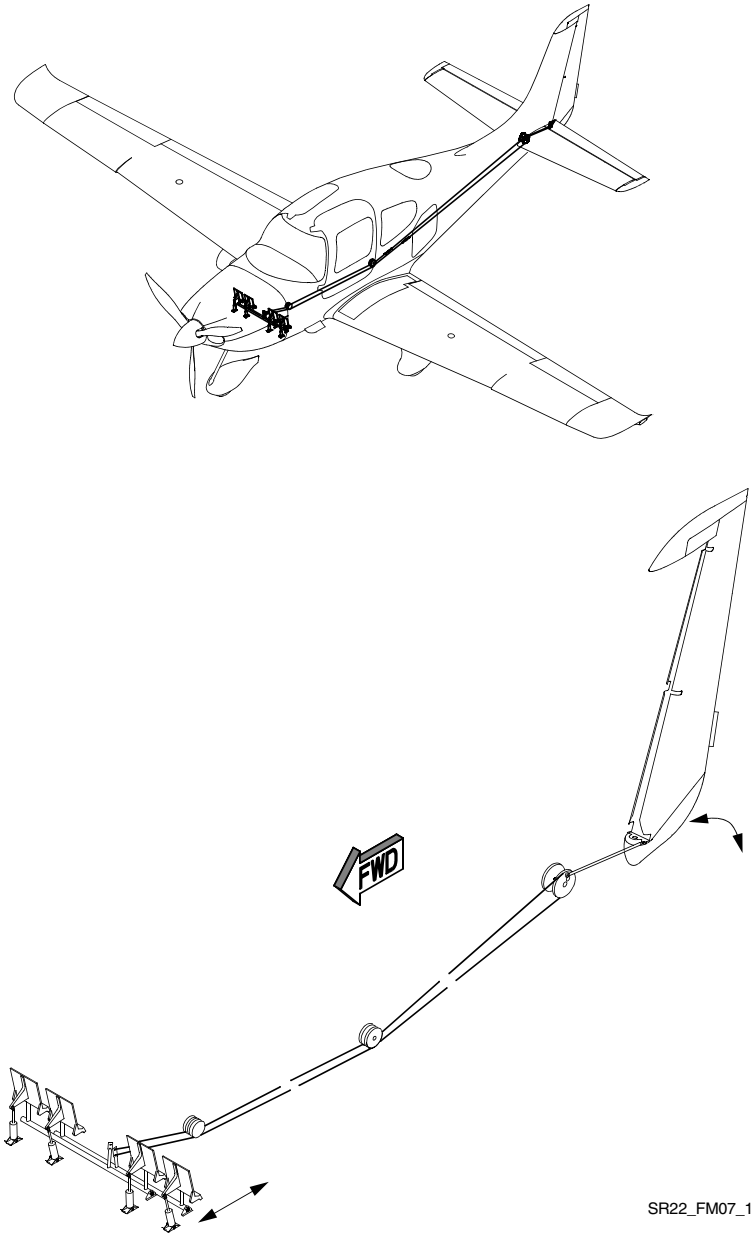

SR22_FM07_1463

Figure 7-3
Rudder Control System

Trim Systems

Roll and pitch trim are provided by adjusting the neutral position of a compression spring cartridge in each control system by means of an electric motor. The electric roll trim is also used by the autopilot to position the ailerons. An electrically actuated trim tab on the rudder, if installed, provides rudder trim. It is possible to easily override full trim or autopilot inputs by using normal control inputs.

Ground adjustable trim tabs are installed on the elevator and right aileron to provide small adjustments in neutral trim. On airplanes without electric rudder trim, a ground adjustable trim tab is installed on the rudder. These tabs are factory set and do not normally require adjustment.

Pitch Trim Control System

An electric motor changes the neutral position of the spring cartridge attached to the elevator control horn. A conical trim button located on top of each control yoke controls the motor. Moving the switch forward will initiate nose-down trim and moving the switch aft will initiate nose-up trim. Neutral (takeoff) trim is indicated by the alignment of a reference mark on the yoke tube with a tab attached to the instrument panel bolster. The elevator trim also provides a secondary means of aircraft pitch control in the event of a failure in the primary pitch control system not involving a jammed elevator. Elevator (pitch) trim operates on 28 VDC supplied through the 2-amp PITCH / YAW TRIM circuit breaker on Main Bus 1.

Roll Trim Control System

An electric motor changes the neutral position of a spring cartridge attached to the left actuation pulley in the wing. A conical trim button located on top of each control yoke controls the motor. Moving the switch left will initiate left-wing-down trim and moving the switch right will initiate right-wing-down trim. Neutral trim is indicated by the alignment of the line etched on the control yoke with the centering indication marked on the instrument panel. The aileron trim also provides a secondary means of aircraft roll control in the event of a failure in the primary roll control system not involving jammed ailerons. Aileron trim operates on 28 VDC supplied through the 2-amp ROLL TRIM circuit breaker on Main Bus 1.

Yaw Trim System

Yaw trim is provided by spring cartridge attached to the rudder pedal torque tube and console structure. The spring cartridge provides a centering force regardless of the direction of rudder deflection. The yaw trim is ground adjustable only.

On airplanes with electric rudder (yaw) trim, trim changes are pilot controlled through a linear actuator connected to a hinged trim tab on the rudder trailing edge. The actuator is installed in the rudder. A RUDDER TRIM indicator with integral rocker switch is mounted in the console immediately adjacent to the FLAP control switch. Pressing the left half of the switch initiates Nose L trim and pressing the right half initiates Nose R trim. A needle sweeps the trim indicator scale to indicate trim position. The full Nose Right trim tic is labeled TAKEOFF. Rudder (yaw) trim operates on 28 VDC supplied through the 2-amp PITCH / YAW TRIM circuit breaker on Main Bus 1. The switch and indicator are not internally illuminated.

Flight Deck Arrangement

The following paragraphs are a general description of the flight deck, instrumentation, and controls. The instrument panel is designed for glare-free use in all flight conditions. The instrument panel is arranged primarily for use by the pilot in the left seat; however, it can be viewed from either seat. For details relating to the instrumentation, switches, circuit breakers, and controls on the instrument panel, bolster, and center console, refer to the related topics in this section.

Instrument Panel

Serials 0002 through 1601, 1603 through 1643 and 1645 through 1662 without PFD: Flight instruments and annunciators are located on the left side of the panel and engine instruments are located on the right side of the instrument panel. A large color multifunction display is located between the flight instruments and the engine instruments. Temperature controls are located on the right side below the engine instruments.

The SR22 uses standard flight instruments arranged in the 'basic-six' pattern. They include:

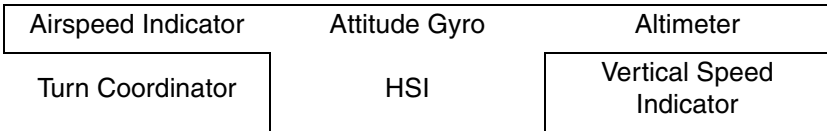

Serials 0002 through 0434, an electronic clock and VOR/LOC/ILS (CDI) are located immediately to the left of the flight instruments on the instrument panel.

A switch panel located in the “dash board” bolster below the flight instruments contains the master and ignition switches, avionics power switch, pitot heat switch, and lighting switches.

Serials 0435 and subsequent with PFD: The airplane is equipped with an Avidyne FlightMax Entegra-Series Primary Flight Display (PFD). The PFD is a 10.4" landscape-oriented display intended to be the primary display of primary flight parameter information (attitude, airspeed, heading, and altitude) to the pilot. The PFD accepts data from a variety of sources, including the GPS sensors, the System 55X Autopilot, and is the primary heading source for the Multifunction Display.

Standby altimeter, airspeed, and attitude indicators are mounted on the bolster panel in case of total or partial PFD failure. To provide roll data to the autopilot system, a Turn Coordinator is mounted behind the RH bolster panel.

Annunciators and the ignition switch are located on the left side of the panel and a large color multifunction display is located adjacent to the primary flight display. Temperature controls are located on the right side below the glove compartment.

A switch panel located in the "dash board" bolster below the flight instruments contains the master switch, avionics power switch, pitot heat switch, and lighting switches.

Center Console

A center console contains the avionics, flap control and position lights, power lever and mixture controls, fuel system indicator and controls, and audio controls. System circuit breakers, the alternate static source valve, alternate induction air control, and ELT panel switch are located on the left side of the console for easy access by the pilot. A friction knob for adjusting throttle and mixture control feel and position stability is located on the right side of the console. An accessory outlet, map compartment, audio jacks, hour meter, emergency egress hammer, and headset jacks are installed inside the console armrest.

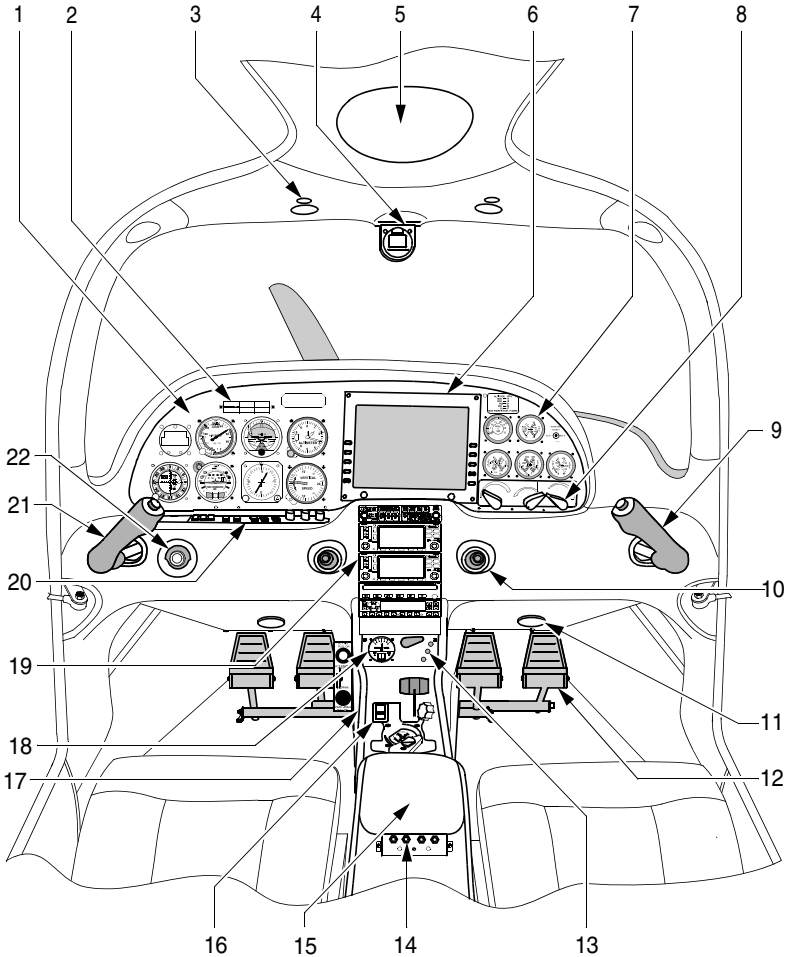

Legend

- | | | |
|--|--|---|
| <ul style="list-style-type: none"> 1. Flight Instrument Panel 2. Annunciator Panel 3. Overhead Light & Switch 4. Magnetic Compass 5. Cirrus Airframe Parachute System (CAPS) Activation T-Handle Cover 6. Multifunction Display 7. Engine Instruments 8. Temperature/Ventilation Controls 9. Control Yoke 10. Fresh Air "Eyeball" Outlet | <ul style="list-style-type: none"> 11. Conditioned Air Outlet 12. Rudder Pedals 13. Flap Control & Position Indicators 14. Passenger Audio Jacks 15. Armrest 16. Engine & Fuel System Controls 17. Left Side Console <ul style="list-style-type: none"> - Circuit Breaker Panel - Alternate Engine Air - Parking Brake - Alternate Static Source | <ul style="list-style-type: none"> 18. Rudder Trim Switch/Indicator 19. Avionics Panel 20. Bolster Switch Panel 21. Control Yoke 22. Start/Ignition Key Switch |
|--|--|---|

SR22_FM07_1455B

Figure 7-4
Instrument Panel and Console (Sheet 1 of 3)

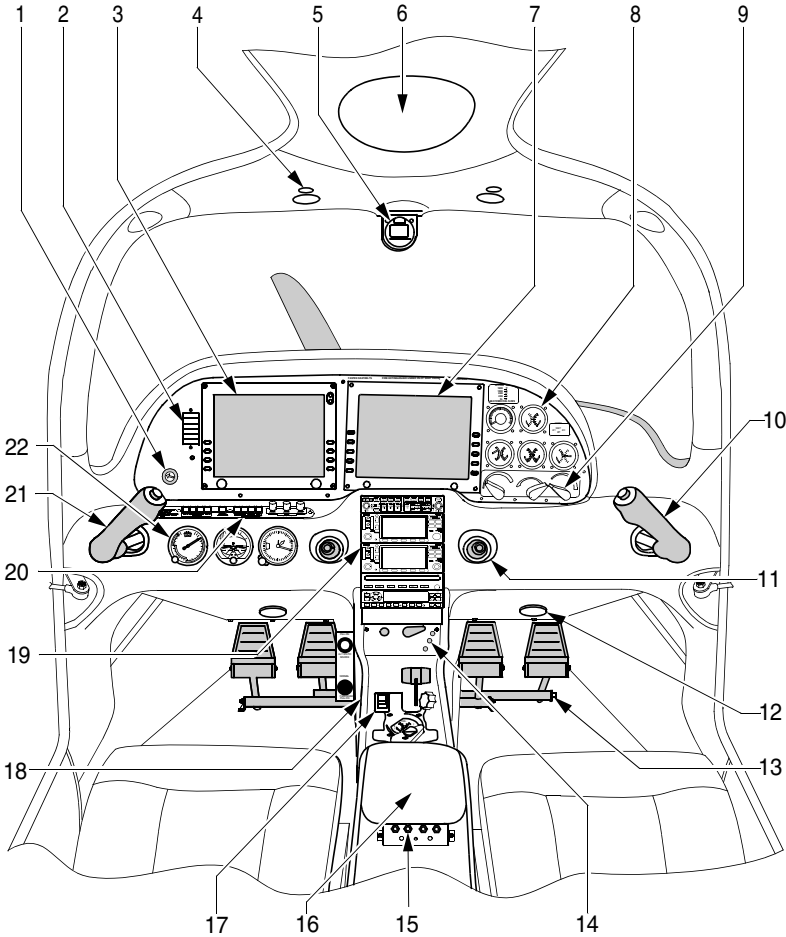

Legend

- | | | |
|--|--|-----------------------------|
| 1. Start/Ignition Key Switch | 9. Temperature/Ventilation Controls | 18. Left Side Console |
| 2. Annunciator Panel | 10. Control Yoke | · Circuit Breaker Panel |
| 3. Primary Flight Display | 11. Fresh Air "Eyeball" Outlet | · Alternate Engine Air |
| 4. Overhead Light & Switch | 12. Conditioned Air Outlet | · Parking Brake |
| 5. Magnetic Compass | 13. Rudder Pedals | · Alternate Static Source |
| 6. Cirrus Airframe Parachute System (CAPS) Activation T-Handle Cover | 14. Flap Control & Position Indicators | 19. Avionics Panel |
| 7. Multifunction Display | 15. Passenger Audio Jacks | 20. Bolster Switch Panel |
| 8. Engine Instruments | 16. Armrest | 21. Control Yoke |
| | 17. Engine & Fuel System Controls | 22. Flight Instrument Panel |

SR22_FM07_1730

Figure 7-4
Instrument Panel and Console (Sheet 2 of 3)

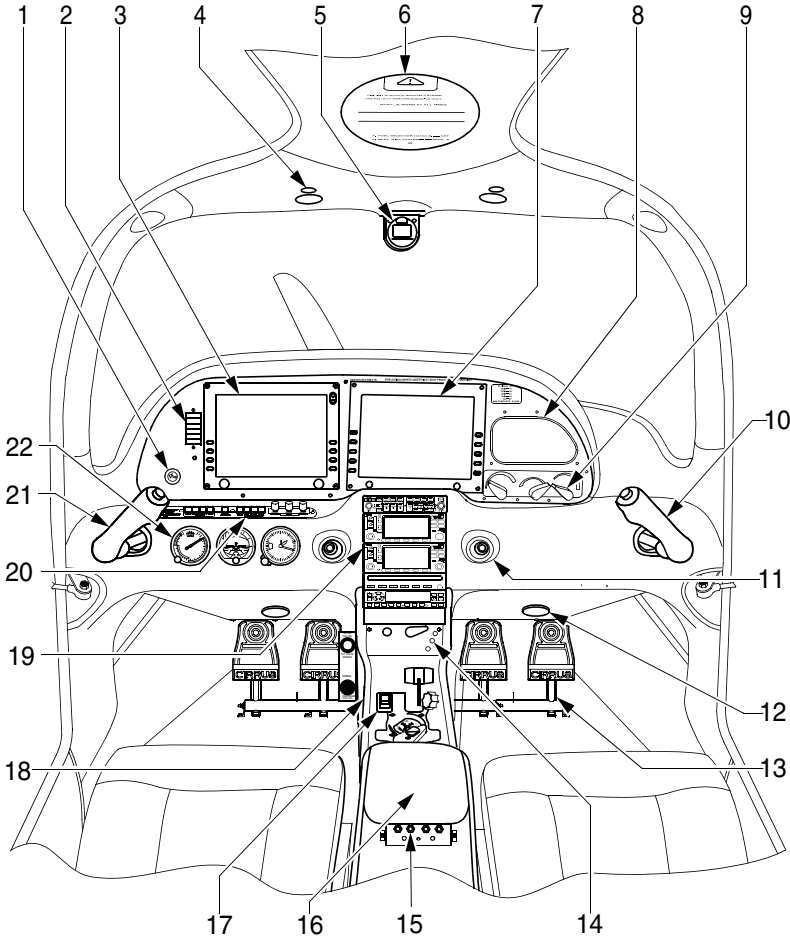

Legend

- | | | |
|--|--|-----------------------------|
| 1. Start/Ignition Key Switch | 9. Temperature/Ventilation Controls | 18. Left Side Console |
| 2. Annunciator Panel | 10. Control Yoke | - Circuit Breaker Panel |
| 3. Primary Flight Display | 11. Fresh Air "Eyeball" Outlet | - Alternate Engine Air |
| 4. Overhead Light & Switch | 12. Conditioned Air Outlet | - Parking Brake |
| 5. Magnetic Compass | 13. Rudder Pedals | - Alternate Static Source |
| 6. Cirrus Airframe Parachute System (CAPS) Activation T-Handle Cover | 14. Flap Control & Position Indicators | 19. Avionics Panel |
| 7. Multifunction Display | 15. Passenger Audio Jacks | 20. Bolster Switch Panel |
| 8. Glove Box | 16. Armrest | 21. Control Yoke |
| | 17. Engine & Fuel System Controls | 22. Flight Instrument Panel |

SR22_FM07_2216

Figure 7-4
Instrument Panel and Console (Sheet 3 of 3)

Flight Instruments

• Note •

For additional information on instrument limit markings, refer to *Section 2, Limitations*.

Primary Flight Display - *Serials 0435 and Subsequent*

The Primary Flight Display (PFD) provides the functions of the attitude indicator, heading indicator, airspeed indicator, altimeter, vertical speed indicator, directional gyro, course deviation indicator, and altitude pre-select controller onto a single electronic display. In addition, the PFD communicates with GPS1, GPS2, NAV1, NAV2, the Multifunction Display, and Autopilot System.

An integral air data/attitude and heading reference system (ADAHRS) uses a 3-axis solid state gyro and accelerometer system combined with a magnetometer to replace the vertical and directional gyros. ADAHRS also provides roll, pitch, heading data and continually updates the winds aloft and true airspeed (TAS) indications on the PFD. The magnetometer assembly mounted in the wing also provides outside air temperature (OAT) data.

The airplane's Pitot-Static system is connected to the PFD to provide airspeed, altitude, and vertical speed.

Standby instruments for airspeed, attitude and altitude are mounted on the LH bolster panel and are on separate power sources than the PFD.

Redundant power sources provide 28 VDC for system operation. Power is supplied through the 10-amp PFD1 circuit breaker on the Essential Bus and the 10-amp PFD2 circuit breaker on Main Bus 2. Either circuit is capable of powering the PFD. System start-up is automatic once power is applied. The display presents the Initialization Display immediately after power is applied. Power-on default is 75% brightness. Typical alignment times are 3 minutes from battery turn on.

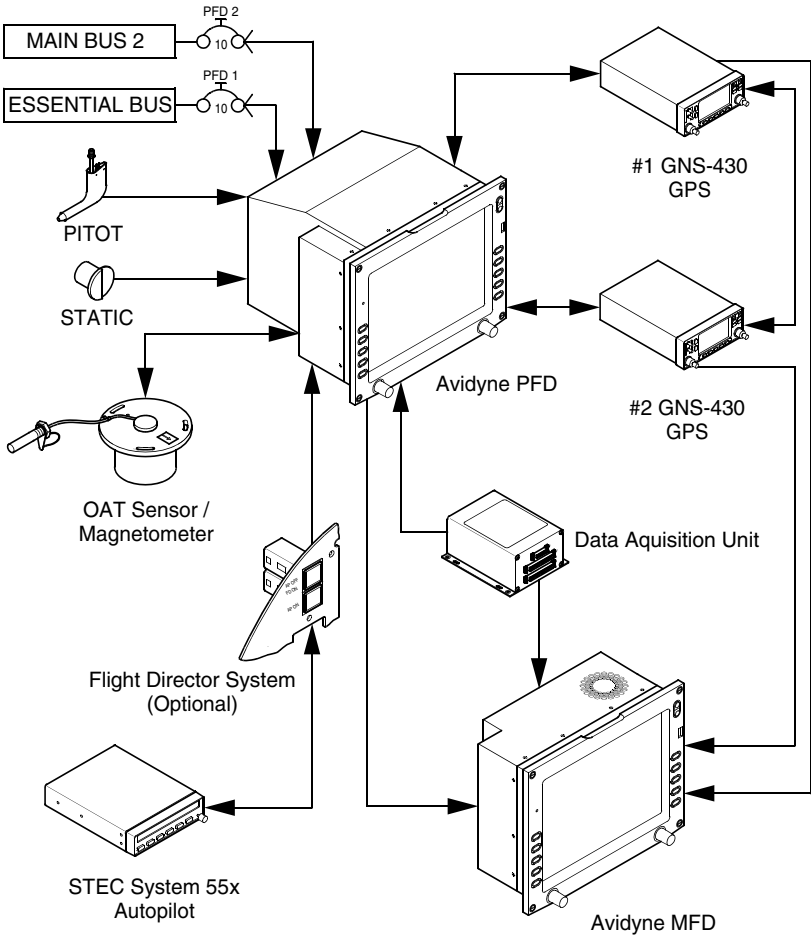

SR22_FM07_1607B

Figure 7-5
PFD System - Simplified Schematic

Attitude Direction Indicator (ADI)

Air Data

The airspeed tape to the left of the main ADI begins indicating at 20 Knots Indicated Airspeed (KIAS) and is color-coded to correspond with airspeeds for V_{SO} , V_{FE} , V_S , V_{NO} , and V_{NE} . An altitude tape is provided to the right of the main ADI and also displays a symbol for the Altitude preselect (Altitude bug). The Vertical Speed Indicator (VSI) is displayed to the right of the altitude tape. The displayed scale of the VSI is +/- 2000 FPM and for rates above 2000 FPM, the needle will peg just outside the scale and a digital readout of actual VSI up to 4000 FPM is then displayed. An additional data block is provided for display of outside air temperature (OAT), true airspeed (TAS), and groundspeed (GS). Controls for selecting bug and barometric correction values are along the right side of the PFD. A wind indicator is also provided beneath the altitude tape.

Attitude Data

Attitude is depicted on the main ADI using an aircraft reference symbol against a background of labeled pitch ladders and an arced scale along the top of the ADI to indicate bank angle. A skid/slip indicator is attached to the bottom edge of the bank angle pointer.

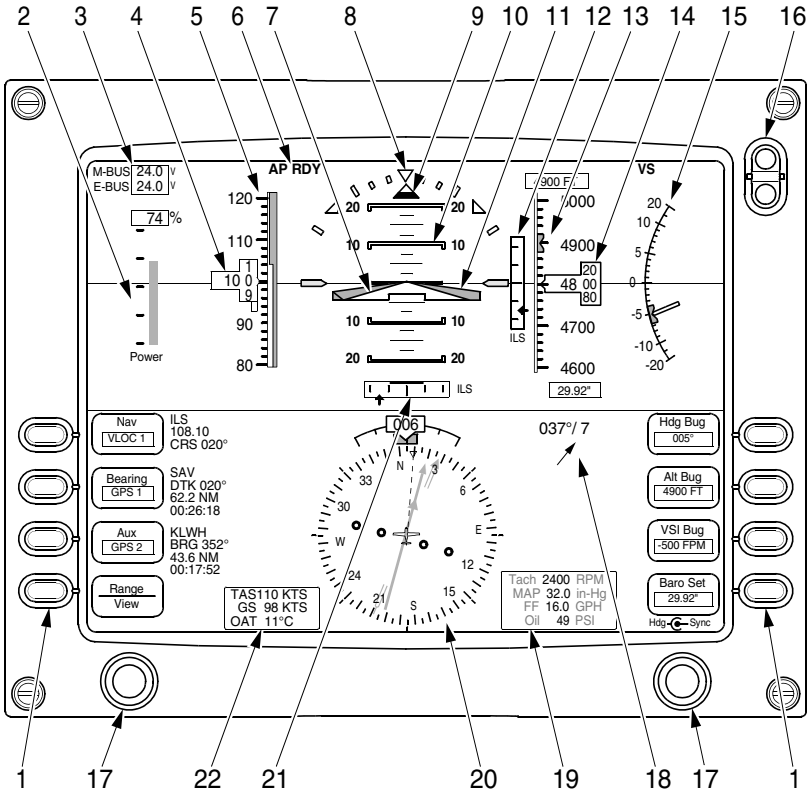

LEGEND

- | | |
|--|--|
| 1. Navigation & Avionics Configuration Buttons | 12. Vertical Deviation Indicator (VDI) |
| 2. Percent Power | 13. Altitude Tape |
| 3. Bus Voltages | 14. Altitude Window |
| 4. Airspeed Window | 15. Vertical Speed Indicator (VSI) |
| 5. Airspeed Tape | 16. Brightness Control (BRT/DIM) |
| 6. Autopilot Annunciations | 17. Mode and Display Selection |
| 7. Aircraft Reference Symbol | 18. Wind Vector |
| 8. Bank Angle Indicator | 19. Engine Information Data Block |
| 9. Skid/Slip Indicator | 20. Horizontal Situation Indicator (HSI) |
| 10. Pitch Ladder | 21. Horizontal Deviation Indicator (HDI) |
| 11. Flight Director Steering Command Bars | 22. Air Data Block |

SR22_FM07_2221A

Figure 7-6
Primary Flight Display

Horizontal Situation Indicator (HSI)

Heading Data

Magnetic heading is represented in boxed numeric form at the top of the compass rose. Heading rate (Rate of Turn Indicator) takes the form of a blue arcing arrow that begins behind the magnetic heading indicator and moves left or right accordingly. Graduations are provided on the rate-of-turn indicator scale to indicate half and full standard-rate turns. A heading bug is also provided on the compass rose.

Navigation Data

Navigation data on the PFD takes several forms. A course deviation indicator (CDI) is always provided on the HSI and a bearing pointer can be optionally selected for display on the HSI by the pilot. Controls for selecting the source of navigation data, selecting the display format of the navigation data, and for selecting the type of compass rose and moving map to be displayed are along the left side of the PFD. The active flight plan contained in the GPS Nav/Com unit selected as the primary navigation source (Nav) can be optionally selected for display on the HSI as well as the desired range of the optionally selectable moving map display. If a localizer or ILS frequency is tuned and captured in the GPS Nav/Com selected as the Nav source, a vertical deviation indicator (VDI) and horizontal deviation indicator (HDI) are automatically displayed on the ADI.

- Note •

In the event glide slope or localizer signals are lost, the HDI and/or VDI will be displayed as red-“X”s to indicate loss of signal. The red-“X”-ed indicator will only be removed if the signal is regained, the Nav Source is changed on the PFD, or if the GPS Nav/Com is retuned to another frequency. Appropriate action must be taken by the pilot if on an approach.

For a detailed description of the PFD, *refer to the Avidyne FlightMax Entegra-Series PFD Pilot's Guide.*

Attitude Indicator

• Note •

Serials 0435 and subsequent with PFD: The attitude indicator is mounted on the LH bolster panel.

The attitude indicator gives a visual indication of flight attitude. Bank attitude is indicated by a pointer at the top of the indicator relative to the bank scale with index marks at 10°, 20°, 30°, 60°, and 90° either side of the center mark. A fixed miniature airplane superimposed over a movable mask containing a white symbolic horizon bar, which divides the mask into two sections, indicates pitch and roll attitudes. The upper “blue sky” section and the lower “earth” sections have pitch reference lines useful for pitch attitude control. The indicator can follow maneuvers through 360° in roll and 360° in pitch. A knob at the bottom of the instrument allows adjustment of the miniature airplane to the horizon bar for a more accurate flight attitude indication.

A PULL TO CAGE knob on the indicator is used for quick erection of the gyro. When the caging knob is pulled, the pitch and roll indications will align to within 2° of their respective fixed references.

The instrument is electrically driven and a red GYRO flag indicates loss of electrical power. Redundant circuits paralleled through diodes at the indicator supply DC electrical power for gyro operation. 28 VDC for attitude gyro operation is supplied through the 3-amp Attitude #1 circuit breaker on the Essential Bus and the 3-amp Attitude #2 circuit breaker on the Main Bus 2.

Airspeed Indicator

• Note •

Serials 0435 and subsequent with PFD: The standby airspeed indicator is mounted on the LH bolster panel.

Indicated and true airspeeds are indicated on a dual-scale, internally lit precision airspeed indicator installed in the pilot's instrument panel. The instrument senses difference in static and Pitot pressures and displays the result in knots on an airspeed scale. A single pointer sweeps an indicated airspeed scale calibrated from 40 to 220 knots. The 'zero' index is at the 12 o'clock position. A sub-scale aligns true airspeed with the corresponding indicated airspeed when the altitude/

temperature correction is set in the correction window. A knob in the lower left corner of the instrument is used to rotate the pressure altitude scale in the correction window to align the current pressure altitude with the outside air temperature.

Vertical Speed Indicator

- Note •

Serials 0435 and subsequent with PFD: The Vertical Speed Indicator is integrated into the PFD.

Airplane rate of climb or descent in feet per minute is displayed on the internally lit Vertical Speed indicator installed in the pilot's instrument panel. The instrument senses rate of change in static pressure from a reference pressure and displays the result in climb or descent feet per minute (FPM). Climb is indicated by clockwise rotation of the pointer from zero and descent is indicated by counter clockwise rotation. The '0' (zero) reference point is at the 9 o'clock position. The scale is calibrated from 0 to 2000 FPM in 100-FPM increments in both the 'UP' and 'DOWN' directions.

Altimeter

- Note •

Serials 0435 and subsequent with PFD: The standby altimeter is mounted on the LH bolster panel.

Airplane altitude is depicted on a conventional, three-pointer, internally lit barometric altimeter installed in the pilot's instrument panel. The instrument senses the local barometric pressure adjusted for altimeter setting and displays the result on the instrument in feet. The altimeter is calibrated for operation between -1000 and 20,000 feet altitude. The scale is marked from 0 to 10 in increments of 2. The long pointer indicates hundreds of feet and sweeps the scale every 1000 feet (each increment equals 20 feet). The short, wide pointer indicates thousands of feet and sweeps the scale every 10,000 feet (each increment equals 200 feet). The short narrow pointer indicates tens of thousands feet and sweeps from 0 (zero) to 2 (20,000 feet with each increment equal to 2000 feet). Barometric windows on the instrument's face allow barometric calibrations in either inches of mercury (in.Hg) or millibars

(mb). The barometric altimeter settings are input through the barometric adjustment knob at the lower left of the instrument.

Turn Coordinator

• Note •

Serials 0435 and subsequent with PFD: Turn Coordinator function and roll data display is integrated into the PFD.

Serials with Avionics Configuration A - 0002 through 1601, 1603 through 1643 and 1645 through 1662 without PFD: The electric turn coordinator displays roll information and provides roll data to the integral System 30 autopilot. Roll rate is sensed by a single-gimbal, electric-powered gyro and displayed on the face of the instrument. The display consists of a symbolic airplane rotates to indicate turn rate and a standard glass tube and ball inclinometer. Markings, labeled L & R, indicate roll for a standard rate turn in the direction indicated. Redundant circuits paralleled through diodes at the indicator supply DC electrical power. 28 VDC for roll rate gyro operation is supplied through the 2-amp TURN COORD #1 circuit breaker on the Essential Bus and the 2-amp TURN COORD #2 circuit breaker on the Main Bus 2.

Serials with Avionics Configuration B - 0002 through 1601, 1603 through 1643 and 1645 through 1662 without PFD: The electric turn coordinator, installed in the instrument panel, displays roll information and provides roll data to the System 55X autopilot. The instrument and power supplies are as described above.

Course Deviation Indicator

• Note •

Serials 0435 and subsequent with PFD: The Course Deviation Indicator is integrated into the PFD.

Serials with Avionics Configuration A - 0002 through 1601, 1603 through 1643 and 1645 through 1662 without PFD: The Course Deviation Indicator (CDI) displays navigation information from GPS 2 (Garmin GNC 420). The CDI displays GPS track deviation on a single deviation bar instrument. A vertical line displays GPS track deviation against a 5-dot scale. The indicator incorporates TO/FROM annunciation and NAV flag. An OBS knob is used to manually rotate

the azimuth card to the desired bearing. 28 VDC for lighting is supplied through the 2-amp INST LIGHTS circuit breaker on Main Bus 1.

Serials with Avionics Configuration B - 0002 through 1601, 1603 through 1643 and 1645 through 1662 without PFD: The Course Deviation Indicator (CDI) displays navigation information from GPS 2 (Garmin GNS 430). Navigation source selection is made using the CDI button on the GPS 2 control. The CDI displays course deviation from a VOR or Localizer (LOC) and Glideslope when 'VLOC' is the selected navigation source and displays GPS track deviation when 'GPS' is the selected navigation source. The instrument has two deviation bars. The vertical line displays VOR/LOC or GPS track deviation against a 5-dot scale. The horizontal line displays glideslope deviation against a 5-dot scale. The indicator incorporates TO/FROM annunciation, NAV flag, and GS flag. An OBS knob is used to manually rotate the azimuth card to the desired bearing. 28 VDC for instrument lighting is supplied through the 2-amp INST LIGHTS circuit breaker on Main Bus 1.

Horizontal Situation Indicator

• Note •

Serials 0435 and subsequent with PFD: The Horizontal Situation Indicator is integrated into the PFD.

Serials with Avionics Configuration A - 0002 through 1601, 1603 through 1643 and 1645 through 1662 without PFD: The Century NSD-1000 is a conventional HSI that provides gyro stabilized, magnetically slaved, heading information, a pictorial VOR/LOC display with a conventional course arrow, and glideslope presentation. The instrument displays airplane heading by rotating a compass dial in relation to a fixed simulated airplane image and lubber line. The HSI directional gyro, which drives the compass dial, is slaved to a flux detector in the right wing through an amplifier under the copilot's floor. A FREE GYRO-SLAVE switch, below the display, allows the pilot to select either Free Gyro mode or Slave mode. In Slave mode, the gyro is slaved to the flux detector. In Free Gyro mode, the gyro must be manually set to the airplane's magnetic compass using the PUSH-SET-CARD knob in the lower right corner of the instrument. The course is set using the Course (Arrow) knob in the lower left corner of the instrument. The HSI course and heading outputs provided to the

autopilot to allow NAV/LOC/GPS course tracking or to track a preset heading.

The HSI incorporates conventional warning flags. The HDG (Heading) flag will be out of view whenever the instrument is receiving sufficient electrical power for operation. The NAV (Navigation) flag will be out of view when a VOR or LOC frequency is tuned in the NAV1 receiver and a reliable signal is present. The GS (Glideslope) flag will be out of view when an ILS frequency is tuned on the Nav 1 receiver and a reliable GS signal is present.

The NSD-1000 HSI is electrically driven and a red GYRO flag indicates loss of electrical power. Redundant circuits paralleled through diodes at the indicator supply DC electrical power for gyro operation. 28 VDC for the redundant power circuits is supplied through the 5-amp HSI 1 circuit breaker on the Essential Bus and 5-amp HSI 2 circuit breaker on Main Bus 2.

Serials with Avionics Configuration B - 0002 through 1601, 1603 through 1643 and 1645 through 1662 without PFD: The Sandel SN3308 combines the functions of an HSI, an RMI, a full color moving map, a Stormscope display, GPS annunciator, and 3-light marker beacon indicators. Compass information is derived from a remote directional gyro and a flux detector. Redundant power sources provide 28 VDC for system operation. Power is supplied through the 5-amp HSI #1 circuit breaker on the Essential Bus and the 5-amp HSI #2 circuit breaker on Main Bus 2. Either circuit is capable of powering the Navigation Display.

The full-color display uses a rear-projection system driven by an active matrix LCD display. The unit uses a halogen lamp as the singular primary display projection light source. A separate dimming knob for the display brightness is provided immediately below the display.

The HSI display shows heading and navigation information in a 360° view similar to a conventional mechanical HSI, or in an EFIS 90° ARC view. This includes compass card, heading bug, course pointer, course deviation bar, TO/FROM indicator, glideslope indicator, and flags. Heading bug and course pointer settings include digital readouts that make it easy to set precise headings and courses. One button operation allows primary navigation to be selected from up to four different sources: two VOR/ILS receivers and two GPS receivers. Either GPS1 or NAV1 may be selected as primary navigation sources.

Up to two bearing pointers can be displayed and switched to any NAV receiver including GPS1, GPS2, NAV1, or NAV2. GPS2 and NAV2 can only be displayed as bearing pointers, not as a primary navigation source. The display is color-coded to indicate which navigation source is selected: green for NAV1, yellow for NAV2, and red for GPS.

Auto Slew automatically turns the course pointer in response to waypoint sequencing or Direct-To navigation from the GPS receiver eliminating manual course changes at waypoints and reducing pilot workload.

Heading and Course Sync allows the pilot, with one button, to automatically set the heading bug directly to his current heading, or to set the course pointer directly to a VOR station, simultaneously centering course deviation. Course and heading command outputs for autopilot operations are also provided.

The SN3308 detects and warns of abnormal conditions such as flagged navigation receivers and failed directional gyro or flux detector. It also monitors its own internal temperature and provides warnings for over-temperature or loss of cooling conditions.

Redundant circuits paralleled through diodes at the indicator supply DC electrical power for gyro operation. 28 VDC for the redundant power circuits is supplied through the 5-amp HSI 1 circuit breaker on the Essential Bus and 5-amp HSI 2 circuit breaker on Main Bus 2.

Auto Slew automatically turns the course pointer in response to waypoint sequencing or Direct-To navigation from the GPS receiver eliminating manual course changes at waypoints and reducing pilot workload.

Heading and Course Sync allows the pilot, with one button, to automatically set the heading bug directly to his current heading, or to set the course pointer directly to a VOR station, simultaneously centering course deviation. Course and heading command outputs for autopilot operations are also provided.

Magnetic Compass

A conventional, internally lighted, liquid filled, magnetic compass is installed on the cabin headliner immediately above the windshield. A compass correction card is installed with the compass.

Wing Flaps

The electrically controlled, single-slotted flaps provide low-speed lift enhancement. Each flap is manufactured of aluminium and connected to the wing structure at three hinge points. Rub strips are installed on the top leading edge of each flap to prevent contact between the flap and wing flap cove. The flaps are selectively set to three positions: 0%, 50% (16°) and 100% (32°) by operating the FLAP control switch. The FLAP control switch positions the flaps through a motorized linear actuator mechanically connected to both flaps by a torque tube. Proximity switches in the actuator limit flap travel to the selected position and provide position indication. The wing flaps and control circuits are powered by 28 VDC through the 15-amp FLAPS circuit breaker on the Non-Essential Bus.

Flap Control Switch

An airfoil-shaped FLAPS control switch is located at the bottom of the vertical section of the center console. The control switch is marked and has detents at three positions: UP (0%), 50% and 100% (Down). The appropriate V_{FE} speed is marked at the Flap 50% and 100% switch positions. Setting the switch to the desired position will cause the flaps to extend or retract to the appropriate setting. An indicator light at each control switch position illuminates when the flaps reach the selected position. The UP (0%) light is green and the 50% and FULL (100%) lights are yellow.

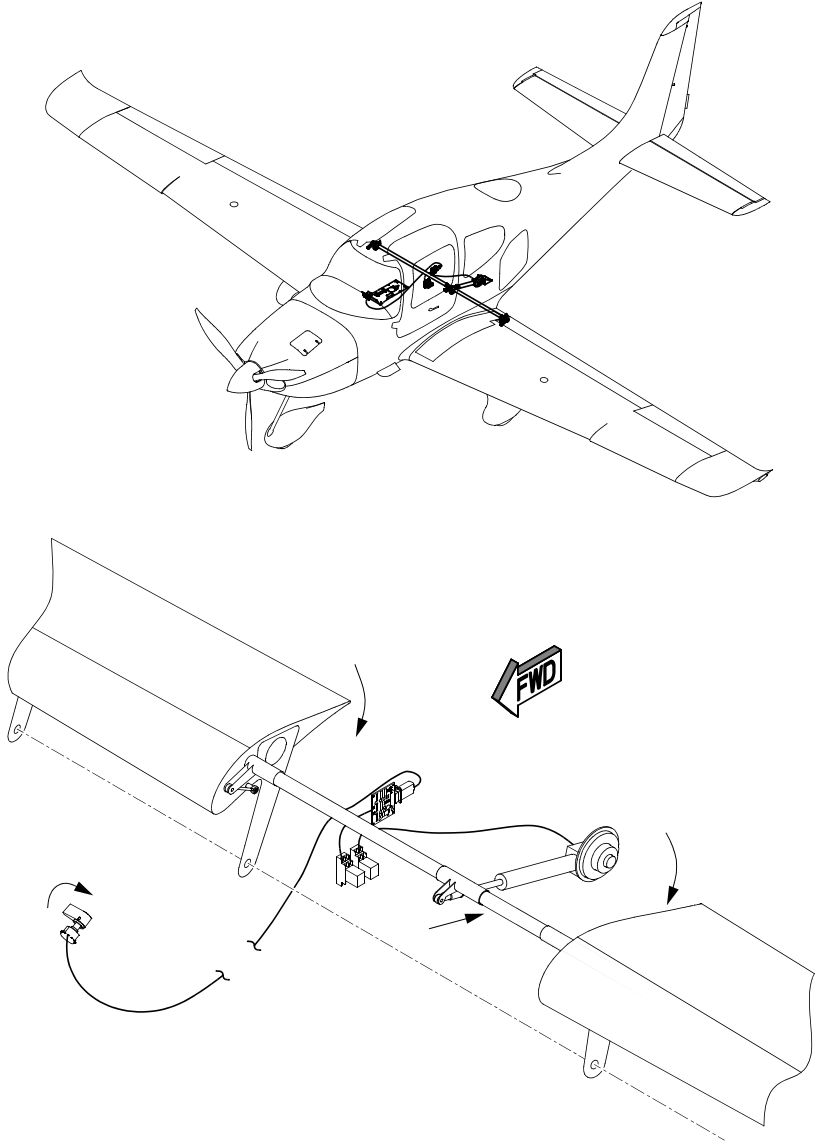

SR22_FM07_1460

Figure 7-7
Wing Flaps

Landing Gear

Main Gear

The main landing gear are bolted to composite wing structure between the wing spar and shear web. The landing gear struts are constructed of composite material for fatigue resistance. The composite construction is both rugged and maintenance free. The main wheels and wheel pants are bolted to the struts. Each main gear wheel has a 15 x 6.00 x 6 tire with inner-tube installed. Standard wheel pants are easily removable to provide access to tires and brakes. Access plugs in the wheel pants can be removed to allow tire inflation and pressure checking. Each main gear wheel is equipped with an independent, hydraulically operated, single-disc type brake.

Nose Gear

The nose gear strut is of tubular steel construction and is attached to the steel engine mount structure. The nosewheel is free casting and can turn through an arc of approximately 216 degrees (108 degrees either side of center). Steering is accomplished by differential application of individual main gear brakes. The tube-type nosewheel tire is 5.00 x 5.

Airplane Cabin

Cabin Doors

• **Caution** •

Serials 0795, 0820 and subsequent: The seat back must be in the fully upright or the fully reclined position before closing the cabin door. Seat backs in the forward or break-over position can cause damage to the door handle or interior panel.

Two large forward hinged doors allow crew and passengers to enter and exit the cabin. The door handles engage latching pins in the door frame receptacles at the upper aft and lower aft door perimeter. Gas charged struts provide assistance in opening the doors and hold the doors open against gusts. Front seat armrests are integrated with the doors. A key lock in each door provides security. The cabin door keys also fit the baggage compartment door lock. Separate keys are provided for the fuel caps.

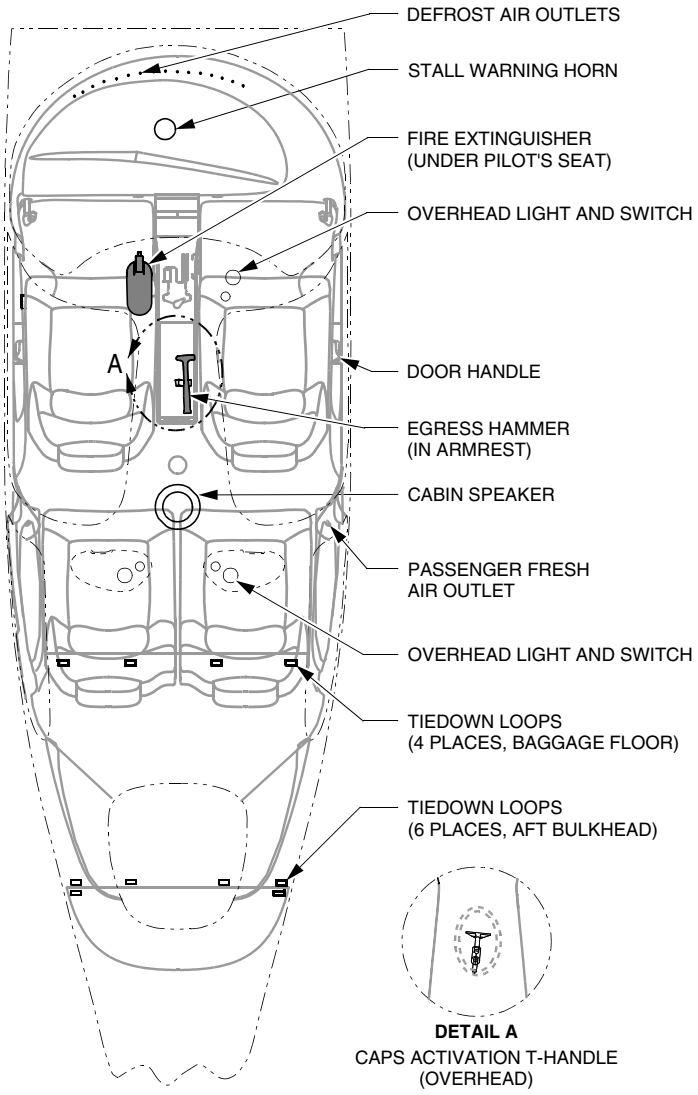

SR22_FM07_1064

Figure 7-8
Cabin Arrangement

Baggage Compartment

The baggage compartment door, located on the left side of the fuselage aft of the wing, allows entry to the baggage compartment. The baggage door is hinged on the forward edge and latched on the rear edge. The door is locked from the outside with a key lock. The baggage compartment key will also open the cabin doors.

The baggage compartment extends from behind the rear passenger seat to the aft cabin bulkhead. The rear seats can be folded forward to provide additional baggage area for long or bulky items.

Four baggage tie-down straps are provided to secure baggage and other items loaded in the baggage compartment. Each strap assembly has a hook at each end and a cam-lock buckle in the middle. The hook ends clip over loop fittings installed in the baggage floor and in the aft bulkhead. The tie-down straps should be stowed attached and tightened to the fittings. If not adequately restrained, baggage compartment items may pose a projectile hazard to cabin occupants in the event of rapid deceleration. Secure all baggage items with tie-down straps.

To install tie-down strap:

1. Position straps over baggage. Thread straps through luggage handles if possible.
2. Clip hook ends of straps over loop fittings.
3. Grasp the buckle and pull the loose strap end of each strap to tighten straps over contents of baggage compartment.

To loosen tie-down straps:

1. Lift buckle release and pull on buckle to loosen strap.
2. Lift hook ends free of loop fittings.

Seats

The seating arrangement consists of two individually adjustable seats for the pilot and front seat passenger and two individual seats with fold down seat backs for the rear seat passengers.

The front seats are adjustable fore and aft and the seat backs can be reclined for passenger comfort or folded forward for rear seat access. Integral headrests are provided. The fore and aft travel path is

adjusted through the seat position control located below the forward edge of the seat cushion. The seat track is angled upward for forward travel so that shorter people will be positioned slightly higher as they adjust the seat forward. Recline position is controlled through levers located on each side of the seat backs. Depressing the recline release control while there is no pressure on the seat back will return the seat back to the full up position.

• **Caution** •

The seat bottoms have an integral aluminum honeycomb core designed to crush under impact to absorb downward loads. To avoid crushing this core, do not kneel or stand on the seats.

To position front seat fore and aft:

1. Lift the position control handle.
2. Slide the seat into position.
3. Release the handle and check that the seat is locked in place.

To adjust recline position:

1. Actuate and hold the seat back control lever.
2. Position the seat back to the desired angle.
3. Release the control lever.

Each rear seat consists of a fixed seat bottom, a folding seat back, and a headrest. The seat backs can be unlatched from inside the baggage compartment and folded forward to provide a semi-flat surface for bulky cargo extending forward from the baggage compartment.

To fold seat back forward:

1. From the baggage access, lift the carpet panel at lower aft edge of seat to reveal the seat back locking pins (attached to lanyards).
2. Remove the locking pins and fold seat forward.

Windshield and Windows

The windshield and side windows are manufactured of acrylic. Use only clean soft cloths and mild detergent to clean acrylic surfaces. *Refer to Section 8* for detailed cleaning instructions.

Cabin Safety Equipment

Passenger Restraints

Integrated seat belt and shoulder harness assemblies with inertia reels are provided for the pilot and each passenger. The rear seat belts are attached to fittings on the floorboard and the forward seat belts are attached to the seat frame. The shoulder harnesses are attached to inertia reels mounted in the seat back for the front seats and on the baggage compartment rear bulkhead for the rear seats. Each harness is attached to the seat belt. The buckle half of each assembly is on the left-hand side and the link half is on the right-hand side. The inertia reels allow complete freedom of movement of the occupant's upper torso. In the event of a sudden deceleration, the reels lock automatically to protect the occupants. It is recommended that the seat belts be stowed in the latched position when not in use.

Serials 0002 through 1499, 1501 through 1519 after SB 2X-25-14 and serials 1500, 1520 and subsequent; An inflatable shoulder harness is integral to each crew seat harness. The electronic module assembly, mounted below the cabin floor, contains a crash sensor, battery, and related circuitry to monitor the deceleration rate of the airplane. In the event of a crash, the sensor evaluates the crash pulse and sends a signal to an inflator assembly mounted to the aft seat frame. This signal releases the gas in the inflator and rapidly inflates the airbag within the shoulder harness cover. After airbag deployment, the airbag deflates to enable the pilot/co-pilot to egress the aircraft without obstruction.

The crash sensor's predetermined deployment threshold does not allow inadvertent deployment during normal operations, such as hard landings, strikes on the seat, or random vibration.

• Caution •

No slack may exist between the occupant's shoulder and restraint harness shoulder strap.

Stow the seat belts in the latched position when not in use.

To use the restraints:

1. Slip arms behind the harness so that the harness extends over shoulders.

2. Hold the buckle and firmly insert the link.
3. Grasp the seat belt tabs outboard of the link and buckle and pull to tighten. Buckle should be centered over hips for maximum comfort and safety.
4. Restraint harnesses should fit snug against the shoulder with the lap buckle centered and tightened around the hips.

To release the restraints:

1. Grasp the top of the buckle opposite the link and pull outward. The link will slip free of buckle.
2. Slip arms from behind the harness.

Emergency Egress Hammer

An eight-ounce ball-peen type hammer is located in the center armrest accessible to either front seat occupant. In the event of a mishap where the cabin doors are jammed or inoperable, the hammer may be used to break through the acrylic windows to provide an escape path for the cabin occupants.

Fire Extinguisher

A liquefied-gas-type fire extinguisher, containing Halon 1211/1301 extinguishing agent, is mounted on the forward inboard side of the pilot's seat base. The extinguisher is approved for use on class B (liquid, grease) and class C (electrical equipment) fires. The Halon 1211/1301 blend provides the best fire extinguishing capability with low toxicity. A pin is installed through the discharge mechanism to prevent inadvertent discharge of extinguishing agent. The fire extinguisher must be replaced after each use.

To operate the extinguisher:

1. Loosen retaining clamp and remove the extinguisher from its mounting bracket.
2. Hold the extinguisher upright and pull the pin.
3. Get back from the fire and aim nozzle at base of fire at the nearest edge.
4. Press red lever and sweep side to side.

• **WARNING** •

Halon gas used in the fire extinguisher can be toxic, especially in a closed area. After discharging fire extinguisher, ventilate cabin by opening air vents and unlatching door. Close vents and door after fumes clear.

The extinguisher must be visually inspected before each flight to assure that it is available, charged, and operable. The preflight inspection consists of ensuring that the nozzle is unobstructed, the pin has not been pulled, and the canister has not been damaged. Additionally, the unit should weigh approximately 1.5 lb (0.7 kg). For preflight, charge can be determined by 'hefting' the unit.

Engine

The SR22 is powered by a Teledyne Continental IO-550-N, six-cylinder, normally aspirated, fuel-injected engine rated to 310 hp at 2700 RPM. The engine has a 2000-hour Time Between Overhaul (TBO). Dual, conventional magnetos provide ignition.

Serials 0002 through 0819 before Service Bulletin SB 2X-71-06; The engine is attached to the firewall by a four-point steel engine mount.

Serials 0002 through 0819 after Service Bulletin SB 2X-71-06 and airplane serials 0820 and subsequent. The engine is attached to the firewall by a six-point steel engine mount.

The firewall attach points are structurally reinforced with gusset-type attachments that transfer thrust and bending loads into the fuselage shell.

Engine Oil System

The engine is provided with a wet-sump, high-pressure oil system for engine lubrication and cooling. Oil for engine lubrication is drawn from an eight-quart capacity sump through an oil suction strainer screen and directed through the oil filter to the engine-mounted oil cooler by a positive displacement oil pump. The oil pump is equipped with a pressure relief valve at the pump output end to bypass oil back to the pump inlet should the pump exceed limits. The oil cooler is equipped with a temperature control valve set to bypass oil if the temperature is below 180°F (82° C). Bypass or cooled oil is then directed through oil galleries to the engine rotating parts and piston inner domes. Oil is also directed to the propeller governor to regulate propeller pitch. The complete oil system is contained in the engine. An oil filler cap and dipstick are located at the left rear of the engine. The filler cap and dipstick are accessed through a door on the top left side of the engine cowling.

• Caution •

The engine should not be operated with less than six quarts of oil. Seven quarts (dipstick indication) is recommended for extended flights.

Engine Cooling

Engine cooling is accomplished by discharging heat to the oil and then to the air passing through the oil cooler, and by discharging heat directly to the air flowing past the engine. Cooling air enters the engine compartment through the two inlets in the cowling. Aluminum baffles direct the incoming air to the engine and over the engine cylinder cooling fins where the heat transfer takes place. The heated air exits the engine compartment through two vents in the aft portion of the cowling. No movable cowl flaps are used.

Engine Fuel Injection

The multi-nozzle, continuous-flow fuel injection system supplies fuel for engine operation. An engine driven fuel pump draws fuel from the selected wing tank and passes it to the mixture control valve integral to the pump. The mixture control valve proportions fuel in response to the pilot operated mixture control lever position. From the mixture control, fuel is routed to the fuel-metering valve on the air-induction system throttle body. The fuel-metering valve adjusts fuel flow in response to the pilot controlled Power Lever position. From the metering valve, fuel is directed to the fuel manifold valve (spider) and then to the individual injector nozzles. The system meters fuel flow in proportion to engine RPM, mixture setting, and throttle angle. Manual mixture control and idle cut-off are provided. An electric fuel pump provides fuel boost for vapor suppression and for priming.

Engine Air Induction System

Induction air enters the engine compartment through the two inlets in the forward cowling. The air passes through a dry-foam induction filter, through the throttle butterfly, into the six-tube engine manifold, and finally through the cylinder intake ports into the combustion chambers. Should the dry induction filter become clogged, a pilot controlled alternate induction air door can be opened, allowing engine operation to continue. *Refer to Engine Controls, Alternate Air Control.*

Engine Fuel Ignition

Two engine-driven magnetos and two spark plugs in each cylinder provide fuel ignition. The right magneto fires the lower right and upper left spark plugs, and the left magneto fires the lower left and upper

right spark plugs. Normal operation is conducted with both magnetos, as more complete burning of the fuel-air mixture occurs with dual ignition.

Engine Exhaust

Engine exhaust gases are routed through a tuned exhaust system. After leaving the cylinders, exhaust gases are routed through the exhaust manifold, through a muffler located on the right side of the engine or, *airplane serials 0320 and subsequent*, through mufflers located on either side of the engine, then overboard through an exhaust pipe(s) exiting through the lower cowling. A muff type heat exchanger, located around the right muffler, provides cabin heat.

Engine Controls

Engine controls are easily accessible to the pilot on a center console. They consist of a single-lever power (throttle) control and a mixture control lever. A friction control wheel, labeled FRICTION, on the right side of the console is used to adjust control lever resistance to rotation for feel and control setting stability. An alternate induction air source control is also provided.

Power (Throttle) Lever

The single-lever throttle control, labeled MAX-POWER-IDLE, on the console adjusts the engine throttle setting in addition to automatically adjusting propeller speed. The lever is mechanically linked by cables to the air throttle body/fuel-metering valve and to the propeller governor. Moving the lever towards MAX opens the air throttle butterfly and meters more fuel to the fuel manifold. A separate cable to the propeller governor adjusts the governor oil pressure to increase propeller pitch to maintain engine RPM. The system is set to maintain approximately 2500 RPM throughout the cruise power settings and 2700 RPM at full power.

Mixture Control

The mixture control lever, labeled RICH-MIXTURE-CUTOFF, on the console adjusts the proportion of fuel to air for combustion. The Mixture Control Lever is mechanically linked to the mixture control valve in the engine-driven fuel pump. Moving the lever forward (towards RICH) repositions the valve allowing greater proportions of fuel and moving the lever aft (towards CUTOFF) reduces (leans) the

proportion of fuel. The full aft position (CUTOFF) closes the control valve.

Start/Ignition Switch

• Note •

Airplane serials 0435 and subsequent with PFD: The Start/Ignition Switch is located on the instrument panel.

A rotary-type key switch, located on the left bolster, controls ignition and starter operation. The switch is labeled OFF-R-L- BOTH-START. In the OFF position, the starter is electrically isolated, the magnetos are grounded and will not operate. Normally, the engine is operated on both magnetos (switch in BOTH position) except for magneto checks and emergency operations. The R and L positions are used for individual magneto checks and for single magneto operation when required. When the battery master switch is ON, rotating the switch to the spring loaded START position energizes the starter and activates both magnetos. The switch automatically returns to the BOTH position when released.

Alternate Air Control

An Alternate Induction Air Control knob, labeled ALT AIR – PULL, is installed on the left console near the pilot's right ankle. To operate the control, depress the center lock button, pull the knob to the open position, and then release the lock button. Pulling the knob opens the alternate air induction door on the engine induction air manifold, bypasses the air filter, and allows warm unfiltered air to enter the engine. Alternate induction air should be used if blocking of the normal air source is suspected. Operation using alternate induction air should be minimized and the cause of filter blocking corrected as soon as practical.

Engine Indicating

The SR22 is equipped with engine instrumentation and warning lights to monitor the engine performance.

• Note •

For additional information on instrument limit markings, *refer to Section 2, Limitations.*

Serials 0002 through 1601, 1603 through 1643 and 1645 through 1662: The engine instruments are located on the right side of the instrument panel and the oil temperature/pressure warning light is located in the annunciator panel immediately in front of the pilot.

Serials 1602, 1644, 1663 and subsequent: The engine instrumentation is displayed on the MFD's Engine Page. A separate Data Acquisition Unit (DAU), mounted above the right hand kickplate, converts analog signals from the CHT, EGT, MAP, oil pressure, oil temperature, and tachometer sensors to digital format, which are then transmitted to the MFD and/or PFD for display. 28 VDC for Data Acquisition Unit operation is supplied through the 2-amp ANNUN / ENGINE INST circuit breaker on the Essential Bus

The PFD presents percent power in the upper left area of the display in vertical tape format and as text immediately above. Engine RPM, manifold pressure, fuel flow and oil pressure are continuously displayed in the engine data block located in the lower right corner of the PFD.

System health, caution, and warning messages are displayed in color-coded advisory boxes in the lower right corner of the MFD. In addition, the text of the engine parameters displayed on the PFD change to the corresponding color of advisory box during an annunciation event.

The oil temperature/pressure warning light is located in the annunciator panel immediately in front of the pilot.

• Note •

Serials 0002 and subsequent with optional EMax Engine Monitoring after factory installation or after Service Bulletin SB 22-77-01: The following engine instrument component descriptions are the same as those listed for airplane serials 1602, 1644, 1663 and subsequent except:

- EGT and CHT probes are installed to each exhaust pipe and cylinder head respectively. MFD functionality is enhanced by displaying six channels of EGT and CHT data.

Refer to Avidyne FlightMax EX5000C Pilot's Guide, for a more complete description of the MFD, its operating modes, and additional detailed operating procedures for the EMax option.

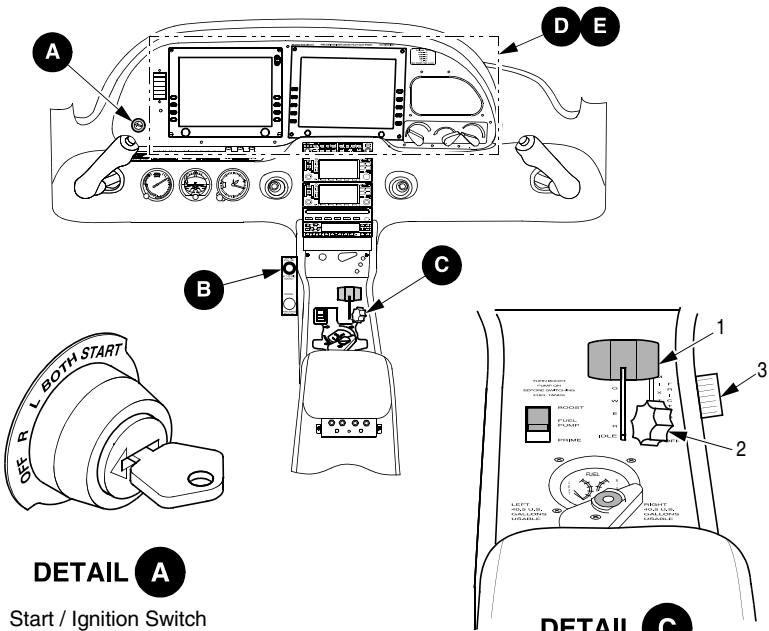

DETAIL A

Start / Ignition Switch

Serials 0002 thru 0434:
Switch is located on the left bolster panel.

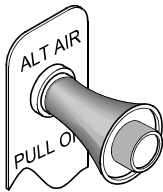

DETAIL B

Alternate Air Control

DETAIL C

Controls

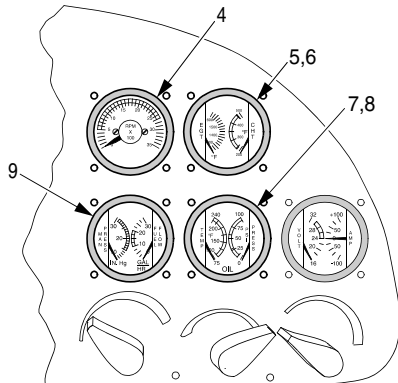

Serials 0002 thru 1601,
1603 thru 1643, 1645 thru 1662.

DETAIL D

Engine Instruments

LEGEND

- | | |
|---------------------|----------------------|
| 1. Power Lever | 6. CHT |
| 2. Mixture Control | 7. Oil Temperature |
| 3. Friction Control | 8. Oil Pressure |
| 4. Tachometer | 9. Manifold Pressure |
| 5. EGT | |

SR22_FM07_1603A

Figure 7-9
Engine Controls and Indicating (Sheet 1 of 2)

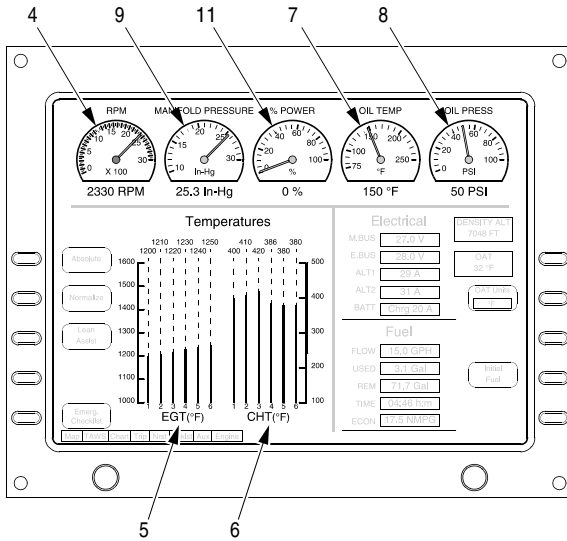
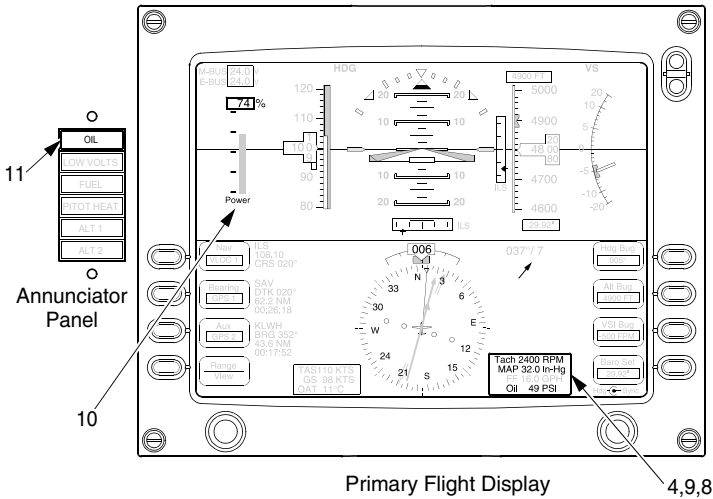

LEGEND

- 4. Tachometer
- 5. EGT (shown with EMax)
- 6. CHT (shown with EMax)
- 7. Oil Temperature
- 8. Oil Pressure
- 9. Manifold Pressure
- 10. Percent Power
- 11. Oil Warning Light

DETAIL E
Engine Instruments

Serials 1602, 1644, 1663 & subs.

SR22_FM07_2218

Figure 7-9
Engine Controls and Indicating (Sheet 2 of 2)

Tachometer

Serials 0002 through 1601, 1603 through 1643 and 1645 through 1662: A 2¼" tachometer is mounted on the right instrument panel adjacent to the other engine instruments. The tachometer pointer sweeps a scale marked from 0 to 3500 RPM in 100 RPM increments.

The electrically operated tachometer receives a speed signal from a magnetic pickup on the right hand magneto. 28 VDC for instrument operation is supplied through the 5-amp ENGINE INST circuit breaker on Main Bus 1.

Serials 1602, 1644, 1663 and subsequent: Engine RPM is shown in the upper left-most corner of the MFD as both a simulated tachometer and as text. The simulated tachometer receives a speed signal from a magnetic pickup on the right hand magneto via the DAU and sweeps a scale marked from 0 to 3000 RPM in 50 RPM increments.

Engine RPM is also continuously displayed in the engine data block located in the lower right corner of the PFD.

In the event engine speed exceeds 2710 RPM for five seconds, the MFD will display "Check RPM" in a red advisory box in the lower right corner of the MFD.

28 VDC for the digital instrument operation is supplied through the 2-amp ANNUN / ENGINE INST circuit breaker on the Essential Bus.

Exhaust Gas Temp / Cylinder Head Temp Gage/Bar Graphs

Serials 0002 through 1601, 1603 through 1643 and 1645 through 1662 without EMax Engine Monitoring: A 2¼" combination Exhaust Gas Temperature (EGT) and Cylinder Head Temperature (CHT) indicator is mounted in the right instrument panel. 28 VDC for instrument operation is supplied through the 5-amp ENGINE INST circuit breaker on Main Bus 1.

The EGT pointer sweeps a scale marked from 1250°F to 1650°F in 25°F increments. The EGT scale has no limit markings. The electrically operated EGT indicator receives a temperature signal from a thermocouple mounted in the exhaust stream of the #4 cylinder exhaust pipe. The CHT pointer sweeps a scale marked from 200°F to 500°F. The electrically operated CHT indicator receives a temperature

signal from a temperature sensor mounted in the #6 cylinder head on the left side of the engine.

Serials 1602, 1644, 1663 and subsequent: Exhaust Gas Temperature (EGT) and Cylinder Head Temperature (CHT) readings are displayed on the MFD as vertical bars that ascend and descend respective to increasing and decreasing temperatures.

The EGT indicator receives a temperature signal via the DAU from a sensor mounted in the exhaust stream of the #4 cylinder exhaust pipe. The EGT bar and graph is marked from 1000°F to 1600°F in 100°F increments. The EGT of the cylinder is displayed above the bar in text and an up or down trend arrow appears below the temperature to indicate whether EGT is rising or falling.

The CHT indicator receives a temperature signal via the DAU from a sensor mounted in the #6 cylinder head. The CHT bar and graph is marked from 100°F to 500°F in 100°F increments. The CHT of the cylinder is displayed above the bar in text and an up or down trend arrow appears below the temperature to indicate whether CHT is rising or falling.

In the event CHT exceeds 420°F, the MFD will display “Check CHT” in a yellow advisory box in the lower right corner of the MFD. In the event CHT exceeds 460°F, the MFD will display “Check CHT” in a red advisory box in the lower right corner of the MFD.

28 VDC for the digital instrument operation is supplied through the 2-amp ANNUN / ENGINE INST circuit breaker on the Essential Bus.

Oil Temperature / Oil Pressure Gage(s)

Serials 0002 through 1601, 1603 through 1643 and 1645 through 1662: A 2¼” combination Oil Temperature and Oil Pressure indicator is mounted on the right instrument panel below the EGT/CHT indicator. The instrument is internally lighted. 28 VDC for instrument operation is supplied through the 5-amp ENGINE INST circuit breaker on Main Bus 1.

The Oil Temperature pointer sweeps a scale marked from 50°F to 250°F in 25°F increments. The Oil Temperature indicator receives a temperature signal from a temperature sending unit mounted at the lower left side of the engine below the oil cooler.

The Oil Pressure pointer sweeps a scale marked from 0 psi to 100 psi. The Oil Pressure indicator receives a pressure signal from an oil pressure sensor mounted at the aft end of the engine below the oil cooler. Normally, oil pressure may drop to 10 psi at idle but will be in the 30 - 60 psi range at higher RPM.

Serials 1602, 1644, 1663 and subsequent: Oil temperature is shown in the upper right corner of the MFD as both a simulated temperature gage and as text. The simulated gage receives a temperature signal from a sensor mounted below the oil cooler via the DAU and sweeps a scale marked from 75°F to 250°F in 10°F increments.

In the event oil temperature reaches 235°F, the MFD will display "Monitor Oil Temperature" in a red advisory box in the lower right corner of the MFD.

In the event oil temperature exceeds 240°F, the MFD will display "Check Oil Temp" in a red advisory box in the lower right corner of the MFD.

Oil pressure is shown in the upper right-most corner of the MFD as both a simulated pressure gage and as text. The simulated gage receives a pressure signal from a sensor mounted below the oil cooler via the DAU and sweeps a scale marked from 0 psi to 100 psi in 5 psi increments.

Oil pressure is also continuously displayed in the engine data block located in the lower right corner of the PFD.

In the event oil pressure falls below 10 psi or exceeds 99 psi, the MFD will display "Check Oil Press" in a red advisory box in the lower right corner of the MFD.

In the event oil pressure falls below 30 psi or exceeds 75 psi, the MFD will display "Check Oil Press" in a yellow advisory box in the lower right corner of the MFD.

28 VDC for the digital instrument operation is supplied through the 2-amp ANNUN / ENGINE INST circuit breaker on the Essential Bus

Fuel Flow and/or Manifold Pressure Gage

Serials 0002 through 1601, 1603 through 1643 and 1645 through 1662: A 2¼" combination Fuel Flow and Manifold Pressure indicator is mounted on the right instrument panel immediately below the

tachometer. The indicator is internally lighted. 28 VDC for instrument operation is supplied through the 5-amp ENGINE INST circuit breaker on Main Bus #1.

The Fuel Flow pointer sweeps a scale marked from 0 to 30 Gal/Hr. The electrically operated Fuel Flow indicator receives a fuel-flow rate signal from a fuel-flow transducer on the right side of the engine in the fuel line between the engine driven fuel pump and throttle body metering valve.

The Manifold Pressure pointer sweeps a scale marked from 10 to 30 inches Hg in one-inch Hg increments. The electrically operated manifold pressure indicator receives a pressure signal from a pressure sensor mounted in the induction airstream on the left side of the induction air manifold near the throttle body.

Serials 1602, 1644, 1663 and subsequent: Manifold pressure is shown in the upper left corner of the MFD as both a simulated temperature gage and as text.

The simulated gage receives a pressure signal from a pressure sensor mounted in the induction air manifold near the throttle body via the DAU and sweeps a scale marked from 10 to 30 inches Hg in one-inch Hg increments.

Manifold pressure is also continuously displayed in the engine data block located in the lower right corner of the PFD.

28 VDC for the digital instrument operation is supplied through the 2-amp ANNUN / ENGINE INST circuit breaker on the Essential Bus.

Percent Power Gage

Serials 1602, 1644, 1663 and subsequent: Percent power is shown in the upper middle section of the MFD as both a simulated gage and as text.

The simulated gage displays calculated percent of maximum engine power produced by the engine based on an algorithm employing manifold pressure, indicated air speed, outside air temperature, pressure altitude, engine speed and fuel flow. The percent power gage sweeps a scale marked from 0 to 100 percent in 5 percent increments.

Percent power is also continuously displayed in the upper left area of the PFD in vertical tape format and as text immediately above.

28 VDC for the digital instrument operation is supplied through the 2-amp ANNUN / ENGINE INST circuit breaker on the Essential Bus.

Oil Warning Light

The red OIL warning light in the annunciator panel comes on to indicate either high oil temperature or low oil pressure. The light is illuminated by a switch in the oil temperature gage/DAU if the oil temperature reaches 240°F or if the oil pressure drops to 10 psi or less. If the OIL warning light comes on in flight, refer to the oil temperature and pressure gages to determine the cause. Typically, low oil pressure will be accompanied by a high oil temperature indication. The light is powered by 28 VDC through the 2-amp ANNUN / ENGINE INST circuit breaker on the Essential Bus.

Propeller

The airplane is equipped with a constant-speed, aluminum-alloy propeller with a three-blade (78" diameter) propeller and governor.

The propeller governor automatically adjusts propeller pitch to regulate propeller and engine RPM. The propeller governor senses engine speed by means of flyweights and senses throttle setting through a cable connected to the power (throttle) control lever in the cockpit. The propeller governor boosts oil pressure in order to regulate propeller pitch position. Moving the throttle lever forward causes the governor to meter less high-pressure oil to the propeller hub allowing centrifugal force acting on the blades to lower the propeller pitch for higher RPM operation. Reducing the power (throttle) lever position causes the governor to meter more high-pressure oil to the propeller hub forcing the blades to a higher pitch, lower RPM, position. During stabilized flight, the governor automatically adjusts propeller pitch in order to maintain an RPM setting (throttle position). Any change in airspeed or load on the propeller results in a change in propeller pitch.

Fuel System

An 81-gallon usable wet-wing fuel storage system provides fuel for engine operation. The system consists of a 42-gallon capacity (40.5-gallon usable) vented integral fuel tank and a fuel collector/sump in each wing, a three position selector valve, an electric boost pump, and an engine-driven fuel pump. Fuel is gravity fed from each tank to the associated collector sumps where the engine-driven fuel pump draws fuel through a filter and selector valve to pressure feed the engine fuel injection system. The electric boost pump is provided for engine priming and vapor suppression.

Each integral wing fuel tank has a filler cap in the upper surface of each wing for fuel servicing. Access panels in the lower surface of each wing allow access to the associated wet compartment (tank) for inspection and maintenance. Float-type fuel quantity sensors in each wing tank and each collector tank supply fuel level information to the fuel quantity indicators. Positive pressure in the tank is maintained through a vent line from each wing tank. Fuel, from each wing tank, gravity feeds through strainers and a flapper valve to the associated collector tank in each wing. Each collector tank/sump incorporates a flush mounted fuel drain and a vent to the associated fuel tank.

The engine-driven fuel pump pulls filtered fuel from the two collector tanks through a three-position (LEFT-RIGHT-OFF) selector valve. The selector valve allows tank selection. From the fuel pump, the fuel is proportioned to the induction airflow, metered to a flow divider, and delivered to the individual cylinders. Excess fuel is returned to the selected tank.

A dual-reading fuel-quantity indicator is located in the center console next to the fuel selector in plain view of the pilot. Fuel shutoff and tank selection is positioned nearby for easy access.

Fuel system venting is Essential to system operation. Blockage of the system will result in decreasing fuel flow and eventual engine fuel starvation and stoppage. Venting is accomplished independently from each tank by a vent line leading to a NACA-type vent mounted in an access panel underneath the wing near each wing tip.

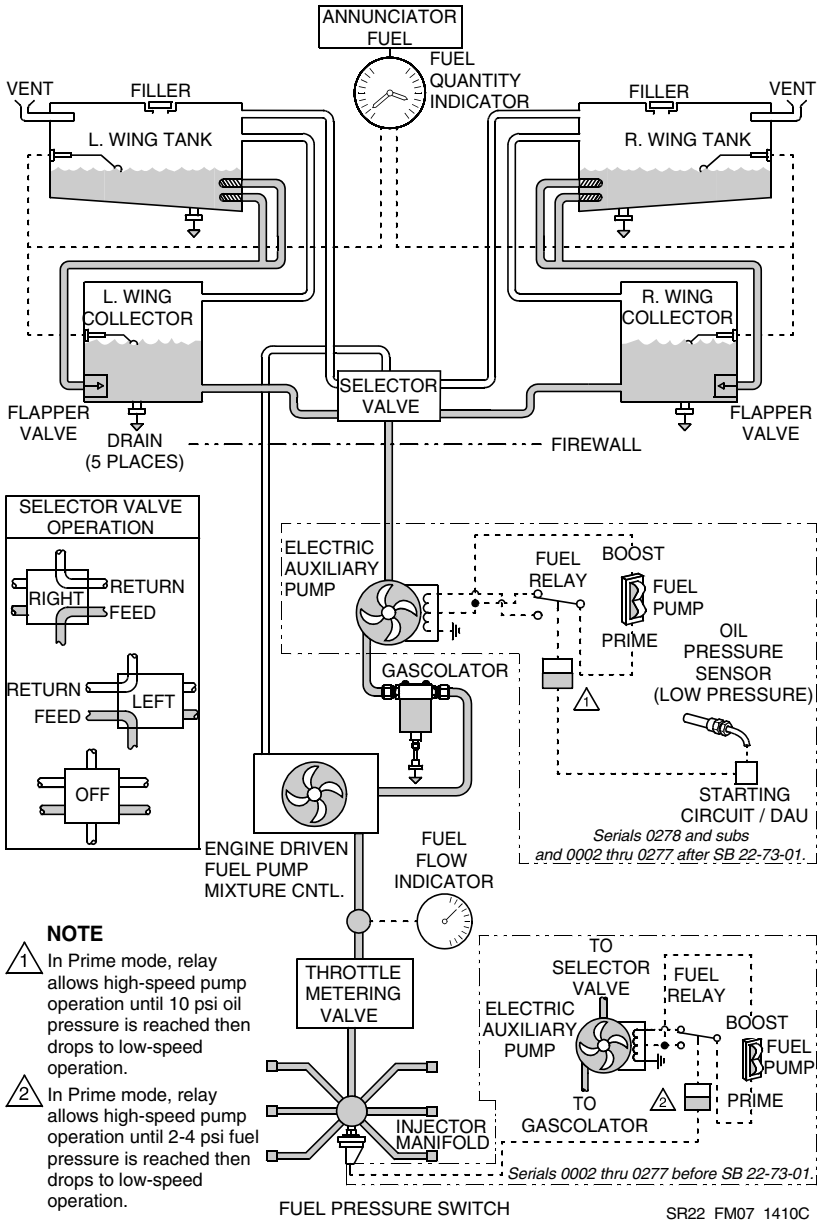

Figure 7-10
Fuel System Schematic

The airplane may be serviced to a reduced capacity to permit heavier cabin loadings. This is accomplished by filling each tank to a tab visible below the fuel filler, giving a reduced fuel load of 23.5 gallons usable in each tank (47 gallons total usable in all flight conditions).

Drain valves at the system low points allow draining the system for maintenance and for examination of fuel in the system for contamination and grade. The fuel must be sampled prior to each flight. A sampler cup is provided to drain a small amount of fuel from the wing tank drains, the collector tank drains, and the gascolator drain. If takeoff weight limitations for the next flight permit, the fuel tanks should be filled after each flight to prevent condensation.

• Note •

Serials 0002 and subsequent with optional EMax Engine Monitoring after factory installation or after Service Bulletin SB 22-77-01: The following fuel system component descriptions are the same as those listed for airplane serials 1602, 1644, 1663 and subsequent except:

- MFD functionality is enhanced by displaying fuel used, fuel remaining, time remaining, fuel economy, and the addition of Initial Usable Fuel page.

Refer to *Avidyne FlightMax EX5000C Pilot's Guide* for a more complete description of the MFD, its operating modes, and additional detailed operating procedures for the EMax option.

Fuel Selector Valve

A fuel selector valve, located at the rear of the center console, provides the following functions:

- LEFTAllows fuel to flow from the left tank
- RIGHT Allows fuel to flow from the right tank
- OFFCuts off fuel flow from both tanks

The valve is arranged so that to feed off a particular tank the valve should be pointed to the fuel indicator for that tank. To select RIGHT or LEFT, rotate the selector to the desired position. To select Off, first raise the fuel selector knob release and then rotate the knob to OFF.

Fuel Quantity Indicator

A dual reading 2¼" fuel quantity indicator is installed on the console immediately forward of the fuel selector valve. The LEFT pointer indicates left tank fuel quantity and sweeps a scale marked from 0 to 41 U.S. gallons in 5-gallon increments. The RIGHT pointer sweeps an identical scale for the right tank. Each scale is marked with a yellow arc from 0 to 14 U.S. gallons. The indicators are calibrated to read '0' when no usable fuel remains.

The FUEL annunciator also provides an output signal to illuminate the FUEL caution light when the fuel quantity is low. The fuel quantity indications are derived from float-type fuel-level sensors installed in each main tank and each collector tank. The indicator is internally lighted.

Serials 0002 through 1601, 1603 through 1643 and 1645 through 1662: 28 VDC for fuel quantity system operation is supplied through the 5-amp ENGINE INST circuit breaker on Main Bus 1. Serials 1602, 1644, 1663 and subsequent: 28 VDC for fuel quantity system operation is supplied through the 5-amp FUEL QTY / HOBBS circuit breaker on Main Bus 1.

• Note •

When the fuel tanks are 1/4 full or less, prolonged uncoordinated flight such as slips or skids can uncover the fuel tank outlets. Therefore, if operating with one fuel tank dry or if operating on LEFT or RIGHT tank when 1/4 full or less, do not allow the airplane to remain in uncoordinated flight for periods in excess of 30 seconds.

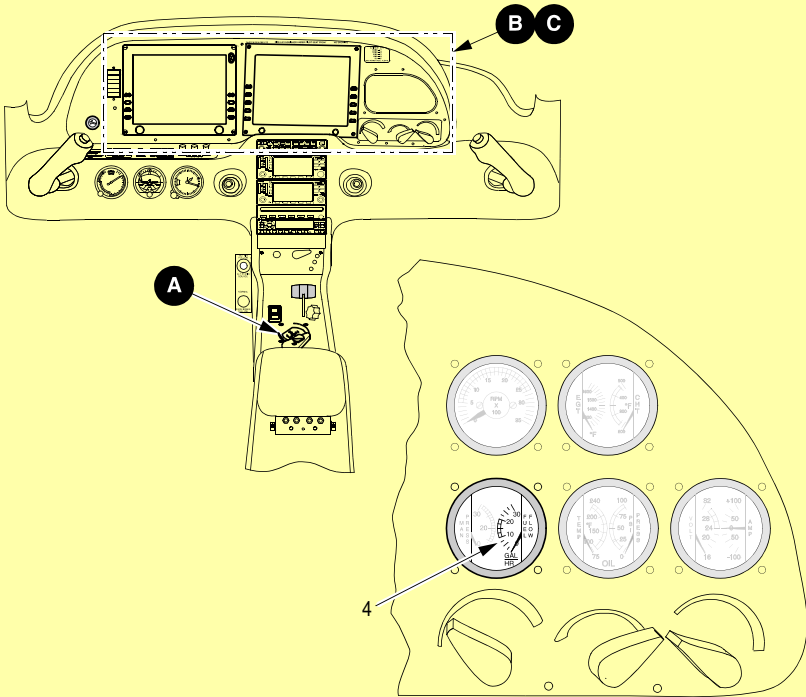

Serials 0002 thru 1601,
1603 thru 1643, 1645 thru 1662.

DETAIL B

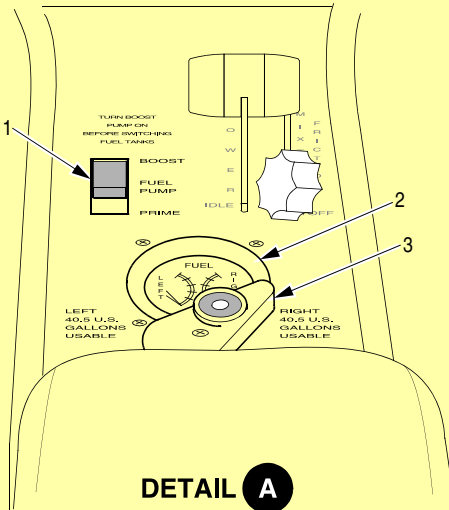

- LEGEND**
1. Fuel Pump Switch
 2. Fuel Quantity Gage
 3. Fuel Selector Valve
 4. Fuel Flow

SR22_FM07_2226

Figure 7-11
Fuel System Controls and Indicating (Sheet 1 of 2)

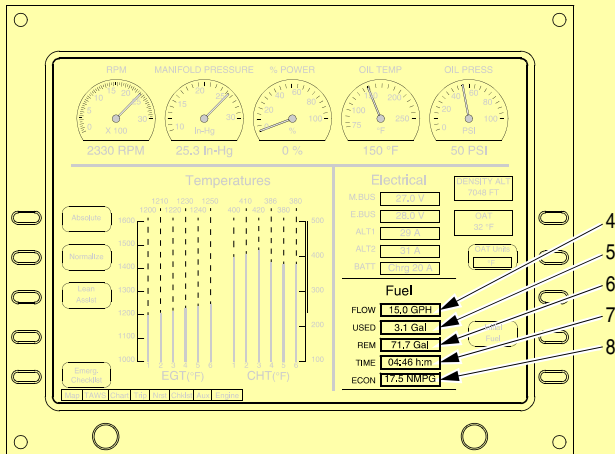
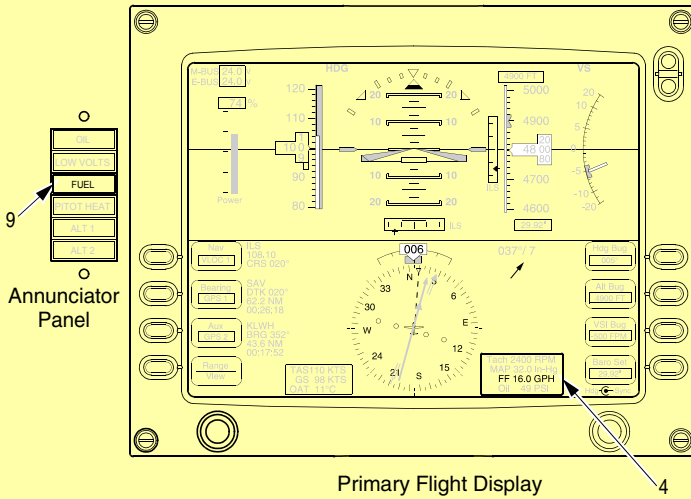

LEGEND

- 4. Fuel Flow
- 5. Fuel Used (EMax only)
- 6. Fuel Remaining (EMax only)
- 7. Time Remaining (EMax only)
- 8. Fuel Economy (EMax only)
- 9. Fuel Caution Light

DETAIL C

Serials 1602, 1644, 1663 & subs.

SR22_FM07_2228

Figure 7-11
Fuel System Controls and Indicating (Sheet 2 of 2)

Fuel Flow Indication

Serials 0002 through 1601, 1603 through 1643 and 1645 through 1662: Fuel flow indication is integral to the combination Fuel Flow/Manifold Pressure Gage. Refer to preceding discussion on Fuel Flow and Manifold Pressure Gage for complete description of fuel flow indication.

Serials 1602, 1644, 1663 and subsequent: Fuel flow is shown as text in the fuel data block located in the lower right section of the MFD and is also continuously displayed in the engine data block located in the lower right corner of the PFD. The MFD and PFD receives a fuel-flow rate signal via the DAU from a fuel-flow transducer on the right side of the engine in the fuel line between the engine driven fuel pump and throttle body metering valve.

In the event fuel flow exceeds 30.0 gallons per hour, the MFD will display "Check Fuel Flow" in a red advisory box in the lower right corner of the MFD.

28 VDC for the digital instrument operation is supplied through the 2-amp ANNUN / ENGINE INST circuit breaker on the Essential Bus.

Fuel Caution Light

The amber FUEL caution light in the annunciator panel comes on to indicate a low fuel condition.

If the FUEL caution light comes on in flight, refer to the Fuel Quantity gages to determine fuel quantity. The light is powered by 28 VDC through the 2-amp ANNUN / ENGINE INST circuit breaker on the Essential Bus.

Boost Pump Switch

Boost pump operation and engine prime is controlled through the Fuel Pump BOOST-PRIME switch located adjacent to the fuel selector valve. The PRIME position is momentary and the BOOST position is selectable. A two-speed prime allows the fuel pressure to rapidly achieve proper starting pressure.

Serials 0002 through 0277 before SB 22-73-01: For engine starting, pressing PRIME causes the boost pump to operate at high speed until the fuel pressure reaches 2-4 psi. When the fuel pressure reaches the 2-4 psi range, a pressure switch in the fuel injection line switches the boost pump to the low-speed mode to provide a 4-6 psi fuel pressure boost. Selecting BOOST energizes the boost pump in low-speed mode to deliver a continuous 4-6 psi boost to the fuel flow for vapor suppression in a hot fuel condition.

Serials 0278 and subs, and serials 0002 through 0277 after SB 22-73-01: An oil pressure based system is used to control boost pump operation. The oil pressure/oil temperature sensor provides a signal to the starting circuit/DAU to generate a ground for the oil annunciator and the fuel system. This system allows the fuel pump to run at high speed (PRIME) when the engine oil pressure is less than 10 PSI. Whenever the engine oil pressure exceeds 10 PSI, pressing PRIME will have no effect. Selecting BOOST energizes the boost pump in low-speed mode regardless of oil pressure to deliver a continuous 4-6 psi boost to the fuel flow for vapor suppression in a hot fuel condition.

The boost pump operates on 28 VDC supplied through the 5-amp FUEL PUMP circuit breaker on Main Bus 2.

Brake System

The main wheels have hydraulically operated, single-disc type brakes, individually activated by floor mounted toe pedals at both pilot stations. A parking brake mechanism holds induced hydraulic pressure on the disc brakes for parking.

The brake system consists of a master cylinder for each rudder pedal, a hydraulic fluid reservoir, a parking brake valve, a single disc brake assembly on each main landing gear wheel, and associated hydraulic plumbing. Braking pressure is initiated by depressing the top half of a rudder pedal (toe brake). The brakes are plumbed so that depressing either the pilot's or copilot's left or right toe brake will apply the respective (left or right) main wheel brake. The reservoir is serviced with Mil-H-5606 hydraulic fluid.

Brake system malfunction or impending brake failure may be indicated by a gradual decrease in braking action after brake application, noisy or dragging brakes, soft or spongy pedals, excessive travel, and/or weak braking action. Should any of these symptoms occur, immediate maintenance is required. If, during taxi or landing roll, braking action decreases, let up on the toe brakes and then reapply the brakes with heavy pressure. If the brakes are spongy or pedal travel increases, pumping the pedals may build braking pressure.

Refer to Section 10, Safety Information, for Brake System operational considerations.

Parking Brake

• Caution •

Do not pull the PARK BRAKE knob in flight. If a landing is made with the parking brake valve set, the brakes will maintain any pressure applied after touchdown.

The main wheel brakes are set for parking by using the PARK BRAKE knob on the left side of the console near the pilot's right ankle. Brake lines from the toe brakes to the main wheel brake calipers are plumbed through a parking brake valve. For normal operation, the knob is pushed in. With the knob pushed in, poppets in the valve are mechanically held open allowing normal brake operation. When the handle is pulled out, the parking brake valve holds applied brake pressure, locking the brakes. To apply the parking brake, set the brakes with the rudder-pedal toe brakes, and then pull the PARK BRAKE knob aft.

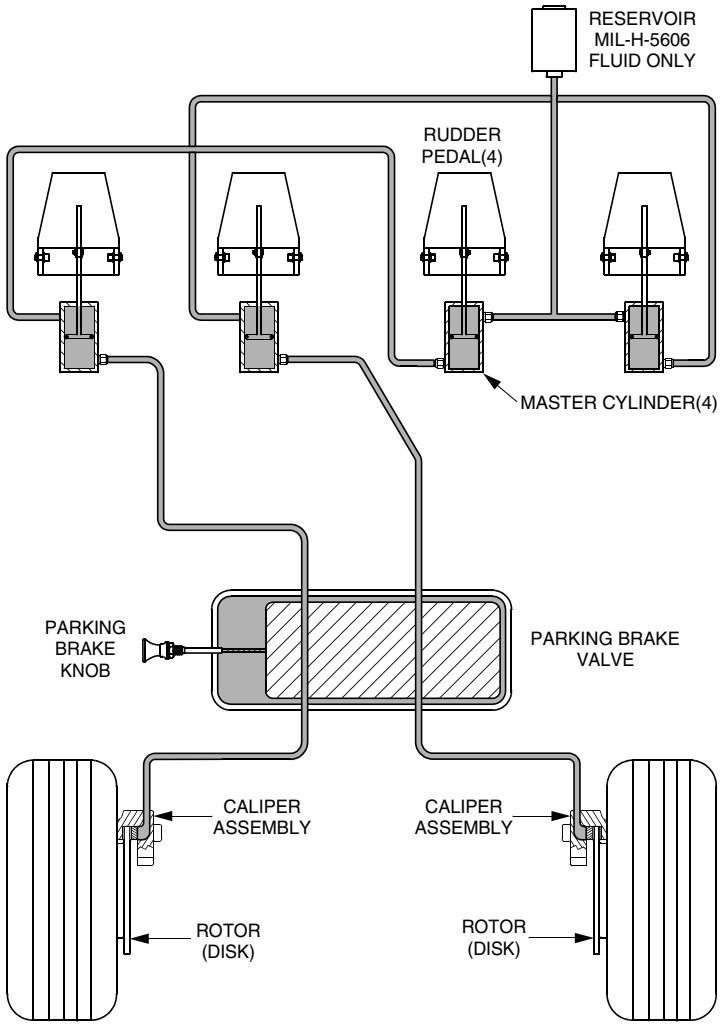

SR22_FM07_1015

Figure 7-12
Brake System

Electrical System

The airplane is equipped with a two-alternator, two-battery, 28-volt direct current (VDC) electrical system designed to reduce the risk of electrical system faults. The system provides uninterrupted power for avionics, flight instrumentation, lighting, and other electrically operated and controlled systems during normal operation.

Power Generation

Primary power for the SR22 is supplied by a 28-VDC, negative-ground electrical system. The electrical power generation system consists of two alternators controlled by a Master Control Unit (MCU) mounted on the left side of the firewall and two batteries for starting and electrical power storage.

Alternator 1 (ALT 1) is a gear-driven, internally rectified, 60-amp alternator mounted on the right front of the engine. Alternator 2 (ALT 2) is a gear-driven, internally rectified, 20-amp alternator mounted on the accessory drive at the rear of the engine. ALT 1 is regulated to 28 volts and ALT 2 is regulated to 28.75 volts. The output from ALT 1 is connected to the Main Distribution Bus in the MCU through an 80-amp fuse. The output from ALT 2 is connected to the Essential Distribution Bus in the MCU through a 40-amp fuse. Both alternators are self-exciting (not self-starting) and require battery voltage for field excitation in order to start up - for this reason, the batteries should not be turned off in flight.

Battery 1 (BAT 1) is an aviation grade 12-cell, lead-acid, 24-volt, 10-amp-hour battery mounted on the right firewall. BAT 1 is charged from the Main Distribution Bus in the MCU. Battery 2 (BAT 2) is composed of two 12-volt, 7-amp-hour, sealed, lead-acid batteries connected in series to provide 24 volts. Both BAT 2 units are located in a vented, acid-resistant container mounted behind the aft cabin bulkhead (FS 222) below the parachute canister. BAT 2 is charged from the circuit breaker panel Essential Bus.

The Master Control Unit (MCU) is located on the left firewall. The MCU controls ALT 1, ALT 2, starter, landing light, external power, and power generation functions. In addition to ALT 1 and ALT 2 voltage regulation, the MCU also provides external power reverse polarity protection, alternator overvoltage protection, as well as alternator fail

and overcurrent annunciations. Power is distributed to the airplane circuit panel buses through Main and Essential buses in the MCU. During normal operation, the alternators feed their respective Distribution Bus independently (ALT 1 feeds Main Distribution Bus and ALT 2 feeds the Essential Distribution Bus). The distribution busses are interconnected by two 50-amp fuses and a diode. The diode prevents ALT 2 from feeding the Main Distribution Bus. Additionally, since ALT 2 / Essential Distribution Bus voltage is slightly higher than ALT 1 / Main Distribution Bus voltage, ALT 1 will not feed the Essential Distribution Bus unless ALT 2 fails.

Power Distribution

The power distribution system for the SR22 consists of the Main Distribution Bus and the Essential Distribution Bus in the MCU and associated buses in the Circuit Breaker panel. The circuit breaker panel is located on the left side of the console next to the pilots right knee.

For normal operation, the Essential Buses in the circuit breaker panel are powered from the Essential Distribution Bus in the MCU through 25-amp circuit breakers. BAT 2 is connected directly to the Essential Bus in the circuit breaker panel and will power the bus should the voltage coming from the MCU distribution buses drop below the battery voltage. Additionally, in the event of an ALT 2 failure, the circuit breaker panel Essential Bus will be powered from ALT 1 through the Main distribution and Essential distribution buses in the MCU. Main Bus 1, Main Bus 2, and the equipment Non-Essential Bus in the circuit breaker panel are powered from ALT 1 through the Main Distribution Bus in the MCU. The Avionics Non-Essential Bus in the circuit breaker panel is powered from Main Bus 1.

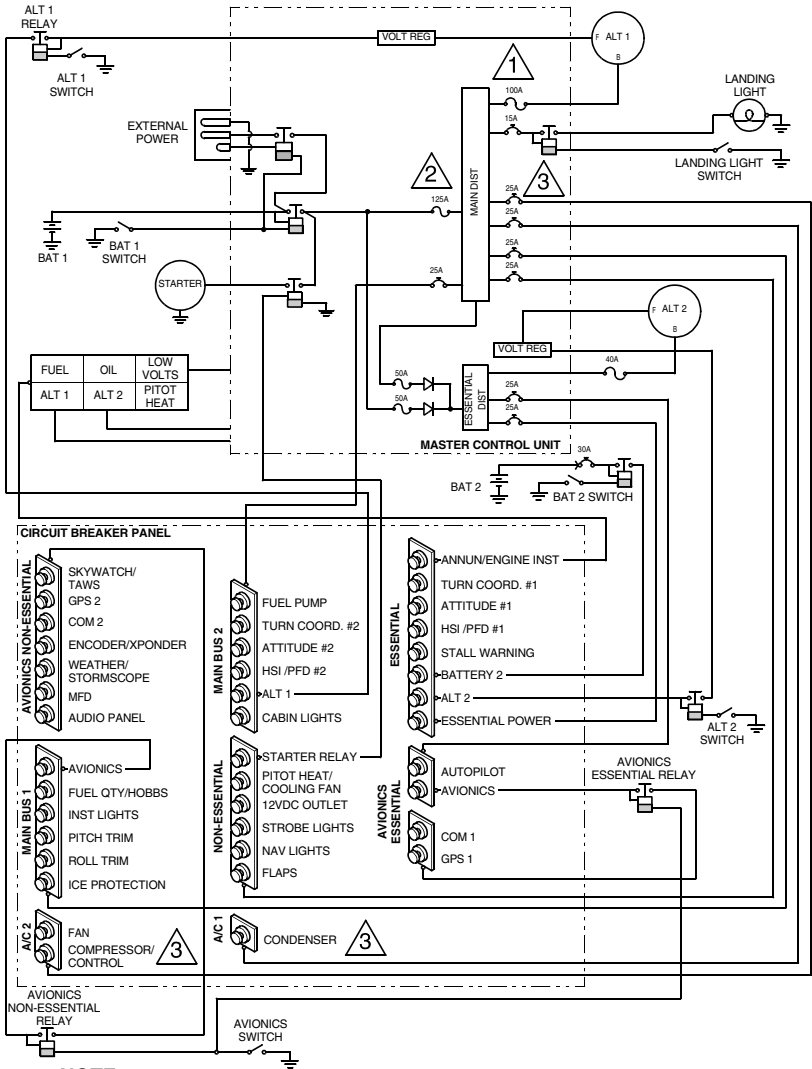

NOTE

- 1 Serials 0002 thru 1601, 1603 thru 1643 and 1645 thru 1662: 80A fuse.
- 2 Serials 0002 thru 1601, 1603 thru 1643 and 1645 thru 1662: 100A fuse.
- 3 Serials 1602, 1821, 1840, 1863 & subs with optional Air Conditioning system installed.

SR22_FM07_1458G

Figure 7-13
Electrical System Schematic

BAT & ALT Master Switches

The rocker type electrical system MASTER switches are ON in the up position and OFF in the down position. The switches, labeled BAT 2, BAT 1, ALT 1, ALT 2 are located in the bolster switch panel immediately below the instrument panel. These switches, along with the AVIONICS power switch, control all electrical power to the airplane.

Battery Switches

The BAT 1 and BAT 2 switches control the respective battery. Setting the BAT 1 switch 'on' energizes a relay connecting BAT 1 to the MCU Distribution Buses (also energizing the circuit breaker panel buses) and the open contacts of the starter relay. Setting the BAT 2 switch 'on' energizes a relay connecting BAT 2 to the circuit breaker panel Essential Buses. Normally, for flight operations, all master switches will be 'on.' However, the BAT 1 and BAT 2 switches can be turned 'on' separately to check equipment while on the ground. Setting only the BAT 2 switch 'on' will energize those systems connected to the circuit breaker panel Essential Bus. If any system on the other buses is energized, a failure of the Distribution Bus interconnect isolation diode is indicated. When the BAT 1 switch is set to 'on,' the remaining systems will be energized. To check or use avionics equipment or radios while on the ground, the AVIONICS power switch must also be turned on.

Alternator Switches

The ALT 1 and ALT 2 switches control field power to the respective alternator. For ALT 1 to start, the BAT 1 switch must be 'on.' Setting the ALT 1 switch 'on' energizes a relay allowing 28 VDC from the ALT 1 circuit breaker (Main Bus 2) to be applied to voltage regulator for ALT 1. For ALT 2 to start, either the BAT 1 switch or the BAT 2 switch must be 'on.' Setting the ALT 2 switch 'on' energizes a relay allowing 28 VDC from the ALT 2 circuit breaker (Essential Bus) to be applied to voltage regulator for ALT 2. Positioning either ALT switch to the OFF position removes the affected alternator from the electrical system.

• Note •

Continued operation with the alternators switched off will reduce battery power low enough to open the battery relay, remove power from the alternator field, and prevent alternator restart.

Avionics Power Switch

A rocker switch, labeled AVIONICS, controls electrical power from the circuit breaker panel bus to the Avionics Bus. The switch is located next to the ALT and BAT Master switches. Typically, the switch is used to energize or de-energize all avionics on the Avionics Non-Essential and Essential Buses simultaneously. With the switch in the OFF position, no electrical power will be applied to the avionics equipment, regardless of the position of the master switch or the individual equipment switches. For normal operations, the AVIONICS switch should be placed in the OFF position prior to activating the MASTER switches, starting the engine, or applying an external power source.

Volts and Ampere Meter/Indication

Serials 0002 through 1601, 1603 through 1643 and 1645 through 1662: A 2¼" combination Volts and Ampere meter is mounted on the right instrument panel outboard of the oil temperature and pressure indicator. The indicator is internally lighted. 28 VDC for instrument lighting is supplied through the 2-amp INST LIGHTS circuit breaker on Main Bus 1.

The VOLT pointer sweeps a scale from 16 to 32 volts. *Refer to Section 2, Limitations,* in basic POH for instrument limit markings. The voltage indication is measured off the Essential Bus.

The AMP pointer sweeps a scale from -100 to +100 amps with zero at the 9 o'clock position. The amps indication is derived from current transducers located in the MCU. Output from each alternator and BAT 1 is measured. The panel mounted AMMETER SELECT switch is used to select the desired indication. When the engine is operating and the ALT 1 and ALT 2 Master switches are 'on,' the ammeter indicates the charging rate applied to the batteries. In the event the alternators are not functioning or the electrical load exceeds the output of the alternators, the ammeter indicates BAT 1 discharge rate. Alternator ammeter indications are positive only.

Serials 1602, 1644, 1663 and subsequent: Main and Essential Bus voltages are shown as text in the electrical data block located in the mid-right section of the MFD and are also displayed in the voltage parameters block located in the upper left corner of the PFD when voltages fall outside typical operating parameters. The MFD and PFD receive the voltage signals via the DAU as measured directly off the Main and Essential Buses.

In the event Main Bus voltage is less than 24.5v or exceeds 32.0v the MFD will display "Check Main Bus" in a yellow advisory box in the lower right corner of the MFD.

In the event Essential Bus voltage is less than 24.5v or exceeds 32.0v the MFD will display "Check Main Bus" in a red advisory box in the lower right corner of the MFD.

Alternator 1 and Alternator 2 ampere output are shown as text in the electrical data block located in the mid-right section of the MFD. The MFD and PFD receive the amp signals via the DAU as derived from current transducers located in the MCU.

In the event Alternator 1 or Alternator 2 ampere output is less than 2 amps for 20 seconds or more, the MFD will display "Check ALT 1" or "Check ALT 2" respectively, in a yellow advisory box in the lower right corner of the MFD.

28 VDC for the digital instrument operation is supplied through the 2-amp ANNUN / ENGINE INST circuit breaker on the Essential Bus.

Ammeter Select Switch

Serials 0002 through 1601, 1603 through 1643 and 1645 through 1662: The AMMETER SELECT switch on the instrument panel is used to select the desired source of electrical current flow to be indicated on the ammeter. The switch has three positions: ALT 1, BATT, and ALT 2. The BATT position indicates BAT 1 current flow only. Selecting one of the switch positions will cause the amperage output from that device to be displayed on the ammeter.

Serials 1602, 1644, 1663 and subsequent: Main and Essential Bus voltages are displayed on the MFD and PFD, therefore, no ammeter select switch is necessary.

Low-Volts Warning Light

The airplane is equipped with a red LOW VOLTS warning light in the annunciator panel located on the left side of the instrument panel. A voltage sensor in the (MCU) monitors voltage on the Essential Bus and illuminates the warning light when the voltage is less than approximately 24.5 volts.

• Note •

The LOW VOLTS warning light may come on during extended low RPM operation with heavy electrical loads. Under these conditions, the light will go out at higher RPM.

ALT Fail Caution Lights

Two ALT Fail caution lights are installed in the annunciator panel. The ALT 1 and ALT 2 caution lights in the annunciator panel provide annunciation of alternator failure or overcurrent conditions at the respective alternator. The lights are operated by circuits in the MCU and current sensors on the ALT 1 and ALT 2 output lines. Steady illumination of either light indicates an alternator failure. *Serials 0002 through 1601, 1603 through 1643 and 1645 through 1662:* A flashing ALT light indicates an overcurrent condition.

Circuit Breakers and Fuses

Individual electrical circuits connected to the Main, Essential, and Non-Essential Buses in the airplane are protected by re-settable circuit breakers mounted in the circuit breaker panel on the left side of the center console.

Essential Buses

The circuit breaker panel Essential Bus is powered by ALT 2 from the MCU Essential Distribution Bus through the 25-amp ESSENTIAL POWER circuit breaker and from BAT 2 through the 30-amp BATTERY 2 circuit breaker. The Essential Bus is also powered by ALT 1 and BAT 1 through an isolation diode connecting the Main and Essential Distribution Buses in the MCU. The autopilot and Essential avionics equipment are powered directly from the Essential Distribution Bus in the MCU through a 25-amp circuit breaker on the Distribution Bus. Power from the 15-amp AVIONICS circuit breaker is also controlled through the AVIONICS master switch on the bolster switch panel.

Main Buses

The circuit breaker panel Main Bus 1 and Main Bus 2 are powered by ALT 1 and BAT 1 from the MCU Main Distribution Bus through 25-amp circuit breakers on the Distribution Bus. ALT 2 and BAT 2 are prevented from powering the Main Buses by the isolation diode interconnecting the MCU distribution buses. Loads on circuit breaker panel Main Buses are shed by pulling the individual circuit breakers. The 15-amp AVIONICS circuit breaker on Main Bus 1 powers all loads on the Non-Essential Avionics Bus. Power from the 15-amp AVIONICS circuit breaker is also controlled through the AVIONICS master switch on the bolster switch panel.

Non-Essential Buses

The circuit breaker panel contains two Non-Essential Buses, the Non-Essential Equipment Bus and the Avionics Non-Essential Bus. The Avionics Non-Essential Bus is powered through the 15-amp AVIONICS circuit breaker on Main Bus 1 and is discussed above. The Non-Essential Equipment Bus is powered by ALT 1 and BAT 1 from the MCU Main Distribution Bus through a 25-amp circuit breaker. ALT 2 and BAT 2 are prevented from powering the Non-Essential Equipment Bus by the isolation diode interconnecting the MCU

distribution buses. Loads on the Non-Essential Equipment Bus are shed by pulling the individual circuit breakers.

Ground Service Receptacle

A ground service receptacle is located just aft of the cowl on the left side of the airplane. This receptacle is installed to permit the use of an external power source for cold weather starting and maintenance procedures requiring reliable power for an extended period. The external power source must be regulated to 28 VDC. The external power control contactor is wired through the BAT 1 MASTER switch so that the BAT 1 switch must be 'on' to apply external power.

Refer to Section 8, Ground Handling, Servicing, and Maintenance, for use of external power and special precautions to be followed.

Convenience Outlet

A 12-volt convenience outlet is installed in the center console. The receptacle accepts a standard cigarette-lighter plug. The outlet may be used to power portable entertainment equipment such as CD players, cassette players, and portable radios. Amperage draw through the outlet must not exceed 3.5 amps. Power for the convenience outlet is supplied through the 5-amp 12VDC OUTLET circuit breaker on the Non-Essential Bus.

Exterior Lighting

The airplane is equipped with standard wing tip navigation lights with integral anti-collision strobe lights. and Serials 1863 & subs; recognition lights. The separately controlled landing light is located in the lower cowl..

Navigation Lights

The airplane is equipped with standard wing tip navigation lights. The lights are controlled through the NAV light switch on the instrument panel bolster. 28 VDC for navigation light operation is supplied through the 5-amp NAV LIGHTS circuit breaker on Non-Essential Bus.

Strobe Light

Anti-collision strobe lights are installed integral with the standard navigation lights. Each strobe is flashed by a separate power supply. The strobe power supplies are controlled through the STROBE light switch on the instrument panel bolster. 28 VDC for strobe light and control circuits is supplied through the 5-amp STROBE LIGHTS circuit breaker on Non-Essential Bus.

Landing Light

A High Intensity Discharge (HID) landing light is mounted in the lower engine cowl. The landing light is controlled through the LAND light switch on the instrument panel bolster.

Setting the LAND light switch 'ON' energizes the landing light control relay in the Master Control Unit (MCU) completing a 28 VDC circuit from the airplane Main Distribution Bus to the light's ballast located on the firewall. The ballast provides boosted voltage to illuminate the HID lamp. A 15-amp breaker on the Main Distribution Bus in the MCU protects the circuit.

Recognition Lights (Optional) - Serials 1863 and subs

The airplane is equipped with recognition lights on the leading edge of the wing tips. The lights are controlled through the landing light switch on the instrument panel bolster. 28 VDC for recognition light operation is supplied through the 5-amp REC/INST LTS circuit breaker on Main Bus 1.

Interior Lighting

Interior lighting for the airplane consists of separately controlled incandescent overhead lights for general cabin lighting, individual lights for the pilots and passengers, and dimmable panel floodlights. The flight instrumentation and avionics equipment lights are dimmable.

Instrument Lights

Instrument lighting for the airplane consists of dimmable incandescent lights in the instrument bezels. The lights are controlled through the INST lights control on the instrument panel bolster. Rotating the knob clockwise energizes the lights and increases brightness. The instrument light circuits operate on 28 VDC supplied through the 2-amp INST LIGHTS circuit breaker on Main Bus 1.

Panel Flood Lights

A string of red LEDs mounted under the instrument panel glareshield provide flood lighting for the instrument panel. The lights are controlled through the PANEL lights control on the instrument panel bolster. Rotating the knob clockwise energizes the lights and increases brightness. The panel lights operate on 28 VDC supplied through the 3-amp CABIN LIGHTS circuit breaker on Main Bus 2.

Reading Lights

Individual eyeball-type reading lights are installed in the headliner above each passenger position. Each light is aimed by positioning the lens in the socket and is controlled by a push-button switch located next to the light. The pilot and copilot reading lights are also dimmable through the PANEL lights control on the instrument panel bolster. The lights are powered by 28 VDC supplied through the 3-amp CABIN LIGHTS circuit breaker on Main Bus 2.

Overhead Dome Light

General cabin lighting is provided by a dome light located in the headliner at the approximate center of the cabin. The dome light is controlled through the OVERHEAD light control on the instrument panel bolster. Rotating the knob clockwise from the off position will illuminate the light and control its intensity. The lights are powered by 28 VDC supplied through the 3-amp CABIN LIGHTS circuit breaker on Main Bus 2.

Environmental System

Cabin heating and ventilation is accomplished by supplying conditioned air for heating and windshield defrost and fresh air for ventilation. Ventilation air is provided by ducting ram air from air inlets to eyeball outlets for each occupant. Each occupant can direct the fresh air flow by positioning the nozzle or control flow rate from 'off' to maximum by rotating the nozzle.

Heating is accomplished by mixing ram air from the fresh air inlets with heated air from the heat exchanger and then distributing the 'conditioned' air to the occupants and/or the windshield diffuser. Air for heating is supplied by an inlet in the engine compartment to a muff-type heat exchanger surrounding the right engine exhaust muffler.

Conditioned air outlets for the forward occupants are directionally controllable and are located beneath the instrument panel at each position at knee level. Outlets for the rear occupants are at floor level.

The temperature, volume, and flow selection are regulated by manipulation of the cabin temperature and cabin air selector knobs on the lower right side of the instrument panel.

Serials 1602, 1821, 1840, 1863 and subsequent: An optional blower fan and/or air conditioning system is available

Description and Operation

Serials 0002 thru 1601, 1603 thru 1820, 1822 thru 1839, 1841 thru 1862*

The environmental system consists of an air inlet in the upper RH cowl, a heat exchanger around the RH engine exhaust muffler, two fresh air inlets, located in each wing root leading edge, a hot air valve located on the firewall, an air mixing plenum located behind the instrument panel, a windshield diffuser, air ducting for distribution, crew and passenger air vents, and required actuators for selecting temperature and flow

Cabin Air Selector

“Conditioned” air from the mixing plenum can be proportioned and directed to the windshield or passengers by manipulating the cabin air selector. The control is linked to a door at the outlet end of the mixing plenum. Rotating the control full counterclockwise shuts off airflow to

the passenger air distribution system and allows maximum airflow to the windshield diffuser. Rotating the knob full clockwise shuts off airflow to the windshield diffuser and allows maximum airflow to the passenger air distribution system. The control can be positioned to allow any proportion of windshield and passenger air. Conditioned air for the forward seats is routed to outlets under the instrument panel at knee level. Conditioned air for the aft seats is routed to outlets beneath the forward seats near the door posts and exits at floor level.

Cabin Heat Control

The amount of heated air allowed into the air mixing plenum is controlled by rotating the Cabin Heat Control. The control is mechanically linked to a door in a heater box between the heater muff and the mixing plenum. Rotating the control full counterclockwise (HEAT OFF) bypasses heated air from the heater muff into the engine compartment. Rotating the control clockwise opens the door in the heater box allowing heated air to enter the mixing plenum.

Cabin Cooling Control

The amount of cooling air allowed into the air mixing plenum is controlled by rotating the cabin cool control, located outboard of the cabin air selector. The control is mechanically linked to a butterfly valve at the fresh air entrance to the mixing plenum. Rotating the control full counterclockwise shuts down cooling airflow to the mixing plenum from the fresh air inlet in the right wing root. Rotating the control clockwise opens the butterfly allowing fresh cooling air to enter the mixing plenum. Rotating the knob to the full clockwise (COLD) position provides maximum cooling airflow to the mixing plenum.

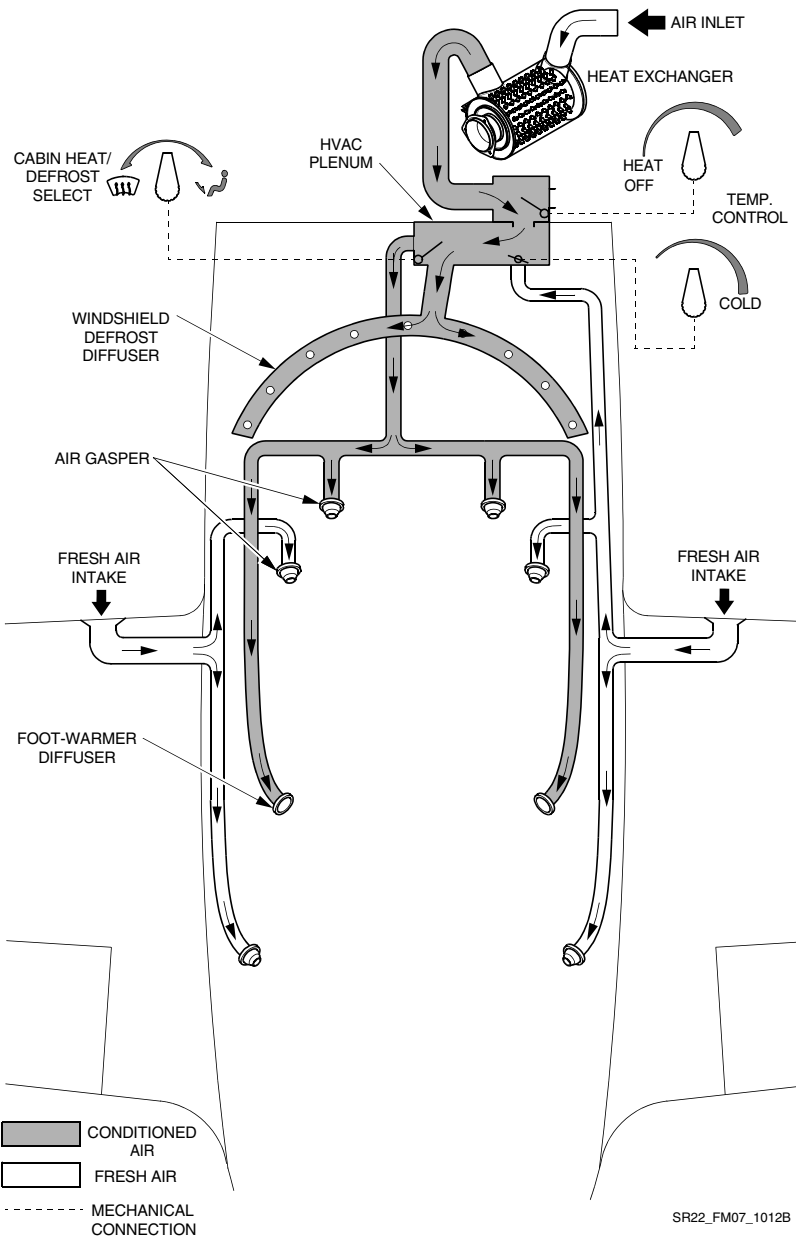

Figure 7-14
Cabin Heating and Cooling - Serials 0002 thru 1862*
P/N 13772-001
Revision A10

Serials 1602, 1821, 1840, 1863 and subsequent*

Serials 1602, 1821, 1840, 1863 thru 2437: The environmental system consists of a fresh air inlet in the RH upper cowl, a heat exchanger around the RH engine exhaust muffler, one fresh air inlet located in the RH wing root leading edge, a hot air valve located on the firewall, an air mixing chamber located under the RH crew seat, a distribution manifold behind the instrument pannel, a windshield diffuser, air ducting for distribution, crew and passenger air vents, and required actuators for selecting temperature and flow.

Serials 2438 and subs: The environmental system consists of a fresh air inlet in the RH upper cowl, a heat exchanger around the RH engine exhaust muffler, a fresh air inlet in the RH lower cowl, an air mixing chamber located on the firewall, a distribution manifold behind the instrument pannel, a windshield diffuser, air ducting for distribution, crew and passenger air vents, and required actuators for selecting temperature and flow.

28 VDC for Environmental System Control Panel operation is supplied through the 5-amp COMP/CTRL breaker on A/C BUS 2.

An optional 3-speed blower fan is available to supplement airflow when ram air may be inadequate such as during ground operation. The optional Blower Fan is powered by 28 VDC supplied through a 15-amp FAN breaker on A/C BUS 2.

Serials with Optional Air Condition System;

The Air Conditioning System is designed to cool the cabin to desired temperature settings and maintain comfortable humidity levels. The system consists of an engine driven compressor, condenser assembly, and evaporator assembly.

28 VDC for Air Conditioner Condenser operation is supplied through the 15-amp CONDENSER breaker on A/C BUS 1.

28 VDC for Air Conditioner Compressor operation is supplied through the 5-amp COMP/CTRL breaker on A/C BUS 2.

The aircraft engine must be running for the air conditioner to operate.

Distribution

Ventilation and cooling is provided by ducting fresh air from a NACA inlet on the RH cowl to the mixing chamber located on the lower RH portion of the firewall. Depending on operating mode and temperature selection, the air in the mixing chamber is ducted directly into the distribution system or, if in Air Conditioning mode (optional), is further cooled as it passes through the evaporator assembly located under the front passenger seat.

Heating is accomplished by mixing ventilation air from the fresh air inlet with heated air provided by the heat exchanger in the mixing chamber on the firewall. From the mixing chamber - which also controls airflow into the cabin compartment - the conditioned air is forced by ram air pressure or by blower fan into a distribution manifold mounted to the center, aft side of the firewall. The distribution manifold uses butterfly valves to control airflow to the floor and defrost vents. Airflow is ducted directly to all panel air vents.

Crew panel air vents are located inboard on the RH and LH bolster panels and on the outboard section of the instrument panel. The crew floor air vents are mounted to the bottom of each kick plate. The passenger panel air vents are chest high outlets mounted in the armrests integral to the LH and RH cabin wall trim panels. The passenger floor air vents are mounted to the bottom portion of the LH and RH cabin wall trim panels. The windshield diffuser, located in the glareshield assembly, directs conditioned air to the base of the windshield.

Heating

Ram air from the NACA inlet flows through the upper cowl and is ducted to the heat exchanger. The heated air is then routed to the hot air valve, mounted to the forward side of the firewall, which controls entry of hot air into the cabin distribution system. When the valve is open, the air flows into the cabin mixing chamber. When the valve is closed, the heated air exits into the engine compartment and is exhausted overboard with the engine cooling airflow. Cabin heat is regulated by controlling the volume of hot air admitted into the distribution system's air mixing chamber. The proportion of heated air to fresh air is accomplished using the temperature selector mounted on the RH instrument panel.

Cooling

Standard cabin cooling is provided by ram air admitted through the NACA inlet on the RH cowl to the fresh air valve, mounted to the forward side of the firewall. When the fresh air valve is open, the air flows into the cabin mixing chamber. When the fresh air valve is closed, the cooled air exits into the engine compartment and is exhausted overboard with the engine cooling airflow.

In Air Conditioning mode (optional), R134A refrigerant enters the engine mounted compressor as a vapor and is pressurized until the heat-laden vapor reaches a point much hotter than the outside air. The compressor then pumps the vapor to the condenser where it cools, changes to a liquid, and passes to the receiver-drier. The receiver-drier's function is to filter, remove moisture, and ensure a steady flow of liquid refrigerant into the evaporator through the expansion valve - a temperature controlled metering valve which regulates the flow of liquid refrigerant to the evaporator. Inside the evaporator, the liquid refrigerant changes state to a gas and in doing so, absorbs heat. The evaporator then absorbs the heat from the air passing over the coils and the moisture from the air condenses and is drained overboard through the belly of the aircraft. From the evaporator, the refrigerant vapor returns to the compressor where the cycle is repeated. During normal air conditioning operation, ram air from the fresh air intake flows into the evaporator assembly, is cooled as it passes through the evaporator coils, and is then ducted forward to the distribution manifold.

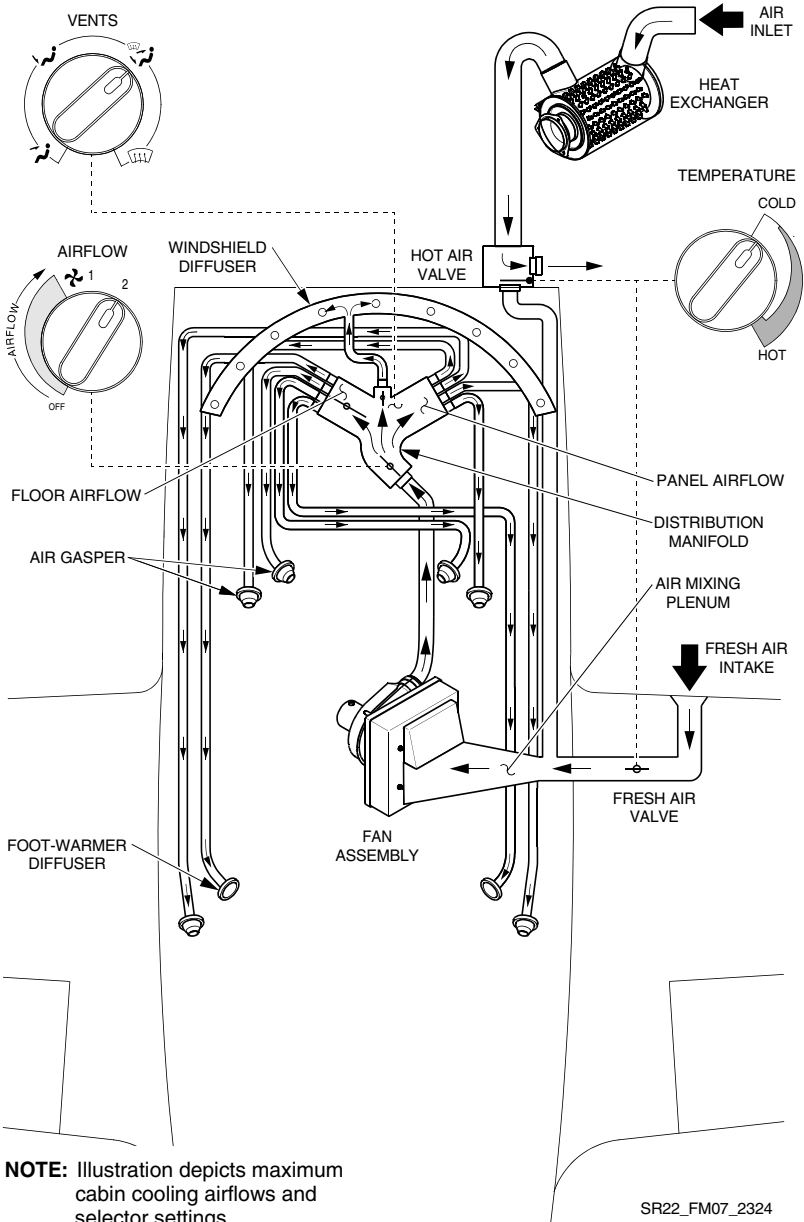

Figure 7-15
Standard Environmental System - Serials 1602 thru 2437*

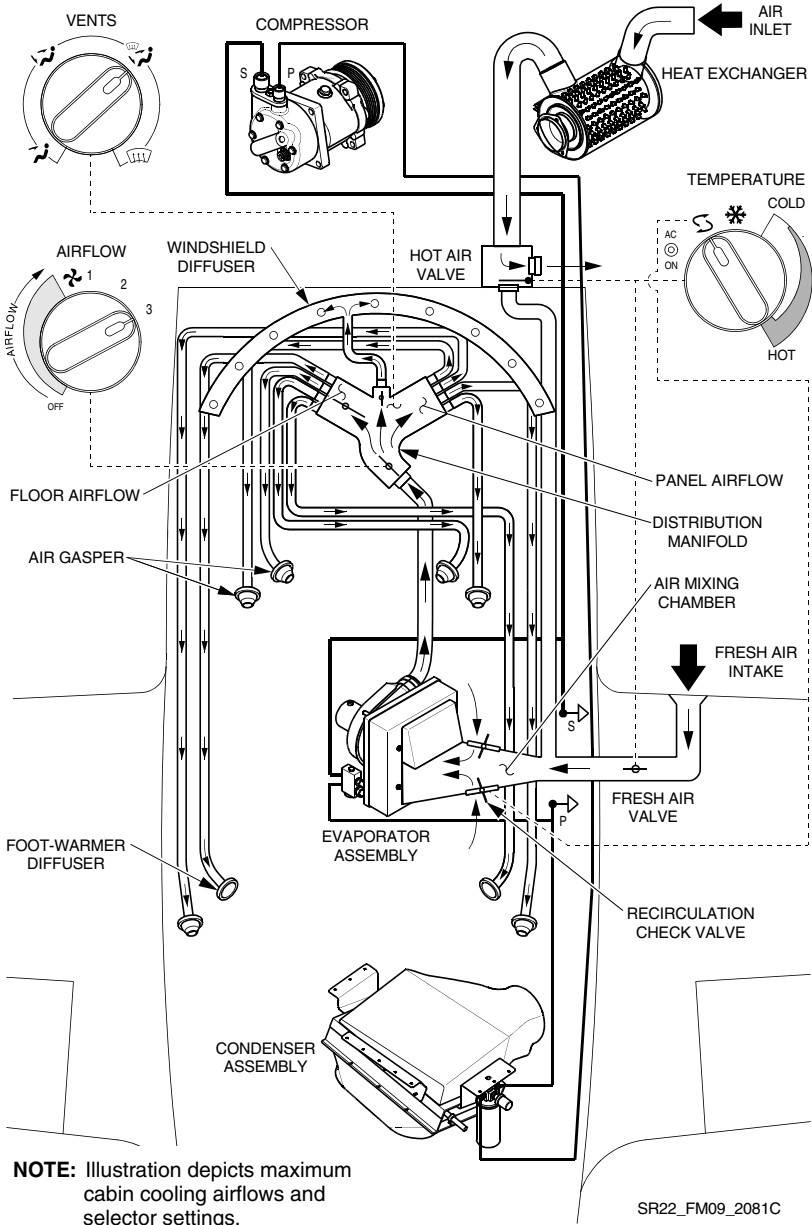
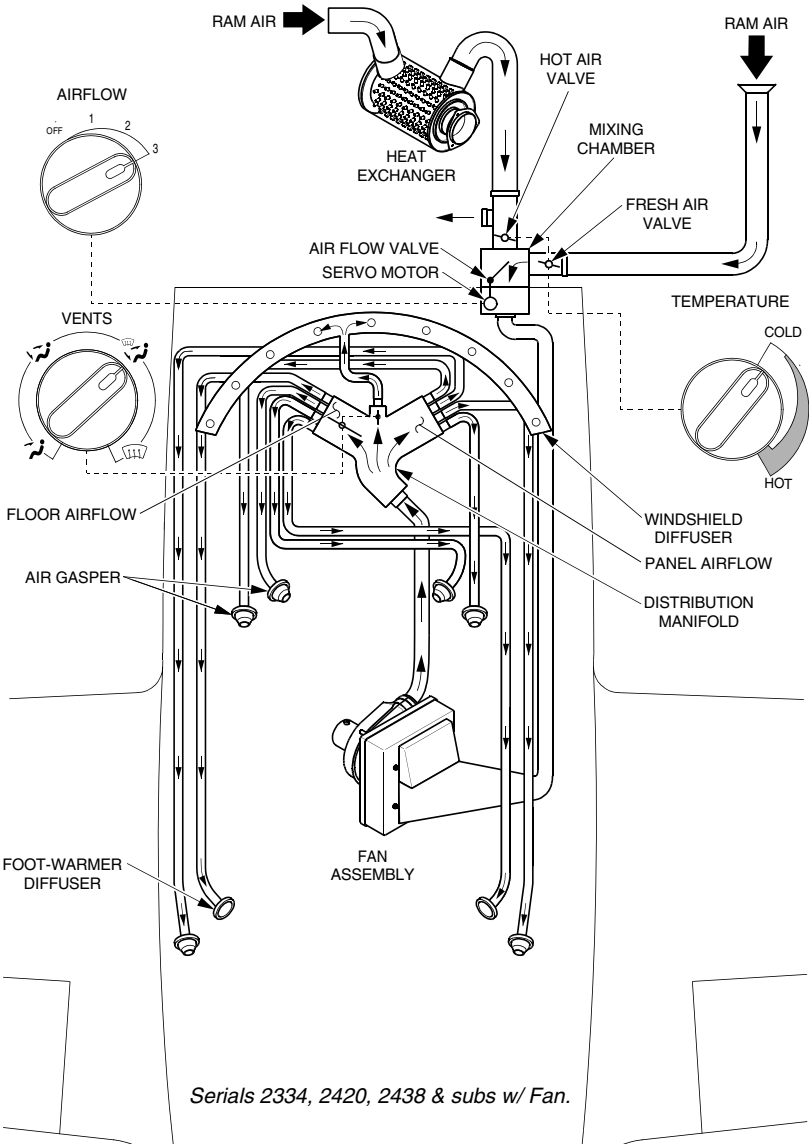

Figure 7-16

Optional Air Conditioning System - Serials 1602 thru 2437*



NOTE: Illustration depicts maximum cabin cooling airflows and selector settings.

SR22_FM09_2588A

Figure 7-17
Standard Environmental System - Serials 2438 and subs

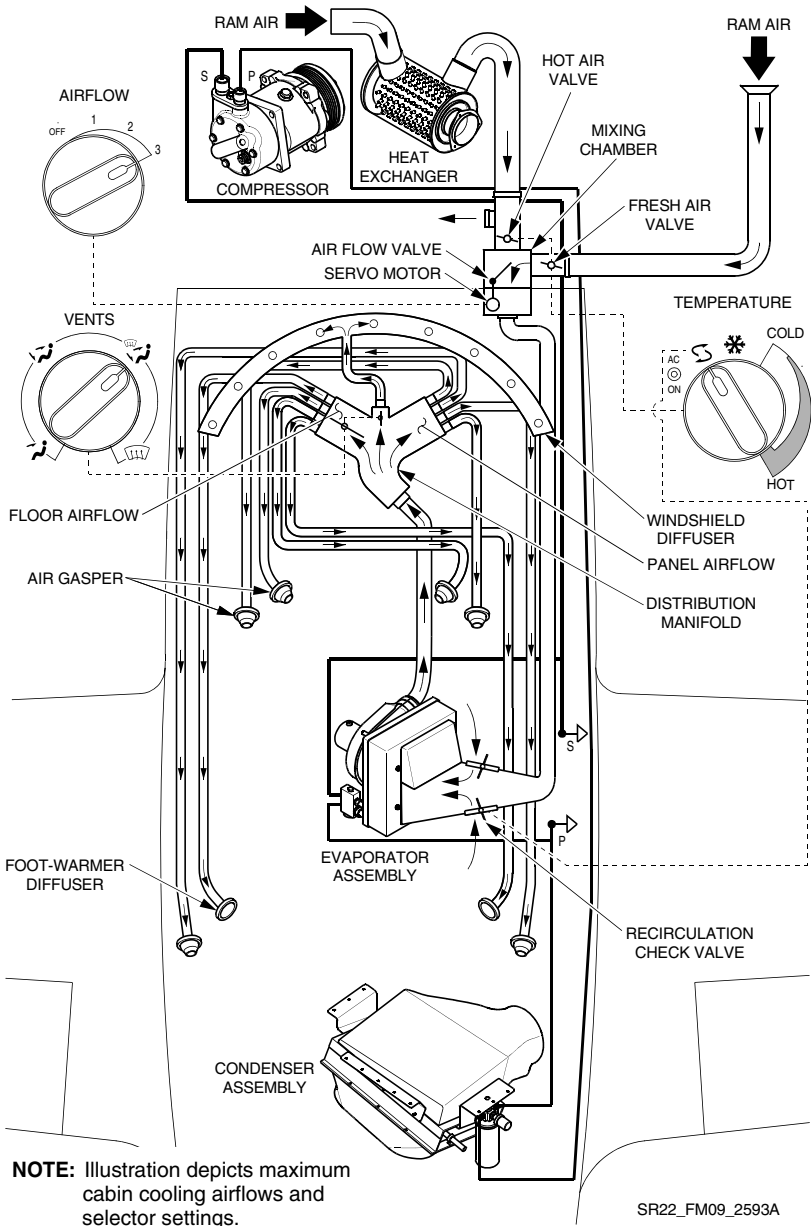

NOTE: Illustration depicts maximum cabin cooling airflows and selector settings.

SR22_FM09_2593A

Figure 7-18
Optional Air Conditioning System - Serials 2438 and subs
P/N 13772-001
Revision A10 7-85

Airflow Selection

Serials 1602, 1821, 1840, 1863 thru 2437: The airflow selector regulates the volume of airflow allowed into the cabin distribution system through mechanical linkage to a butterfly valve in the distribution manifold. If option installed, the blower fan is turned on when the selector dial exceeds the full open position.

Serials 2438 and subs: The airflow selector on the system control panel regulates the volume of airflow allowed into the cabin distribution system. When the airflow selector is moved past the OFF position an electro-mechanical linkage actuates a valve in the mixing chamber on the forward firewall to the full open position. The air is then distributed by either ram air or by an optional blower fan to the distribution manifold mounted to the center, aft side of the firewall. The optional blower fan system includes 0 (ram air), 1 (low fan), 2 (med fan), and 3 (high fan) airflow settings.

Vent Selection

Conditioned air from the distribution manifold can be proportioned and directed to passengers and/or the windshield by manipulating the cabin vent selector. The selector is mechanically linked to butterfly valves at the entrances to the windshield diffuser and the cabin floor ducting. There is continuous airflow to the panel and armrest eyeball outlets. Each occupant can control the flow rate from 'off' to maximum by rotating the nozzle.

When the selector is in the far left position, both butterfly valves are closed providing maximum airflow to the panel and armrest eyeball outlets.

Rotating the selector a quarter-turn clockwise opens the cabin floor butterfly valve allowing airflow to the rear seat foot warmer diffusers and the front seat outlets mounted to the underside of each kickplate.

Rotating the selector another quarter-turn clockwise opens the windshield diffuser butterfly valve which permits shared airflow to the defrosting mechanism and cabin floor outlets.

When the selector is in the far right position, the cabin floor butterfly valve is closed providing maximum airflow to the windshield diffuser.

If optional air condition system installed, when the full/max defrost position is selected, the air-conditioner is activated to provide conditioned, dry air to the diffuser to facilitate windshield defogging.

Temperature Selection

The temperature selector is mechanically linked to the hot air valve and fresh air intake valve. Rotating the selector simultaneously opens and closes the two valves, permitting hot and cold air to mix and enter the distribution system. Rotating the selector clockwise, permits warmer air to enter the system - counterclockwise, cooler air.

If optional air condition system installed, when the temperature selector is moved to the snowflake symbol, the butterfly valve on the firewall completely closes and the air-conditioner is activated. The A/C ON light will illuminate when the snowflake or recirculation symbol is selected.

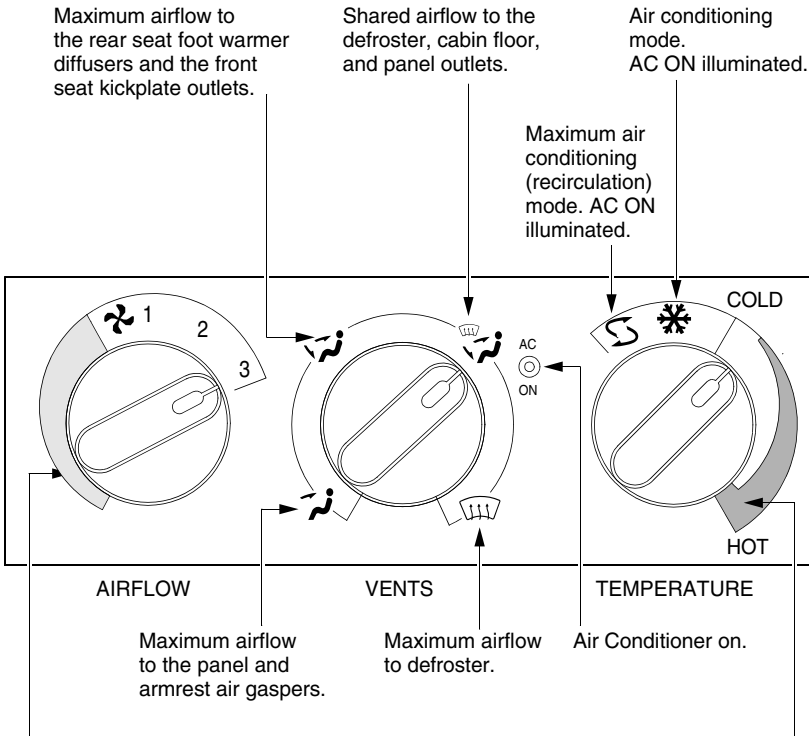

Rotating the selector controls the volume of airflow allowed into the cabin distribution system by opening and closing a butterfly valve in the distribution manifold. When the selector dial exceeds the full open position, the 3-speed blower fan is turned on.

Rotating the selector simultaneously opens and closes the hot and fresh air butterfly valves, permitting conditioned (mixed) air to enter distribution system.

NOTE: Illustration depicts settings for Emergency Procedures Smoke and Fume Elimination. If source of smoke and fume is firewall forward, turn Airflow Selector OFF.

SR22_FM09_2258A

Figure 7-19
Environmental System Operation - Serials 1602 thru 2437

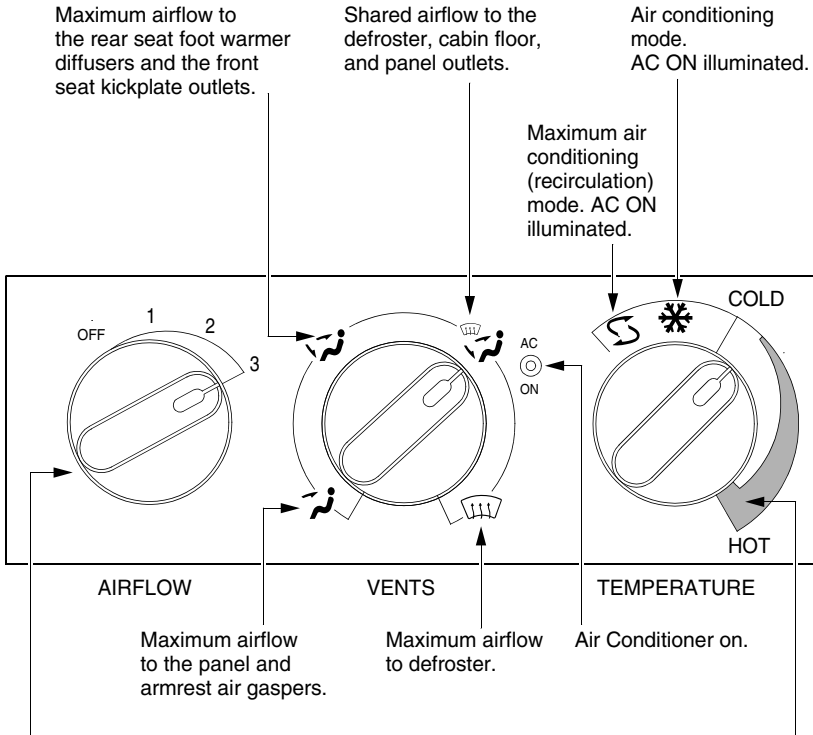

Rotating the selector controls the volume of airflow allowed into the cabin distribution system through use of an electro-mechanical linkage to a butterfly (hot air) valve in the mixing chamber on the forward firewall. When the airflow selector fan speed is moved to the 1, 2, or 3 position the electro-mechanical linkage actuates the hot air valve to the full open position and the 3-speed blower fan is turned on.

Rotating the selector simultaneously opens and closes the hot and fresh air butterfly valves, permitting conditioned (mixed) air to enter distribution system.

NOTE: Illustration depicts settings for Emergency Procedures Smoke and Fume Elimination.
If source of smoke and fume is firewall forward, turn Airflow Selector OFF.

SR22_FM09_2606A

Figure 7-20

Environmental System Operation - Serials 2438 and subs*

Pitot-Static System

The Pitot-Static system consists of a single heated Pitot tube mounted on the left wing and dual static ports mounted in the fuselage. The Pitot heat is pilot controlled through a panel-mounted switch. An internally mounted alternate static pressure source provides backup static pressure should that the primary static source becomes blocked. Water traps with drains, under the floor in the cabin, are installed at each Pitot and static line low point to collect any moisture that enters the system. The traps should be drained at the annual inspection and when water in the system is known or suspected.

Pitot Heat Switch

The heated Pitot system consists of a heating element in the pitot tube, a rocker switch labeled PITOT HEAT, and associated wiring. The switch and circuit breaker are located on the left side of the switch and control panel. When the pitot heat switch is turned on, the element in the Pitot tube is heated electrically to maintain proper operation in possible icing conditions. Pitot heat should be used only when required. The Pitot heat system operates on 28 VDC supplied through the 7.5-amp PITOT HEAT/COOLING FAN circuit breaker on the Non-Essential Bus.

Pitot Heat Light

Illumination of the amber PITOT HEAT caution light indicates that the Pitot Heat switch is in the 'on' position and the Pitot heater is not receiving electrical current. A current sensor on the Pitot heater power supply wire provides current sensing. The PITOT HEAT warning light operates on 28 VDC supplied through the 2-amp ANNUN / ENGINE INST circuit breaker on the Essential Bus.

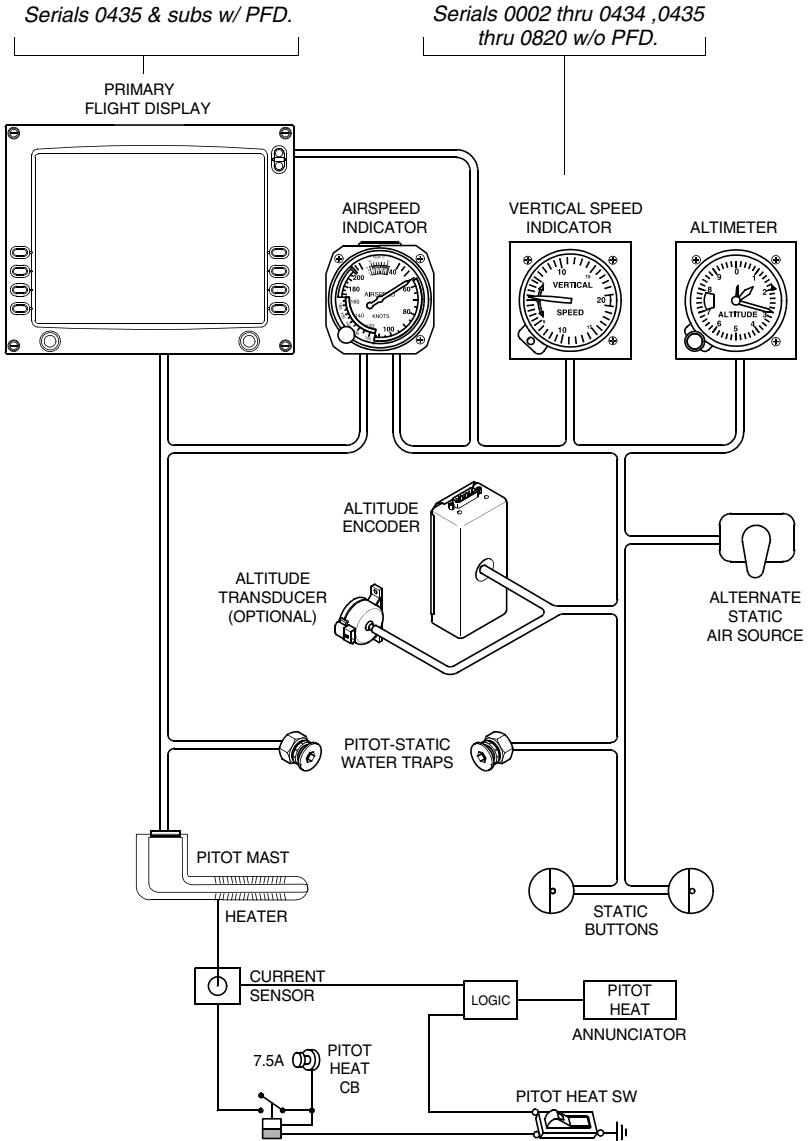

SR22_FM07_1013D

Figure 7-21
Pitot-Static System Schematic

Alternate Static Source

An alternate static pressure source valve is installed on the switch and control panel to the right of the pilot's leg. This valve supplies static pressure from inside the cabin instead of the external static port. If erroneous instrument readings are suspected due to water or ice in the pressure line going to the standard external static pressure source, the alternate static source valve should be turned on. Pressures within the cabin will vary with open heater/vents. Whenever the alternate static pressure source is selected, *refer to Section 5 airspeed calibration and altitude* for corrections to be applied.

Stall Warning System

The airplane is equipped with an electro-pneumatic stall warning system to provide audible warning of an approach to aerodynamic stall. The system consists of an inlet in the leading edge of the right wing, a pressure switch and associated plumbing, and a piezo-ceramic horn behind the instrument panel. As the airplane approaches a stall, the low pressure on the upper surface of the wings moves forward around the leading edge of the wings. As the low pressure area passes over the stall warning sense inlet, a slight negative pressure is sensed by the pressure switch. The pressure switch completes a ground circuit causing the warning horn to sound, *and Serials 2044 and subsequent*; the autopilot system to disconnect. The warning horn provides a 94dB continuous 2800 Hz tone. The warning sounds at approximately 5 knots above stall with full flaps and power off in wings level flight and at slightly greater margins in turning and accelerated flight. The system operates on 28 VDC supplied though the 2-amp STALL WARNING circuit breaker on the Essential Bus.

With battery power on, the stall warning system preflight check is accomplished as follows:

Stall warning system preflight check:

1. Use small suction cup and apply suction. A sound from the warning horn will confirm that the system is operative.

Standard Avionics

The following paragraphs and equipment descriptions describe all standard avionic installations offered for the SR22. The avionics navigation and communication equipment are mounted in the center console and are easily accessible from either pilot seat.

For detailed descriptions of specific avionic equipment, operating procedures, or data for optional avionic equipment, *refer to the equipment manufacturer's pilot's guide and the FAA Approved Airplane Flight Manual Supplement in Section 9* for specific information regarding the SR22 installation.

Standard avionics suites are available in the following configurations:

Avionics Configuration A - Serials 0002 through 1601, 1603 through 1643 and 1645 through 1662 without PFD:

- Moving Map Display (Avidyne MFD)
- Two-Axis Autopilot (S-Tec System 30)
- Integrated Audio System with Intercom (Garmin GMA 340)
- Marker Beacon Receiver (Garmin GMA 340)
- Two IFR Approach-Certified GPS (Garmin GNS 430 and Garmin GNS 420)
- Two VHF Communications Transceivers (Garmin GNS 430 and Garmin GNS 420)
- Single Navigation (VOR/LOC/GS) Receiver (GNS 430)
- Mode C Transponder with Altitude Encoder (Garmin GTX 327)
- Horizontal Situation Indicator
- Course Deviation Indicator

Avionics Configuration B - Serials 0002 through 1601, 1603 through 1643 and 1645 through 1662 without PFD:

- Moving Map Display (Avidyne MFD)
- Two-Axis Autopilot (S-Tec System 55X)
- Integrated Audio System with Intercom (Garmin GMA 340)
- Marker Beacon Receiver (Garmin GMA 340)
- Two IFR Approach-Certified GPS (Garmin GNS 430)

- Two VHF Communications Transceivers (Garmin GNS 430)
- Two Navigation (VOR/LOC/GS) Receiver (GNS 430)
- Mode C Transponder with Altitude Encoder (Garmin GTX 327)
- Electronic Navigation Display (Sandel SN3308)
- Course Deviation Indicator

Avionics Configuration PFD - Serials 0435 and subsequent with PFD:

- Moving Map Display (Avidyne MFD)
- Primary Flight Display (Avidyne PFD)
- Two-Axis Autopilot (S-Tec System 55X)
- Integrated Audio System with Intercom (Garmin GMA 340)
- Marker Beacon Receiver (Garmin GMA 340)
- Two IFR Approach-Certified GPS (Garmin GNS 430)
- Two VHF Communications Transceivers (Garmin GNS 430)
- Two Navigation (VOR/LOC/GS) Receiver (GNS 430)
- Mode C Transponder with Altitude Encoder (Garmin GTX 327)

Multi-Function Display

This airplane is equipped with an Avidyne FlightMax EX5000C 700-00004-XXX-() Multi-Function Flight Display (MFD). The MFD is a 10.4-inch landscape-oriented display mounted in the instrument panel. The MFD provides supplemental display of situational and navigation information to the pilot. This is accomplished by showing an icon representing the airplane against a moving map. The MFD accepts data from a variety of sources, including the GPS sensors, the WX-500 Stormscope, and the SkyWatch Traffic Advisory System. The unit is organized around logical grouping of information presented on “Pages.”

The Avidyne FlightMax EX-Series MFD is 10.4-inch diagonal color Active Matrix Liquid Crystal Display (AMLCD) integrated into a Control Display Unit (CDU), which displays the airplane current position and track against a moving map. The EX-Series MFD can perform the following functions:

- Generate and display a moving map based on GPS position data with obstacle and terrain data.
- Display Stormscope® lightning strike bearing and distance.
- Display Skywatch® traffic advisory information. (EX5000C only)
- Display a GPS flight plan based on pilot inputs.
- Display Normal and Emergency checklists as well as performance data.
- Display navigation data, such as groundspeed and track.

The pilot can configure the moving map display. Some of its configuration features are:

- Select Track-up or North-up modes.
- Select map scale.
- Select terrain features, such as airports and special use airspace and select color enhanced terrain.
- Select and view trip data from GPS.

Power for the MCU is 28 VDC supplied through the 5-amp MFD circuit breaker on the Avionics Non-Essential Bus.

• Note •

Serials 0002 through 1103 before MFD software version 530-00162-000 Revision 02; Do not use the Garmin 420 or 430 Navigators to display Stormscope lightning data when the Avidyne MFD's Lightning mode is set to either DATALINK or OFF. For the Garmin 420 or 430 Navigators to accurately display lightning strikes, the Lightning mode selected on the MFD's MAP Page, must be set to either STRIKE or CELL.

Refer to Avidyne FlightMax EX5000C Pilot's Guide, for a more complete description of the MFD, its operating modes, and additional detailed operating procedures.

Autopilot

Serials with Avionics Configuration A - 0002 through 1601, 1603 through 1643 and 1645 through 1662 without PFD:

These airplanes are equipped with an S-TEC System Thirty Autopilot with GPSS. This airplane is equipped with an S-TEC System Thirty Autopilot. This two-axis autopilot system receives roll axis control inputs from an integral electric turn coordinator and altitude information from an altitude transducer plumbed into the pitot-static system. The programmer, roll computer/amplifier, and annunciators are contained entirely within the turn coordinator case. The Multi-function Control Knob at the upper left of the turn coordinator provides mode selection, disengage, and turn command functions. A button on each control yoke handle may be used to disengage the autopilot. A separate pitch computer provides the ALT hold function. The S-Tec System Thirty Autopilot features:

- Roll Stabilization.
- Turn Command.
- NAV/LOC/GPS tracking; HI and LO sensitivity.
- Altitude Hold.
- GPS Steering (GPSS) for smoother turns onto a course or during course tracking.

A separate GPSS converter provides GPS roll steering to the autopilot. A GPSS/HDG button allows the operator to switch between HDG and Roll Steering modes. In the HDG mode the autopilot responds to the HDG bug on the HSI. In the GPSS mode, the autopilot responds to roll steering inputs from the GPS navigator. 28 VDC for autopilot operation is supplied through the 5-amp AUTOPILOT circuit breaker on the Essential Bus.

Refer to S-TEC System Thirty Autopilot Pilot's Operating Handbook (P/N 8777) dated Feb. 1999 or later, S-TEC-Meggitt Global Positioning System Steering (GPSS) Converter Pilot's Operating Handbook (P/N 8799) dated 8 Feb. 2001 or later, and the applicable POH supplement for a more complete description of the autopilot, its operating modes, and additional detailed operating procedures.

Serials with Avionics Configuration B - 0002 through 1601, 1603 through 1643 and 1645 through 1662 without PFD:

These airplanes are equipped with an S-TEC System 55X Autopilot with Altitude Selector/Alerter. The System 55X autopilot is a two-axis autopilot system. The system consists of a flight guidance programmer/computer, altitude encoder, altitude selector / alerter, turn coordinator, and HSI. Mode selection and vertical speed selection is made on the programmer/computer panel. A button on each control yoke handle may be used to disengage the autopilot. The autopilot makes roll changes through the aileron trim motor and spring cartridge and makes pitch changes for altitude hold through the elevator trim motor.

The SR22 installation of the S-Tec System 55X Autopilot features:

- Heading Hold and Command;
- NAV/LOC/GPS/GS tracking, high and low sensitivity, and automatic 45° course intercept;
- GPS Steering (GPSS);
- Altitude Pre-select, Hold and Command, Altitude display, and baro correction;
- Altitude and Decision Height (DH) alert; and
- Vertical Speed Hold and Command.

28 VDC for autopilot and altitude selector/alerter is supplied through the 5-amp AUTOPILOT circuit breaker on the Essential Bus.

Refer to S-Tec System Fifty-Five X Autopilot Pilot's Operating Handbook, P/N 87109 dated 8 November 2000 or later, Refer to S-Tec Altitude Selector / Alerter Pilot's Operating Handbook (POH) P/N 8716 or P/N 87110 (no revision or later) for full operational procedures and detailed description of operational modes of the Altitude Selector / Alerter.

Avionics Configuration PFD - Serials 0435 and subsequent with PFD:

These airplanes are equipped with an S-TEC System 55X or 55SR Autopilot and are fully integrated with the Entegra PFD. Heading, Altitude and VSI (55X only) reference bugs are provided to aid in autopilot control and pilot situational awareness. When in an active

autopilot mode, full guidance is provided, including smooth transitions to altitude and heading captures. If not in an active autopilot mode (i.e., “hand-flying”), there is no guidance other than the position of the appropriate bugs, as set by the pilot. A button on each control yoke handle may be used to disengage the autopilot.

The reference bugs' status, autopilot annunciations, and flight director steering command bars (if installed) will indicate when Entegra is coupled with the autopilot. A solid magenta Heading, Altitude, or VSI (55X only) bug indicates that the function is currently coupled to an active mode of the autopilot. A hollow magenta bug indicates that the function is not currently coupled to the autopilot in an active mode. In other words, a hollow bug indicates manual or “hand-flying” status.

In flight director equipped aircraft, when a vertical mode of the autopilot is being used, a set of flight director command bars will indicate the required steering of the aircraft to achieve the commanded tracking from the autopilot. In autopilot mode, “AP” will be in the autopilot annunciation field, the command bars will be visible and magenta and the aircraft should track the bars.

In flight director only mode, “FD” will be displayed in the autopilot annunciation field, the command bars will be visible and green, and the pilot is expected to actuate the flight controls as required to track the bars.

• Note •

One of the horizontal modes (HDG, NAV, GPSS) must be engaged on the autopilot control interface before a vertical mode can be used.

When HDG mode is engaged, rotation of the heading bug greater than 180 degrees may result in a reversal of turn direction.

The following six modes of the System 55X are supported by the Entegra PFD:

- ALT (Altitude Hold) Mode
- VS (Vertical Speed) Mode
- Altitude Capture Mode
- HDG (Heading Capture/Hold Mode)

- NAV Mode
- GPSS (GPS Steering) Mode

The following three modes of the System 55SR are supported by the Entegra PFD:

- ALT (Altitude Hold) Mode
- HDG (Heading Capture/Hold Mode)
- NAV Mode

28 VDC for autopilot and altitude selector/alerter is supplied through the 5-amp AUTOPILOT circuit breaker on the Essential Bus.

Refer to S-Tec System Fifty-Five X Autopilot Pilot's Operating Handbook, P/N 87109 dated 8 November 2000 or later, and the applicable POH supplement for a more complete description of the autopilot, its operating modes, and additional detailed operating procedures.

GPS Navigation

The Jeppesen Navigation Database provides access to data on Airports, Approaches, Standard Instrument Departures (SIDs), Standard Terminal Arrivals (STARs), VORs, NDBs, Intersections, Minimum Safe Altitudes, Controlled Airspace Advisories and Frequencies. North American and International databases are available. Database information is provided on a card that can be inserted into the card slot on the GPS unit. Subscription information is provided in a subscription packet provided with each system.

Serials with Avionics Configuration A - 0002 through 1601, 1603 through 1643 and 1645 through 1662 without PFD:

The airplane is equipped with two GPS navigators. The Garmin GNS 430 is designated GPS 1 and the Garmin GNS 420 is designated GPS 2. Both Garmin GPS navigators are IFR certified. The primary unit, designated GPS 1, is coupled to the airplane's HSI, Autopilot, and multifunction display. The secondary unit, designated GPS 2, is coupled to the airplane's HSI.

The GPS navigators are capable of providing IFR enroute, terminal, and approach navigation with position accuracies better than 15 meters. Each GPS navigator utilizes the Global Positioning System (GPS) satellite network to derive the airplane's position (latitude,

longitude, and altitude) and the altitude encoder to enhance the altitude calculation.

The GPS1 antenna is located above the headliner along the airplane centerline. The GPS2 antenna is located below the glareshield and behind the MFD. All GPS navigator controls and functions are accessible through the GPS receiver units' front control panels located in the center console. The panels include function keys, power switches, MSG and NAV status annunciators, a color LCD display (GNS 430), two concentric selector knobs on each panel, and a Jeppesen NavData card slot in each panel. The displays are daylight readable and automatically dimmed for low-light operation. The primary GPS navigator is powered by 28 VDC through the 5-amp GPS 1 and 7.5-amp COM 1 circuit breakers on the Avionics Essential Bus. The secondary GPS navigator is powered by 28 VDC through the 5-amp GPS 2 and the 7.5-amp COM 2 circuit breaker on the Avionics Non-Essential Bus.

Avionics Configuration B and PFD:

The airplane is equipped with two GPS navigators. Dual Garmin GNS 430s are designated GPS 1 and GPS 2. Both Garmin GPS navigators are IFR certified. The primary unit, designated GPS 1, is coupled to the airplane's HSI or PFD, Autopilot, and MFD. The secondary unit, designated GPS 2, is coupled to the airplane's HSI or PFD, and MFD.

The GPS navigators are capable of providing IFR enroute, terminal, and approach navigation with position accuracies better than 15 meters. Each GPS navigator utilizes the Global Positioning System (GPS) satellite network to derive the airplane's position (latitude, longitude, and altitude) and the altitude encoder to enhance the altitude calculation.

The GPS1 antenna is located above the headliner along the airplane centerline. The GPS2 antenna is located below the glareshield and behind the MFD. All GPS navigator controls and functions are accessible through the GPS receiver units' front control panels located in the center console. The panels include function keys, power switches, MSG and NAV status annunciators, a color LCD display (GNS 430), two concentric selector knobs on each panel, and a Jeppesen NavData card slot in each panel. The displays are daylight readable and automatically dimmed for low-light operation. The primary GPS navigator is powered by 28 VDC through the 5-amp GPS

1 and 7.5-amp COM 1 circuit breakers on the Avionics Essential Bus. The secondary GPS navigator is powered by 28 VDC through the 5-amp GPS 2 and the 7.5-amp COM 2 circuit breaker on the Avionics Non-Essential Bus.

Communication (COM) Transceivers

Avionics Configuration A, B, and PFD:

Two VHF communications (COM) transceivers are installed to provide VHF communication. The transceivers and integrated controls are mounted in the Garmin GNS 430 or GNS 420 units. The transceivers receive all narrow- and wide-band VHF communication transmissions transmitted within range of the selected frequency. The antennas pick up the signals and route the communication signals to the transceivers, which digitize the audible communication signal. The digitized audio is then routed to the audio control unit for distribution to the speakers or headphones.

COM 1 – The upper Garmin GNS 430 is designated COM 1. The Garmin GNS 430 control panel provides COM 1 transceiver active and standby frequency indication, frequency memory storage, and knob-operated frequency selection. The COM 1 transceiver provides either 720-channel (25 kHz spacing) or 2280-channel (8.33 kHz spacing) operation in a frequency range from 118.000 to 136.975 MHz. The COM 1 antenna is located above the cabin on the airplane centerline. 28 VDC for COM 1 transceiver operation is controlled through the Avionics Master Switch on the bolster switch panel and supplied through the 7.5-amp COM 1 circuit breaker on the Essential Avionics Bus.

COM 2 – The lower Garmin GNS 420 is designated COM 2. The Garmin GNS control panel provides COM 2 transceiver active and standby frequency indication, frequency memory storage, and knob-operated frequency selection. The COM 2 transceiver provides either 720-channel (25 kHz spacing) or 2280-channel (8.33 kHz spacing) operation in a frequency range from 118.000 to 136.975 MHz. The COM 2 antenna is located on the underside of the cabin on the airplane centerline. 28 VDC for COM 2 transceiver operation is controlled through the Avionics Master Switch on the bolster switch panel and supplied through the 7.5-amp COM 2 circuit breaker on the Non-Essential Avionics Bus.

Navigation (Nav) Receiver

Serials with Avionics Configuration A - 0002 through 1601, 1603 through 1643 and 1645 through 1662 without PFD:

The airplane is equipped with one NAV receiver integrated into the Garmin GNS 430 GPS Navigators (the GNS 420 does not incorporate a NAV receiver). Mounted in the upper radio rack slot, this unit is designated NAV 1. The GNS 430 has VHF Omnirange/Localizer (VOR/LOC) capability. The VOR/LOC receiver receives VOR/LOC on a frequency range from 108.000 Mhz to 117.950 Mhz with 50 kHz spacing. The GNS 430 has glideslope capability. Glideslope is received from 329.150 to 335.000 in 150 kHz steps. The receivers and integrated controls are mounted in the Garmin GNS 430 control display. The receiver controls provide active and standby frequency indication, frequency memory storage, and knob-operated frequency selection. IDENT audio output for VOR and LOC is provided to the audio system. The Nav antenna, mounted on top of the vertical tail, provides VOR/LOC input for both Nav receivers.

NAV 1 – The upper GARMIN GNS 430 is designated NAV 1. 28 VDC for navigation receiver operation is controlled through the Avionics Master Switch on the bolster switch panel and supplied through the 5-amp GPS1 circuit breaker on the Avionics Essential Bus row.

Avionics Configuration B and PFD:

The airplane is equipped with two NAV receivers integrated into the Garmin GNS 430 GPS Navigators. The upper unit is designated NAV 1 and the lower unit is designated NAV 2. The Nav receiver controls are integrated into the Garmin GNS control mounted in the center console. Each unit has VHF Omnirange/Localizer (VOR/LOC) capability. The VOR/LOC receiver receives VOR/LOC on a frequency range from 108.000 Mhz to 117.950 Mhz with 50 kHz spacing. The GNS 430 has glideslope capability. Glideslope is received from 329.150 to 335.000 in 150 kHz steps. The receiver control provides active and standby frequency indication, frequency memory storage, and knob-operated frequency selection. IDENT audio output for VOR and LOC is provided to the audio system. The Nav antenna, mounted on top of the vertical tail, provides VOR/LOC input for both Nav receivers.

NAV 1 – The upper GARMIN GNS 430 is designated NAV 1. 28 VDC for navigation receiver operation is controlled through the Avionics Master Switch on the bolster switch panel and supplied through the 5-amp GPS1 circuit breaker on the Avionics Essential Bus row.

NAV 2 – The lower GARMIN GNS 430 is designated NAV 2. 28 VDC for navigation receiver operation is controlled through the Avionics Master Switch on the bolster switch panel and supplied through the 5-amp GPS 2 circuit breaker on the Avionics Non-Essential Bus row.

Transponder

The airplane is equipped with a single Garmin GTX 327 ATC Mode C (identification and altitude) transponder with squawk capability. The transponder system consists of the integrated receiver/transmitter control unit, an antenna, and an altitude encoder. The receiver/transmitter receives interrogations from a ground-based secondary radar transmitter and then transmits to the interrogating Air Traffic Control Center. Digitized altitude information, provided by the altitude encoder, is plumbed into the airplane static system. The transponder and integrated controls are mounted in the center console. The transponder control provides active code display, code selection, IDENT button, and test functions. A FUNC (function) key allows for selection of pressure altitude, flight time, count-up timer and countdown timer modes. The display is daylight readable and dimming is operator controlled through the INST lights control on the instrument panel bolster. The transponder antenna is mounted on the underside of the fuselage just aft of the firewall. 28 VDC for transponder operation is controlled through the Avionics Master Switch on the bolster switch panel. 28 VDC for receiver, transmitter, and altitude encoder operation is supplied through the 2-amp ENCODER/XPONDER circuit breaker on the Avionics Non-Essential Bus.

Audio System

The airplane is equipped with a Garmin GMA 340 Audio Panel.

Refer to the Garmin GMA 340 Audio Panel Pilot's Operating Handbook, P/N 190-00149-10 Rev C or later, and the applicable POH supplement for a more complete description of the autopilot, its operating modes, and additional detailed operating procedures.

Headset/Microphone Installation

The airplane is equipped with provisions for four noise-canceling headsets with integrated microphones. The forward microphone-headsets use remote Push-To-Talk (PTT) switches located on the top of the associated control yoke grip. The rear headsets do not have COM transmit capabilities and do not require PTT switches. The microphone (MIC), headset, and automatic noise reduction (ANR) power jacks for the pilot and front seat passenger are located in the map case and similar jacks for the aft passengers are located on the aft portion of the center console. Audio to all four headsets is controlled by the individual audio selector switches on the audio control panel and adjusted for volume level by using the selected receiver volume controls.

Audio Input Jack

Two audio input jacks are provided on the aft portion of the center console. One jack is located near the convenience outlet for use by the pilot and forward passenger, and another is located further aft by the rear passenger ANR power jacks. These jacks can be used to plug in personal entertainment devices such as portable radios, cassette players, or CD players. Audio volume through these jacks is controlled by connected individual entertainment device.

Emergency Locator Transmitter

The airplane is equipped with a self-contained emergency locator transmitter (ELT). The transmitter and antenna are installed immediately behind the aft cabin bulkhead to the right of the airplane centerline. The main transmitter control switch, labeled ON-OFF-ARMED, on the transmitter is in the armed position for normal operations. A remote switch and indicator panel is installed immediately below the circuit breaker panel. The transmitter unit is mounted longitudinally in the airplane in order to detect deceleration greater than 3.5 ft/sec. If rapid deceleration is detected, the transmitter will repeatedly transmit VHF band audio sweeps at 121.5 MHz and 243.0 MHz approximately 0.5 seconds apart. The transmitter and portable antenna are accessible through an access at the base of the baggage compartment bulkhead. The ELT can be removed from the airplane and used as a personal locating device if it is necessary to leave the airplane after an accident. Eight dated "D" cell alkaline

batteries contained within the transmitter unit power the ELT transmitter. The batteries must be replaced at specified intervals based upon the date appearing on the battery (*refer to Airplane Maintenance Manual*).

ELT Remote Switch and Indicator Panel

The ELT remote switch and indicator panel located immediately below the circuit breaker panel, provides test and monitoring functions for the ELT. The panel contains a button labeled ON, a button labeled RESET, and a red LED (light). The red light flashes when the ELT is transmitting. The ON button is used to test the unit in accordance with the maintenance manual procedures. The RESET button can be used to cancel an inadvertent transmission. A 6-volt Lithium battery mounted in the panel powers the LED. The battery must be replaced at regular intervals (*refer to Airplane Maintenance Manual*).

In the event of an accident:

1. Verify ELT operation by noting that the ELT indicator light on the remote panel is flashing.
2. If possible, access the unit as described below and set the ELT main transmitter control switch ON.

Portable use of ELT:

- a. Remove access at lower aft center of baggage compartment.
- b. Disconnect fixed antenna lead from front of unit.
- c. Disconnect lead from remote switch and indicator unit.
- d. Loosen attach straps and remove transmitter unit and portable antenna.
- e. Attach portable antenna to antenna jack on front of unit.
- f. Set main control switch to ON.
- g. Hold antenna upright as much as possible.

Hour Meter(s)

Serials 0002 through 1820, 1822 through 1839, and 1841 through 1862: The airplane is equipped with an hour meter located inside the armrest storage compartment between the pilot and copilot seats. Recording begins when the BAT 1 switch is ON and either the ALT 1 or ALT 2 switch is ON.

Serials 0002 through 1601, 1603 through 1643, and 1645 through 1662: 28 VDC for hour meter operation is supplied through the 5-amp ENGINE INST circuit breaker.

Serials 1602, 1644, and 1663 through 1862: 28 VDC for hour meter operation is supplied through the 5-amp FUEL QTY / HOBBS circuit breaker on Main Bus 1.

Serials 1821, 1840, 1863 and subsequent: The airplane is equipped with two hour meters located inside the armrest storage compartment between the pilot and copilot seats. The #1 hour meter, labeled HOBBS begins recording when the BAT 1 switch is ON and either the ALT 1 or ALT 2 switch is ON. The #2 hour meter records flight time and is labeled FLIGHT. Recording begins when the airplane reaches a speed of approximately 35 KIAS and is controlled by a differential pressure switch connected to the Pitot-static system. 28 VDC for hour meter operation is supplied through the 5-amp FUEL QTY / HOBBS circuit breaker on Main Bus 1.

Digital Clock

Serials 0002 through 0434; The airplane is equipped with a 2¼" Davtron M803 digital clock located on the left instrument panel immediately outboard of the airspeed indicator. The clock provides Universal Time (UT), Local Time (LT), Elapsed Time (ET), Outside Air Temperature (OAT) in °C or °F, and Voltmeter functions. All features and functions are selectable from control buttons on the clock face. The clock receives the OAT signal from a temperature sensor installed immediately forward of the pilots door. The clock operates on 28 VDC supplied through the 5-amp ENGINE INST circuit breaker on Main Bus 1. Keep-alive power is supplied through a 5-amp fuse connected to the airplane Main Distribution Bus in the Master Control Unit (MCU). A replaceable AA battery is installed to provide up to three years battery back up.

SEL and CTL Buttons

All time keeping and set functions are addressable using the Select and Control buttons below the time display. Upon power up the clock will display Universal Time (UT). Pressing the Select button 3 times will display Local Time (LT), and Elapsed Time (ET) sequentially. Pressing the button again will return the display to UT.

Set UT or LT:

Use the Select button to select UT or LT as desired. Simultaneously press Select and Control buttons (tens of hours LED will flash). Press Control button repeatedly as required to increment digit to desired value. Press Select button to select the next digit to be set. After all digits have been set, press the Select button again to return to the normal mode.

Flight Time (FT):

The flight time (FT) option is not available in this installation. If FT is selected the display will 'zero.'

Elapsed Time (ET):

The ET mode may be used either in 'count-up' or in 'count-down' modes.

To set the count-up mode:

1. Select ET using the Select button; and

2. Press Control to activate count-up timer. Elapsed time counts up to 59 minutes, 59 seconds, and then switches to hours and minutes. Pressing the Control button again will reset the timer to zero.

To set the count-down mode:

1. Select ET using the Select button;
2. Input a 'count-down' time using the same technique as setting UT or LT (a maximum of 59 minutes, 59 seconds may be entered);
3. Press the Select button to exit the set mode; and
4. Press Control to start the count down. At zero, the alarm activates and the display flashes. Pressing either Select or Control deactivates the alarm.

Test Mode:

To enter the self-test mode, hold the Select button for 3 seconds. The display will indicate "88:88" and all four (UT, LT, FT, ET) annunciators will come on.

OAT – VOLTS Button

• Note •

OAT indication is subject to small errors. It is possible for ice to accrete on the aircraft at indicated temperatures higher than 32°F (0° C).

Serials 0002 through 0434; The red OAT-VOLTS button is used to display Outside Air Temperature and airplane Main Bus voltage. When the airplane is powered down, the upper display will display the clock's back-up battery voltage. Upon power up, the display will show the airplane's Main Bus voltage. Pressing the button displays OAT in °F. Pressing the button again displays OAT in °C.

Serials 0435 and subsequent with PFD: Outside Air Temperature annunciation is integrated into the PFD.

Cirrus Airplane Parachute System

The SR22 is equipped with a Cirrus Airplane Parachute System (CAPS) designed to bring the aircraft and its occupants to the ground in the event of a life-threatening emergency. The system is intended to save the lives of the occupants but will most likely destroy the aircraft and may, in adverse circumstances, cause serious injury or death to the occupants. Because of this it is important to carefully read the CAPS descriptions in this section, Section 3, Emergency Procedures and Section 10, Safety and consider when and how you would use the system.

• WARNING •

The parachute system can be activated at any time. The solid-propellant rocket flight path is upward from the parachute cover. Stay clear of parachute canister area when aircraft is occupied. Do not allow children in the aircraft unattended.

System Description

The CAPS consists of a parachute, a solid-propellant rocket to deploy the parachute, a rocket activation handle, and a harness imbedded within the fuselage structure.

A composite box containing the parachute and solid-propellant rocket is mounted to the airplane structure immediately aft of the baggage compartment bulkhead. The box is covered and protected from the elements by a thin composite cover.

The parachute is enclosed within a deployment bag that stages the deployment and inflation sequence. The deployment bag creates an orderly deployment process by allowing the canopy to inflate only after the rocket motor has pulled the parachute lines taut.

The parachute itself is a 2400-square-foot round canopy equipped with a slider, an annular-shaped fabric panel with a diameter significantly less than the open diameter of the canopy. The slider has grommets spaced around its perimeter. The canopy suspension lines are routed through these grommets so that the slider is free to move along the suspension lines. Since the slider is positioned at the top of the suspension lines near the canopy, at the beginning of the deployment sequence the slider limits the initial diameter of the parachute and the

rate at which the parachute inflates. As the slider moves down the suspension lines the canopy inflates.

A three-point harness connects the airplane fuselage structure to the parachute. The aft harness strap is stowed in the parachute canister and attached to the structure at the aft baggage compartment bulkhead. The forward harness straps are routed from the canister to firewall attach points just under the surface of the fuselage skin. When the parachute deploys, the forward harness straps pull through the fuselage skin covering from the canister to the forward attach points.

Activation Handle

CAPS is initiated by pulling the CAPS Activation T-handle installed in the cabin ceiling on the airplane centerline just above the pilot's right shoulder. A placarded cover, held in place with hook and loop fasteners, covers the T-handle and prevents tampering with the control. The cover is removed by pulling the black tab at the forward edge of the cover.

Pulling the activation T-handle will activate the rocket and initiate the CAPS deployment sequence. To activate the rocket, two separate events must occur:

1. Pull the activation T-handle from its receptacle. Pulling the T-handle removes it from the o-ring seal that holds it in place and takes out the slack in the cable (approximately two inches (5 cm) of cable will be exposed). Once the slack is removed, the T-handle motion will stop and greater force will be required to activate the rocket.
2. Clasp both hands around activation T-handle and pull straight downward with a strong, steady, and continuous force until the rocket activates. A chin-up type pull works best. Up to 45.0 pounds (20.4 Kg) force, or greater, may be required to activate the rocket. *Serials 0002 thru 0820 before SB2X-95-17, 0821 & subs before SB2X-95-18:* The greater force required occurs as the cable arms and then releases the rocket igniter firing pin. When the firing pin releases, two primers discharge and ignite the rocket fuel. *Serials 0002 thru 0820 after SB2X-95-17, 0821 & subs after SB2X-95-18:* The greater force required occurs as the cable arms and then releases the igniter switch plunger activating the electronic igniter.

• Note •

Jerking or rapidly pulling on the activation T-handle greatly increases the pull forces required to activate the rocket.

Attempting to activate the rocket by pushing the activation T-handle forward and down limits the force that can be applied. Pulling the activation T-handle straight down generates the greatest force.

A maintenance safety pin is provided to ensure that the activation handle is not pulled during maintenance. However, there may be some circumstances where an operator may wish to safety the CAPS system; for example, the presence of unattended children in the airplane, the presence of people who are not familiar with the CAPS activation system in the airplane, or during display of the airplane.

The pin is inserted through the handle retainer and barrel locking the handle in the “safe” position. A “Remove Before Flight” streamer is attached to the pin.

• **WARNING** •

After maintenance has been performed or any other time the system has been safetied, operators must verify that the pin has been removed before further flight.

Deployment Characteristics

When the rocket launches, the parachute assembly is extracted outward due to rocket thrust and rearward due to relative wind. In approximately two seconds the parachute will begin to inflate.

When air begins to fill the canopy, forward motion of the airplane will dramatically be slowed. This deceleration increases with airspeed but in all cases within the parachute envelope should be less than 3 g's. During this deceleration a slight nose-up may be experienced, particularly at high speed; however, the rear riser is intentionally snubbed short to preclude excessive nose-up pitch. Following any nose-up pitching, the nose will gradually drop until the aircraft is hanging nose-low beneath the canopy.

Eight seconds after deployment, the rear riser snub line will be cut and the aircraft tail will drop down into its final approximately level attitude. Once stabilized in this attitude, the aircraft may yaw slowly back and

forth or oscillate slightly as it hangs from the parachute. Descent rate is expected to be less than 1700 feet per minute with a lateral speed equal to the velocity of the surface wind. In addition, surface winds may continue to drag the aircraft after ground impact.

• Caution •

Ground impact is expected to be equivalent to touchdown from a height of approximately 13 feet. While the airframe, seats and landing gear are designed to accommodate this stress, occupants must prepare for it in accordance with the CAPS Deployment procedure in Section 3 - Emergency Procedures.

• Note •

The CAPS is designed to work in a variety of aircraft attitudes, including spins. However, deployment in an attitude other than level flight may yield deployment characteristics other than those described above.

Section 8

Handling, Servicing, Maintenance

Table of Contents

Introduction	8-3
Operator's Publications	8-3
Service Publications	8-3
Ordering Publications	8-4
Airplane Records and Certificates	8-5
Airworthiness Directives	8-6
Airplane Inspection Periods	8-6
Annual Inspection	8-6
100-Hour Inspection	8-7
Cirrus Design Progressive Inspection Program	8-7
Pilot Performed Preventative Maintenance	8-8
Ground Handling	8-10
Application of External Power	8-10
Towing	8-11
Taxiing	8-12
Parking	8-13
Tiedown	8-14
Leveling	8-14
Jacking	8-15
Servicing	8-16
Landing Gear Servicing	8-16
Brake Servicing	8-16
Tire Inflation	8-18
Propeller Servicing	8-18
Oil Servicing	8-19
Fuel System Servicing	8-22
Fuel Contamination and Sampling	8-24
Draining Fuel System	8-25
Battery Service	8-25
Cleaning and Care	8-26
Cleaning Exterior Surfaces	8-26
Cleaning Interior Surfaces	8-30

Section 8 - Handling, Servicing, and Maintenance

Servicing

Landing Gear Servicing

Serials w/ tubeless tire:

The main landing gear wheel assemblies use 15 x 6.00 x 6 tubeless tires. The nose wheel assembly uses a 5.00 x 5 tubeless tire.

Brake Servicing

Brake Replenishing

Serials w/ Beringer Brake System:

The brake system is filled with MIL-PRF-87257 hydraulic brake fluid.

To replenish brake fluid:

1. Chock tires and release parking brake.
2. Remove top engine cowling to gain access to hydraulic fluid reservoir.
3. Clean reservoir cap and area around cap before opening reservoir cap.
4. Remove cap and add MIL-PRF-87257 hydraulic fluid as necessary to fill reservoir.
5. Install cap, inspect area for leaks, and then install and secure engine cowling.

Tire Inflation

To inflate tires:

1. Remove inspection buttons on wheel pants to gain access to valve stems. It may be necessary to move airplane to get valve stem aligned with the access hole.
2. Remove valve stem cap and verify tire pressure with a dial-type tire pressure gage.

• Caution •

The LH and RH main wheel tire pressures must be within 20 psi of each other to ensure the load is evenly distributed between the main wheels.

3. Inflate nose tire to 30 - 35 psi (207 - 241 kPa) and main wheel tires to 60 - 65 psi (414 - 448 kPa).
4. Replace valve stem cap and inspection buttons.

Introduction

This section provides general guidelines for handling, servicing and maintaining your Cirrus Design SR22. In order to ensure continued safe and efficient operation of your airplane, keep in contact with your Authorized Cirrus Service Center to obtain the latest information pertaining to your aircraft.

Operator's Publications

The FAA Approved Airplane Flight Manual and Pilot's Operating Handbook (POH) is provided at delivery. Additional or replacement copies may be obtained from Cirrus Design by contacting the Customer Service Department.

Service Publications

The following service publications are available for purchase from Cirrus Design for the SR22:

- Airplane Maintenance Manual (AMM) – GAMA-type Maintenance Manual divided into chapters as specified by GAMA and ATA covering inspection, servicing, maintenance, troubleshooting, and repair of the airplane structure, systems, and wiring. Revision Service for this manual is also available. A current copy of the AMM is provided at delivery.
- Engine Operators and Maintenance Manual – Cirrus Design provides a Teledyne Continental Engine Operator's and Maintenance Manual at the time of delivery. Engine and engine accessory overhaul manuals can be obtained from the original equipment manufacturer.
- Avionics Component Operator and Maintenance Manuals – Cirrus Design provides all available operator's manuals at the time of delivery. Maintenance manuals, if available, may be obtained from the original equipment manufacturer.

Cirrus Design offers a Subscription Service for the Service Bulletins, Service Letters and Options Letters issued from the factory. This service is offered to interested persons such as owners, pilots and mechanics at a nominal fee. Interested parties may obtain copies and subscription service for these documents by contacting Customer Service at Cirrus Design.

- Service Bulletins – -are of special importance. When you receive a Service Bulletin, comply with it promptly.
- Service Advisory Notices – are used to notify you of optional Service Bulletins, supplier Service Bulletins or Service Letters affecting your airplane, and maintenance data or corrections not requiring a Service Bulletin. Give careful attention to the Service Advisory Notice information.

Ordering Publications

SR22 publications, revision service, and service publication subscription service may be obtained by contacting Customer Service at Cirrus Design as follows:

Cirrus Design Corporation
Customer Service
4515 Taylor Circle
Duluth, MN 55811
Phone: 218 727-2737
FAX: 218 727-2148

Make sure to include airplane serial number and owner's name in all correspondence for accurate processing of your documentation needs.

Airplane Records and Certificates

The Federal Aviation Administration (FAA) requires that certain data, certificates, and licenses be displayed or carried aboard the airplane at all times. Additionally, other documents must be made available upon request. The mnemonic acronym “ARROW” is often used to help remember the required documents.

• Note •

Owners of aircraft not registered in the United States should check with the registering authority for additional requirements.

Required Documents		Note
A	Airworthiness Certificate <i>FAA Form 8100-2</i>	Must be displayed at all times
R	Registration Certificate <i>FAA Form 8050-3</i>	Must be in the aircraft for all operations.
R	Radio Station License <i>FCC Form 556</i>	Required only for flight operations outside the United States
O	Operating Instructions	FAA Approved Flight Manual and Pilot's Operating Handbook fulfills this requirement
W	Weight & Balance Data	Included in FAA Approved Airplane Flight Manual and Pilot's Operating Handbook. Data must include current empty weight, CG, and equipment list.

Other Documents		Note
Airplane Logbook		Must be made available upon request
Engine Logbook		Must be made available upon request
Pilot's Checklist		Available in cockpit at all times.

Airworthiness Directives

The Federal Aviation Administration (FAA) publishes Airworthiness Directives (AD's) that apply to specific aircraft and aircraft appliances or accessories. AD's are mandatory changes and must be complied with within a time limit set forth in the AD. Operators should periodically check with Cirrus Service Centers or A&P mechanic to verify receipt of the latest issued AD for their airplane.

Airplane Inspection Periods

- Note •

FAR 1.1 defines time in service, with respect to maintenance time records, as "the time from the moment an aircraft leaves the surface of the earth until it touches it at the next point of landing."

Serials 1821, 1840, 1863 and subsequent: The #2 Hour Meter, located in the center console and labeled FLIGHT, begins recording when the airplane reaches approximately 35 KIAS and should be used to track maintenance time intervals as it more accurately records time in service than the #1 Hour Meter which begins recording when the BAT 1 switch is ON and either the ALT 1 or ALT 2 switch is ON.

The inspection items specified in the Annual/100 Inspection have been determined by the average aircraft use rate of the typical owner. Non-commercially operated aircraft that are flown significantly more than 100 hours per year should consider additional inspections commensurate with the hours flown. 100-Hour Inspection or enrollment in a Progressive Inspection Program should be considered in addition to the normally required Annual Inspection. The Annual Inspection interval may also be shortened to accommodate high utilization rate.

Annual Inspection

Unless enrolled in a Progressive Inspection Program, The U.S. Federal Aviation Regulations require all civil aircraft must undergo a thorough Annual Inspection each twelve calendar months. Annual Inspections are due on the last day of the twelfth month following the

last Annual Inspection. For example: If an Annual Inspection were performed on 19 November 1998, the next Annual Inspection will be due 30 November 1999. Annual Inspections must be accomplished regardless of the number of hours flown the previous year and can only be performed by a licensed Airframe and Powerplant (A&P) mechanic holding an Inspection Authorization (IA). All Cirrus Authorized Service Centers can perform Annual Inspections. The inspection is listed, in detail, in Chapter 5 of the Aircraft Maintenance Manual.

100-Hour Inspection

If the airplane is used commercially, in addition to the Annual Inspection requirement, the Federal Aviation Regulations requires that the airplane undergo a 100-Hour Inspection each 100 hours of flight operation. The scope of the 100-Hour Inspection is identical to the Annual Inspection except that it can be accomplished by a licensed A&P mechanic. The 100-hour interval may be exceeded by not more than 10 flight hours in order to reach a place where the inspection can be accomplished. Any flight hours used to reach an inspection station must be deducted from the next 100-Hour Inspection interval. The inspection is listed, in detail, in Chapter 5 of the Aircraft Maintenance Manual.

Cirrus Design Progressive Inspection Program

In lieu of the above requirements, an airplane may be inspected using a Progressive Inspection Program in accordance with the Federal Aviation Regulation Part 91.409.

The Cirrus Design Progressive Inspection Program provides for the complete inspection of the airplane utilizing a five-phase cyclic inspection program. A total of eight inspections are accomplished over the course of 400 flight hours, with an inspection occurring every 50 flight hours. The inspection items to be covered in the Progressive Inspection are very similar to the Annual Inspection items. The Progressive Inspection will accomplish a full Inspection of the airplane at 400 flight hours or at 12 calendar months. The inspection is listed, in detail, in Chapter 5 of the Aircraft Maintenance Manual.

Pilot Performed Preventative Maintenance

The holder of a Pilot Certificate issued under FAR Part 61 may perform certain preventive maintenance described in FAR Part 43, Appendix A. This maintenance may be performed only on an aircraft that the pilot owns or operates and which is not used in air carrier service. The regulation also stipulates that the pilot must also complete the appropriate logbook entries. The following is a list of the maintenance that the pilot may perform:

• Note •

The pilot should have the ability and manual procedures for the work to be accomplished.

The pilot may not accomplish any work involving the removal or disassembly of primary structure or operating system, or interfere with an operating system, or affect the primary structure.

- Remove, install, and repair tires.
- Clean, grease, or replace wheel bearings
- Replace defective safety wire or cotter pins.
- Lubrication not requiring disassembly other than removal of non-structural items such as access covers, cowlings, or fairings.

• Caution •

Do not use unapproved lubricants. Unapproved lubricants may damage control system components, including but not limited to engine and flight controls. *Refer to the Airplane Maintenance Manual* for approved lubricants.

- Replenish hydraulic fluid in the hydraulic and brake reservoirs.
- Refinish the airplane interior or exterior (excluding balanced control surfaces) with protective coatings.
- Repair interior upholstery and furnishings.
- Replace side windows.
- Replace bulbs, reflectors and lenses of position and landing lights.
- Replace cowling not requiring removal of the propeller.
- Replace, clean or set spark plug gap clearance.

- Replace any hose connection, except hydraulic connections, with replacement hoses.
- Clean or replace fuel and oil strainers, as well as replace or clean filter elements.
- Replace prefabricated fuel lines.
- Replace the battery and check fluid level and specific gravity.

Logbook Entry

After any of the above work is accomplished, appropriate logbook entries must be made. Logbook entries should contain:

- The date the work was accomplished.
- Description of the work.
- Number of hours on the aircraft.
- The certificate number of pilot performing the work.
- Signature of the individual doing the work.

Logbooks should be complete and up to date. Good records reduce maintenance cost by giving the mechanic information about what has or has not been accomplished.

Ground Handling

Application of External Power

A ground service receptacle, located just aft of the cowl on the left side of the airplane, permits the use of an external power source for cold weather starting and maintenance procedures.

• **WARNING** •

If external power will be used to start engine, keep yourself, others, and power unit cables well clear of the propeller rotation plane.

To apply external power to the airplane:

• **Caution** •

Do not use external power to start the airplane with a 'dead' battery or to charge a dead or weak battery in the airplane. The battery must be removed from the airplane and battery maintenance performed in accordance with the appropriate Airplane Maintenance Manual procedures.

1. Ensure that external power source is regulated to 28 VDC.
2. Check BAT and AVIONICS power switches are 'off.'
3. Plug external power source into the receptacle.
4. Set BAT 1 switch to ON. 28 VDC from the external power unit will energize the main distribution and essential distribution buses. The airplane may now be started or electrical equipment operated.
5. If avionics are required, set AVIONICS power switch ON.

• **Caution** •

If maintenance on avionics systems is to be performed, it is recommended that external power be used. Do not start or crank the engine with the AVIONICS power switch 'on.'

To remove external power from airplane:

1. If battery power is no longer required, set BAT 1 switch 'off.'
2. Pull external power source plug.

Towing

The airplane may be moved on the ground by the use of the nose wheel steering bar that is stowed in the rear baggage compartment or by power equipment that will not damage or excessively strain the nose gear assembly. The steering bar is engaged by inserting it into lugs just forward of the nose wheel axle.

• Caution •

While pushing the aircraft backward, the tow bar must be installed to keep the nose wheel from turning abruptly.

Do not use the vertical or horizontal control surfaces or stabilizers to move the airplane. If a tow bar is not available, use the wing roots as push points.

Do not push or pull on control surfaces or propeller to maneuver the airplane.

Do not tow the airplane when the main gear is obstructed with mud or snow.

If the airplane is to be towed by vehicle, do not turn the nose wheel more than 90 degrees either side of center or structural damage to the nose gear could result.

1. Refer to *Airplane Three View (Section 1, Figure 1-1)* and *Turning Radius (Section 1, Figure 1-2)* or clearances. Be especially cognizant of hangar door clearances.
2. Insert tow bar into the lugs just forward of the nose wheel axle.
3. Release parking brake and remove chocks
4. Move airplane to desired location.
5. Install chocks
6. Remove tow bar.

To obtain a minimum radius turn during ground handling, the airplane may be rotated around either main landing gear by pressing down on a fuselage just forward of the horizontal stabilizer to raise the nosewheel off the ground.

Taxiing

Before attempting to taxi the airplane, ground personnel should be instructed and authorized by the owner to taxi the airplane. Instruction should include engine starting and shutdown procedures in addition to taxi and steering techniques.

• Caution •

Verify that taxi and propeller wash areas are clear before beginning taxi.

Do not operate the engine at high RPM when running up or taxiing over ground containing loose stones, gravel, or any loose material that may cause damage to the propeller blades.

Taxi with minimum power needed for forward movement. Excessive braking may result in overheated or damaged brakes.

1. Remove chocks.
2. Start engine in accordance with Starting Engine procedure (Section 4).
3. Release parking brake.
4. Advance throttle to initiate taxi. Immediately after initiating taxi, apply the brakes to determine their effectiveness. During taxiing, use differential braking to make slight turns to ascertain steering effectiveness.

• Caution •

Observe wing clearance when taxiing near buildings or other stationary objects. If possible, station an observer outside the airplane.

Avoid holes and ruts when taxiing over uneven ground.

5. Taxi airplane to desired location.
6. Shut down airplane and install chocks and tie-downs in accordance with Shutdown procedure (Section 4).

Parking

The airplane should be parked to protect the airplane from weather and to prevent it from becoming a hazard to other aircraft. The parking brake may release or exert excessive pressure because of heat buildup after heavy braking or during wide temperature swings. Therefore, if the airplane is to be left unattended or is to be left overnight, chock and tie down the airplane.

1. For parking, head airplane into the wind if possible.
2. Retract flaps.
3. Set parking brake by first applying brake pressure using the toe brakes and then pulling the PARK BRAKE knob aft.

• Caution •

Care should be taken when setting overheated brakes or during cold weather when accumulated moisture may freeze a brake.

4. Chock both main gear wheels.
5. Tie down airplane in accordance with tiedown procedure in this section.
6. Install a pitot head cover. Be sure to remove the pitot head cover before flight.
7. Cabin and baggage doors should be locked when the airplane is unattended.

Tiedown

The airplane should be moored for immovability, security and protection. FAA Advisory Circular AC 20-35C, Tiedown Sense, contains additional information regarding preparation for severe weather, tiedown, and related information. The following procedures should be used for the proper mooring of the airplane:

1. Head the airplane into the wind if possible.
2. Retract the flaps.
3. Chock the wheels.
4. Secure tie-down ropes to the wing tie-down rings and to the tail ring at approximately 45-degree angles to the ground. When using rope or non-synthetic material, leave sufficient slack to avoid damage to the airplane should the ropes contract.

• Caution •

Anchor points for wing tiedowns should not be more than 18 feet apart to prevent eyebolt damage in heavy winds.

Use bowline knots, square knots, or locked slipknots. Do not use plain slipknots.

Leveling

The airplane is leveled longitudinally by means of a spirit level placed on the pilot door sill and laterally by means of a spirit level placed across the door sills. Alternately, sight the forward and aft tool holes along waterline 95.9 to level airplane. *Refer to Section 6, Airplane Weighing Procedures and Section 6, Figure 6-2, for illustration.*

Jacking

Two jacking points are provided: one at each wing tiedown. Jack points (pads) are stowed in the baggage compartment. The airplane may be jacked using two standard aircraft hydraulic jacks at the wing jacking points and a weighted tailstand attached to the tail tiedown.

Raise Airplane

• Caution •

Do not jack the aircraft outside or in open hangar with winds in excess of 10 mph.

The empty CG is forward of the wing jacking points. To prevent airplane from tipping forward during maintenance or jacking, use a weighted tailstand (300-lb minimum) attached to the tail tiedown.

1. Position airplane on a hard, flat, level surface.
2. Remove tiedown rings from wings. Stow tie-down rings in baggage compartment.
3. Attach a weighted tailstand to the tail tiedown ring.
4. Position jacks and jack points (pads) for jacking. Insert jack point (pad) into wing tiedown receptacle. Holding the jack point (pad) in place, position the jack under the point and raise the jack to firmly contact the jack point. Repeat for opposite jacking point.
5. Raise the airplane keeping the airplane as level as possible.
6. Secure jack locks.

Lower Airplane

1. Release pressure on all jacks as simultaneously as necessary to keep airplane as level as possible.
2. Remove jacks, jack points (pads), and tailstand. Stow points in baggage compartment. Install tiedown rings in wings.

Servicing

Landing Gear Servicing

The main landing gear wheel assemblies use 15 x 6.00 x 6, six-ply rating tires and tubes. The nose wheel assembly uses a 5.00 x 5 four-ply rating, type III tire and tube. Always keep tires inflated to the rated pressure to obtain optimum performance and maximum service. The landing gear struts do not require servicing. With the exception of replenishing brake fluid, wheel and brake servicing must be accomplished in accordance with Airplane Maintenance Manual procedures.

Brake Servicing

Brake Replenishing

The brake system is filled with MIL-H-5606 hydraulic brake fluid. The fluid level should be checked at every oil change and at the annual/100-hour inspection, replenishing the system when necessary. The brake reservoir is located on the right side of the battery support frame. If the entire system must be refilled, *refer to the Airplane Maintenance Manual*.

To replenish brake fluid:

1. Chock tires and release parking brake.
2. Remove top engine cowling to gain access to hydraulic fluid reservoir.
3. Clean reservoir cap and area around cap before opening reservoir cap.
4. Remove cap and add MIL-H-5606 hydraulic fluid as necessary to fill reservoir.
5. Install cap, inspect area for leaks, and then install and secure engine cowling.

Brake Inspection

The brake assemblies and linings should be checked at every oil change (50 hours) for general condition, evidence of overheating, and deterioration. *Serials 0002 thru 3450 before SB 2X-05-01*: At every annual/100-hour inspection the brakes should be disassembled, the brake linings should be checked and the O-rings replaced.

The aircraft should not be operated with overheated, damaged, or leaking brakes. Conditions include, but are not limited to:

- Leaking brake fluid at the caliper. This can be observed by checking for evidence of fluid on the ground or deposited on the underside of the wheel fairing. Wipe the underside of the fairing with a clean, white cloth and inspect for red colored fluid residue.
- Overheated components, indicated by discoloration or warping of the disk rotor. Excessive heat can cause the caliper components to discolor or cause yellowing of the part identification label.

To inspect the brake assemblies:

1. Remove main gear fairing. (Refer to AMM 32-10)
2. Wipe off any debris from brake caliper assembly that may obstruct inspection.
3. Check brake linings for deterioration and maximum permissible wear. Replace lining when worn to 0.100 inch (2.54 mm).
4. Inspect temperature indicator(s):
 - a. Clean and inspect temperature indicators installed to brake caliper assembly.
 - b. Verify temperature indicators are firmly adhered to piston housing.
 - c. If either temperature indicator is black, the brake assembly has overheated. The brake linings must be inspected and the O-rings replaced.
5. Check brake assemblies for evidence of overheating and/or deterioration.
6. Install main gear fairing. (Refer to AMM 32-10)

Tire Inflation

For maximum service from the tires, keep them inflated to the proper pressure. When checking tire pressure, examine the tires for wear, cuts, nicks, bruises and excessive wear.

To inflate tires:

1. Remove inspection buttons on wheel pants to gain access to valve stems. It may be necessary to move airplane to get valve stem aligned with the access hole.
2. Remove valve stem cap and verify tire pressure with a dial-type tire pressure gage.
3. Inflate nose tire to 40 psi (275 kPa) and main wheel tires to 62 psi (427 kPa).
4. Replace valve stem cap and inspection buttons.

All wheels and tires are balanced before original installation and the relationship of tire, tube, and wheel should be maintained upon reinstallation. In the installation of new components, it may be necessary to rebalance the wheels with the tires mounted. Unbalanced wheels can cause extreme vibration in the landing gear.

Propeller Servicing

The spinner and backing plate should be cleaned and inspected for cracks frequently. Before each flight the propeller should be inspected for nicks, scratches, and corrosion. If found, they should be repaired as soon as possible by a rated mechanic, since a nick or scratch causes an area of increased stress which can lead to serious cracks or the loss of a propeller tip. The back face of the blades should be painted when necessary with flat black paint to retard glare. To prevent corrosion, the surface should be cleaned and waxed periodically.

Oil Servicing

The oil capacity of the Teledyne Continental IO-550-N engine is 8 quarts. It is recommended that the oil be changed every 50 hours and sooner under unfavorable operating conditions. The following grades are recommended for the specified temperatures at sea level (SL):

Ambient Air Temperature (SL)	Single Viscosity	Multi-Viscosity
All Temperatures	—	20W-60 20W-50 15W-50
Below 40° F	SAE 30	10W-30 20W-60 20W-50 15W-50
Above 40° F	SAE 50	20W-60 20W-50 15W-50

An oil filler cap and dipstick are located at the left rear of the engine and are accessible through an access door on the top left side of the engine cowling. The engine should not be operated with less than six quarts of oil. Seven quarts (dipstick indication) is recommended for extended flights.

To check and add oil:

1. Open access door on upper left-hand side of cowl. Pull dipstick and verify oil level.
2. If oil level is below 6 quarts (5.7 liters), remove filler cap and add oil through filler as required to reach 6-8 quarts (5.7-7.6 liters).
3. Verify oil level and install dipstick and filler cap.
4. Close and secure access panel.

Approved Oils

For the first 25 hours of operation (on a new or rebuilt engine) or until oil consumption stabilizes, use only straight mineral oil conforming to Mil-L-6082. If engine oil must be added to the factory installed oil, add only MIL-L-6082 straight mineral oil.

• Caution •

MIL-C-6529, Type II straight mineral oil with corrosion preventive can cause coking with extended use and is not recommended by Cirrus Design for break-in or post break-in use.

After 25 hours of operation and after oil consumption has stabilized, use only aviation lubricating oils conforming to Teledyne Continental Motors (TCM) Specification MHS24, Lubricating Oil, Ashless Dispersant, or TCM Specification MHS25, Synthetic Lubrication Oil.

Product	Supplier
Aeroshell (R) W	Shell Australia
Aeroshell Oil W Aeroshell Oil W 15W-50 Anti-Wear Formulation Aeroshell 15W50	Shell Canada Ltd.
Aeroshell Oil W Aeroshell Oil W 15W-50 Anti-Wear Formulation Aeroshell 15W50	Shell Oil Company
Aviation Oil Type A	Phillips 66 Company
BP Aero Oil	BP Oil Corporation
Castrolaero AD Oil	Castrol Ltd. (Australia)
Chevron Aero Oil	Chevron U.S.A. Inc.
Conoco Aero S	Continental Oil
Delta Avoil	Delta Petroleum Co.
Exxon Aviation Oil EE	Exxon Company, U.S.A.
Mobil Aero Oil	Mobil Oil Company
Pennzoil Aircraft Engine Oil	Pennzoil Company
Quaker State AD Aviation Engine Oil	Quaker State Oil & Refining Co.
Red Ram Aviation Oil 20W-50	Red Ram Ltd. (Canada)
Sinclair Avoil	Sinclair Oil Company
Texaco Aircraft Engine Oil – Premium AD	Texaco Inc.
Total Aero DW 15W50	Total France
Turbonycoil 3570	NYCO S.A.
Union Aircraft Engine Oil HD	Union Oil Company of California

**Figure 8-1
Approved Oils**

Fuel System Servicing

Fuel Filtration Screen/Element

Airplane serials 0002 thru 2709, 2710 thru 3420 after SB 2X-28-08 R1, and 3421 and subsequent; After the first 25 hours of operation, then every 50-hours or as conditions dictate, the fuel filtration screen in the gascolator must be cleaned. After cleaning, a small amount of grease applied to the gascolator bowl gasket will facilitate reassembly.

Airplane serials 2710 thru 3420 before SB 2X-28-08 R1; After the first 25 hours of operation, then every 100-hours or as conditions dictate, the fuel filter element in the gascolator must be replaced. At every oil change, Verify red pop-up tab on gascolator is not visible. If tab is visible, the fuel filter element must be replaced and the pop-up tab manually reset.

Refer to the Airplane Maintenance Manual for Fuel Screen/Element servicing information.

Fuel Requirements

Aviation grade 100 LL (blue) or 100 (green) fuel is the minimum octane approved for use in this airplane.

• Caution •

Use of lower grades can cause serious engine damage in a short period. The engine warranty is invalidated by the use of lower octane fuels.

Filling Fuel Tanks

Observe all safety precautions required when handling gasoline. Fuel fillers are located on the forward slope of the wing. Each wing holds a maximum of 40.5 U.S. gallons. When using less than the standard 81.0 U.S. gallon capacity, fuel should be distributed equally between each side.

• WARNING •

Have a fire extinguisher available.

Ground fuel nozzle and fuel truck to airplane exhaust pipe and ground fuel truck or cart to suitable earth ground.

Do not fill tank within 100 feet (30.5 meters) of any energized electrical equipment capable of producing a spark.

Permit no smoking or open flame within 100 feet (30.5 meters) of airplane or refuel vehicle.

Do not operate radios or electrical equipment during refuel operations. Do not operate any electrical switches.

To refuel airplane:

1. Place fire extinguisher near fuel tank being filled.
2. Connect ground wire from refuel nozzle to airplane exhaust, from airplane exhaust to fuel truck or cart, and from fuel truck or cart to a suitable earth ground.
3. Place rubber protective cover over wing around fuel filler.

• Note •

Do not permit fuel nozzle to come in contact with bottom of fuel tanks. Keep fuel tanks at least half full at all times to minimize condensation and moisture accumulation in tanks. In extremely humid areas, the fuel supply should be checked frequently and drained of condensation to prevent possible distribution problems.

4. Remove fuel filler cap and fuel airplane to desired level.

• Note •

If fuel is going to be added to only one tank, the tank being serviced should be filled to the same level as the opposite tank. This will aid in keeping fuel loads balanced.

5. Remove nozzle, install filler cap, and remove protective cover.
6. Repeat refuel procedure for opposite wing.
7. Remove ground wires.
8. Remove fire extinguisher.

Fuel Contamination and Sampling

Typically, fuel contamination results from foreign material such as water, dirt, rust, and fungal or bacterial growth. Additionally, chemicals and additives that are incompatible with fuel or fuel system components are also a source of fuel contamination. To assure that the proper grade of fuel is used and that contamination is not present, the **fuel must be sampled prior to each flight**.

Each fuel system drain must be sampled by draining a cupful of fuel into a clear sample cup. Fuel drains are provided for the fuel gascolator, wing tanks, and collector tank drains. The gascolator drain exits the lower engine cowl just forward of the firewall near the airplane centerline. Fuel tank and collector tank drains are located at the low spot in the respective tank.

If sampling reveals contamination, the gascolator and tank drains must be sampled again repeatedly until all contamination is removed. It is helpful to gently rock the wings and lower the tail slightly to move contaminants to the drain points for sampling. If after repeated samplings (three or more), evidence of significant contamination remains, do not fly the airplane until a mechanic is consulted, the fuel system is drained and purged, and the source of contamination is determined and corrected.

| *Airplane serials 2710 thru 3420 before SB 2X-28-08 R1;* The gascolator incorporates a filter bypass that activates a red, pop-up tab when pressure drop across the gascolator reaches 0.8 ± 0.2 PSI. The filter is bypassed when the pressure drop reaches 1.20 ± 0.2 PSI. Once the pop-up tab is activated, the fuel filter element must be replaced and the pop-up tab manually reset. Do not attempt to clean the filter element.

If sampling reveals the airplane has been serviced with an improper fuel grade, do not fly the airplane until the fuel system is drained and refueled with an approved fuel grade.

To help reduce the occurrence of contaminated fuel coming from the supplier or fixed based operator, pilots should assure that the fuel supply has been checked for contamination and that the fuel is properly filtered. Also, between flights, the fuel tanks should be kept as full as operational conditions permit to reduce condensation on the inside of fuel tanks.

Draining Fuel System

The bulk of the fuel may be drained from the wing fuel tanks by the use of a siphon hose placed in the cell or tank through the filler neck. The remainder of the fuel may be drained by opening the drain valves. Use the same precautions as when refueling airplane. *Refer to the SR22 Maintenance Manual* for specific procedures.

Battery Service

Battery #1 is mounted to the forward right side of the firewall and access is gained by removing the upper cowl. The battery vent is connected to an acid resistant plastic tube that vents gases and electrolyte overflow overboard. Battery #2 is located behind the baggage compartment aft bulkhead below the parachute canister. Battery #2 consists of two sealed, maintenance-free units and is not considered pilot serviceable.

Battery #1 fluid level must not be brought above the baffle plates. Until experience indicates a longer interval is justified, the battery should be checked every 30 days or 25 flight hours to determine that the fluid level is proper and the connections are tight and free of corrosion. Do not fill the battery with acid use distilled water only. If the battery is not properly charged, recharge it starting with a rate of four amperes and finishing with a rate of two amperes in accordance with Airplane Maintenance Manual procedures. The battery should be removed from the airplane for charging, and quick charges are not recommended.

Battery 2 is a maintenance free, rechargeable, sealed, lead acid batter. Mounted in the empennage just aft of bulkhead 222, there is no need to check the specific gravity of the electrolyte or add water to these batteries during their service life. *Refer to the Airplane Maintenance Manual* for Overhaul and Replacement Schedule.

The external power receptacle is located on the left side of the fuselage just aft of the firewall. *Refer to the Airplane Maintenance Manual* for battery servicing procedures.

Cleaning and Care

Cleaning Exterior Surfaces

• Caution •

Airplane serials 0334 and subsequent with Ice Protection System; Do not wax leading edge porous panels. Refer to Section 9, Supplements for specific servicing information on the Ice Protection System.

• Note •

Prior to cleaning, place the airplane in a shaded area to allow the surfaces to cool.

The airplane should be washed with a mild soap and water. Harsh abrasives or alkaline soaps or detergents could make scratches on painted or plastic surfaces or could cause corrosion of metal. Cover static ports and other areas where cleaning solution could cause damage. Be sure to remove the static port covers before flight. To wash the airplane, use the following procedure:

1. Flush away loose dirt with water.
2. Apply cleaning solution with a soft cloth, a sponge or a soft bristle brush.
3. To remove exhaust stains, allow the solution to remain on the surface longer.
4. To remove stubborn oil and grease, use a cloth dampened with naphtha.
5. Rinse all surfaces thoroughly.

Any good silicone free automotive wax may be used to preserve painted surfaces. Soft cleaning cloths or a chamois should be used to prevent scratches when cleaning or polishing. A heavier coating of wax on the leading surfaces will reduce the abrasion problems in these areas.

Cleaning Product	Cleaning Application	Supplier
Mild Dishwasher Soap (abrasive free)	Fuselage Exterior and Landing Gear	Any Source
Pure Carnauba Wax	Fuselage Exterior	Any Source
Mothers California Gold Pure Carnauba Wax	Fuselage Exterior	Wal-Mart Stores
RejeX	Fuselage Exterior	Corrosion Technologies
WX/Block System	Fuselage Exterior	Wings and Wheels
AeroShell Flight Jacket Plexicoat	Fuselage Exterior	ShellStore Online
XL-100 Heavy-Duty Cleaner/Degreaser	Fuselage Exterior and Landing Gear	Buckeye International
Stoddard Solvent PD-680 Type II	Engine Compartment	Any Source
Kerosene	Exterior Windscreen and Windows	Any Source
Klear-To-Land	Exterior Windscreen and Windows	D.W. Davies & Co
Prist	Exterior Windscreen and Windows	Prist Aerospace
LP Aero Plastics Acrylic Polish & Sealant	Exterior Windscreen and Windows	Aircraft Spruce & Specialty

Figure 8-2
Recommended Exterior Cleaning Products

Windscreen and Windows

Before cleaning an acrylic window, rinse away all dirt particles before applying cloth or chamois. Never rub dry acrylic. Dull or scratched window coverings may be polished using a special acrylic polishing paste.

• **Caution** •

Clean acrylic windows with a solvent free, none abrasive, antistatic acrylic cleaner. Do not use gasoline, alcohol, benzene, carbon tetrachloride, thinner, acetone, or glass window cleaning sprays.

Use only a nonabrasive cotton cloth or genuine chamois to clean acrylic windows. Paper towel or newspaper are highly abrasive and will cause hairline scratches.

1. Remove grease or oil using a soft cloth saturated with kerosene then rinse with clean, fresh water.

• **Note** •

Wiping with a circular motion can cause glare rings. Use an up and down wiping motion to prevent this.

To prevent scratching from dirt that has accumulated on the cloth, fold cloth to expose a clean area after each pass.

2. Using a moist cloth or chamois, gently wipe the windows clean of all contaminates.
3. Apply acrylic cleaner to one area at a time, then wipe away with a soft, cotton cloth.
4. Dry the windows using a dry nonabrasive cotton cloth or chamois.

Engine Compartment

Before cleaning the engine compartment, place a strip of tape on the magneto vents to prevent any solvent from entering these units.

1. Place a large pan under the engine to catch waste.
2. Remove induction air filter and seal off induction system inlet.
3. With the engine cowling removed, spray or brush the engine with solvent or a mixture of solvent and degreaser. In order to remove especially heavy dirt and grease deposits, it may be necessary to brush areas that were sprayed.

• Caution •

Do not spray solvent into the alternator, vacuum pump, starter, or induction air intakes.

4. Allow the solvent to remain on the engine from 5 to 10 minutes. Then rinse engine clean with additional solvent and allow it to dry.

Do not operate the engine until excess solvent has evaporated or otherwise been removed

5. Remove the protective tape from the magnetos.
6. Open induction system air inlet and install filter.
7. Lubricate the controls, bearing surfaces, etc., in accordance with the Lubrication Chart.

Landing Gear

Before cleaning the landing gear, place a plastic cover or similar material over the wheel and brake assembly.

1. Place a pan under the gear to catch waste.
2. Spray or brush the gear area with solvent or a mixture of solvent and degreaser, as desired. Where heavy grease and dirt deposits have collected, it may be necessary to brush areas that were sprayed, in order to clean them.
3. Allow the solvent to remain on the gear from five to ten minutes. Then rinse the gear with additional solvent and allow to dry.
4. Remove the cover from the wheel and remove the catch pan.
5. Lubricate the gear in accordance with the Lubrication Chart.

Cleaning Interior Surfaces

Seats, carpet, upholstery panels, and headliners should be vacuumed at regular intervals to remove surface dirt and dust. While vacuuming, use a fine bristle nylon brush to help loosen particles.

- **Caution** •

Remove any sharp objects from pockets or clothing to avoid damaging interior panels or upholstery.

Windshield and Windows

Never rub dry acrylic. Dull or scratched window coverings may be polished using a special acrylic polishing paste.

- **Caution** •

Clean acrylic windows with a solvent free, none abrasive, antistatic acrylic cleaner. Do not use gasoline, alcohol, benzene, carbon tetrachloride, thinner, acetone, or glass window cleaning sprays.

Use only a nonabrasive cotton cloth or genuine chamois to clean acrylic windows. Paper towel or newspaper are highly abrasive and will cause hairline scratches.

- **Note** •

Wiping with a circular motion can cause glare rings. Use an up and down wiping motion to prevent this.

To prevent scratching from dirt that has accumulated on the cloth, fold cloth to expose a clean area after each pass.

1. Using a moist cloth or chamois, gently wipe the windows clean of all contaminants.
2. Apply acrylic cleaner to one area at a time, then wipe away with a soft, cotton cloth.
3. Dry the windows using a dry nonabrasive cotton cloth or chamois.

Cleaning Product	Cleaning Application	Supplier
Prist	Interior Windscreen and Windows	Prist Aerospace
Optimax	Display Screens	PhotoDon
Mild Dishwasher Soap (abrasive free)	Cabin Interior	Any Source
Leather Care Kit 50689-001	Leather Upholstery	Cirrus Design
Leather Cleaner 50684-001	Leather Upholstery	Cirrus Design
Ink Remover 50685-001	Leather Upholstery	Cirrus Design
Leather Conditioner 50686-001	Leather Upholstery	Cirrus Design
Spot and Stain Remover 50687-001	Leather Upholstery	Cirrus Design
Vinyl Finish Cleaner 50688-001	Vinyl Panels	Cirrus Design
Vinyl & Leather Cleaner 51479-001	Vinyl and Leather Upholstery	Cirrus Design

**Figure 8-3
Recommended Interior Cleaning Products**

Instrument Panel and Electronic Display Screens

The instrument panel, control knobs, and plastic trim need only to be wiped clean with a soft damp cloth. The multifunction display, primary flight display, and other electronic display screens should be cleaned with Optimax - LCD Screen Cleaning Solution as follows:

• Caution •

To avoid solution dripping onto display and possibly migrating into component, apply the cleaning solution to cloth first, not directly to the display screen.

Use only a lens cloth or nonabrasive cotton cloth to clean display screens. Paper towels, tissue, or camera lens paper may scratch the display screen.

Clean display screen with power OFF.

1. Gently wipe the display with a clean, dry, cotton cloth.
2. Moisten clean, cotton cloth with cleaning solution.
3. Wipe the soft cotton cloth across the display in one direction, moving from the top of the display to the bottom. Do not rub harshly.
4. Gently wipe the display with a clean, dry, cotton cloth.

Headliner and Trim Panels

The airplane interior can be cleaned with a mild detergent or soap and water. Harsh abrasives or alkaline soaps or detergents should be avoided. Solvents and alcohols may damage or discolor vinyl or urethane parts. Cover areas where cleaning solution could cause damage. Use the following procedure:

• Caution •

Solvent cleaners and alcohol should not be used on interior parts. If cleaning solvents are used on cloth, cover areas where cleaning solvents could cause damage.

1. Clean headliner, and side panels, with a stiff bristle brush, and vacuum where necessary.

2. Soiled upholstery, may be cleaned with a good upholstery cleaner suitable for the material. Carefully follow the manufacturer's instructions. Avoid soaking or harsh rubbing.

Leather Upholstery and Seats

For routine maintenance, occasionally wipe leather upholstery with a soft, damp cloth. For deeper cleaning, start with mix of mild detergent and water then, if necessary, work your way up to the products available from Cirrus for more stubborn marks and stains. Do not use soaps as they contain alkaline which will alter the leather's pH balance and cause the leather to age prematurely. Cover areas where cleaning solution could cause damage. Use the following procedure:

Solvent cleaners and alcohol should not be used on leather upholstery.

1. Clean leather upholstery with a soft bristle brush, and vacuum where necessary.
2. Wipe leather upholstery with a soft, damp cloth.
3. Soiled upholstery, may be cleaned with the approved products available from Cirrus Design. Avoid soaking or harsh rubbing.

Carpets

To clean carpets, first remove loose dirt with a whiskbroom or vacuum. For soiled spots and stubborn stains use a non-flammable, dry cleaning fluid. Floor carpets may be cleaned like any household carpet.

Intentionally Left Blank

Section 9

Supplements

This section of the handbook contains FAA Approved Supplements necessary to safely and to efficiently operate the SR22 when equipped with optional systems or equipment not provided with the standard airplane or for special operations or not included in the handbook. Basically, supplements are mini-handbooks and will contain data corresponding to most sections of the handbook. Data in a supplement adds to, supersedes, or replaces similar data in the basic handbook.

A *Log of Supplements* page immediately follows this page and precedes all Cirrus Design Supplements produced for this airplane. The *Log of Supplements* page can be utilized as a “Table of Contents” for this section. In the event the airplane is modified at a non Cirrus Design facility through an STC or other approval method, it is the owners responsibility to assure that the proper supplement, if applicable, is installed in the handbook and the supplement is properly recorded on the *Log of Supplements* page.

Intentionally Left Blank

Section 9: Log of Supplements

As Required

FAA Approved POH Supplements must be in the airplane for flight operations when the subject optional equipment is installed or the special operations are to be performed.

This Log of Supplements shows all Cirrus Supplements available for the aircraft at the corresponding date of the revision level shown in the lower left corner. A check mark in the Part Number column indicates that the supplement is applicable to the POH. Any installed supplements not applicable to the POH are provided for reference only.

Section 10

Safety Information

Table of Contents

Introduction	10-3
Cirrus Airframe Parachute System (CAPS) Deployment	10-4
Deployment Scenarios.....	10-4
Mid-Air Collision.....	10-4
Structural Failure	10-4
Loss of Control	10-5
Landing Required in Terrain not Permitting a Safe Landing...	10-5
Pilot Incapacitation	10-5
General Deployment Information.....	10-5
Deployment Speed	10-5
Deployment Altitude	10-6
Deployment Attitude	10-6
Landing Considerations	10-7
Emergency Landing Body Position.....	10-7
Door Position	10-7
Water Landings	10-8
Post Impact Fire	10-9
Ground Gusts	10-9
Taxiing, Steering, and Braking Practices	10-10
Proper Operating Practices	10-10
Brake Maintenance.....	10-11

Intentionally Left Blank

Section 10 - Safety Information

Taxiing, Steering, and Braking Practices

Operating Practices

Serials w/ Beringer Brake System:

Observe the following operating practices:

- Verify that the parking brake is completely disengaged before taxi.
- The rudder is effective for steering on the ground and should be used.
- Use only as much power (throttle) as is necessary to achieve forward movement. Keep in mind, any additional power added with the throttle will be absorbed in the brakes to maintain constant speed.
- Use rudder deflection and the minimum necessary inputs of differential braking to achieve directional control.
- Do not “ride the brakes”. Pilots should consciously remove pressure from the brakes while taxiing. Failure to do so results in excessive heat buildup, premature brake wear, and increased possibility of brake failure or fire.
- Avoid unnecessary high-speed taxiing. High-speed taxiing may result in excessive demands on the brakes, increased brake wear, and the possibility of brake failure or fire.
- Brakes have a large energy absorbing capacity; therefore, cooling time should be considered. Energy absorbed during a few seconds of deceleration can take several minutes to dissipate. Always allow adequate cooling time after brake use.
- Allow a cooling period following a high-energy braking event. High-energy braking can include an aborted takeoff or the equivalent energy required for a Maximum Gross Weight full-stop from 70 knots in less than 1000 feet.

Intentionally Left Blank

Introduction

The Cirrus Design SR22 is a modern, advanced technology airplane designed to operate safely and efficiently in a flight environment. However, like any other aircraft, pilots must maintain proficiency to achieve maximum safety, utility, and economy.

As the pilot you must be thoroughly familiar with the contents of this Handbook, the Handbook Supplements, the SR22 Flight Checklist, and operational guides and data provided by manufacturers of equipment installed in this airplane. You must operate the airplane in accordance with the applicable FAA operating rules and within the Limitations specified in Section 2 of this Handbook.

The Normal Procedures section of this handbook was designed to provide guidance for day-to-day operation of this airplane. The procedures given are the result of flight testing, FAA certification requirements, and input from pilots with a variety of operational experience. Become fully familiar with the procedures, perform all the required checks, and operate the airplane within the limitations and as outlined in the procedures.

Cirrus Airframe Parachute System (CAPS) Deployment

The Cirrus Airframe Parachute System (CAPS) is designed to lower the aircraft and its passengers to the ground in the event of a life-threatening emergency. However, because CAPS deployment is expected to result in damage to the airframe and, depending upon adverse external factors such as high deployment speed, low altitude, rough terrain or high wind conditions, may result in severe injury or death to the aircraft occupants, its use should not be taken lightly. Instead, possible CAPS activation scenarios should be well thought out and mentally practiced by every SR22 pilot.

The following discussion is meant to guide your thinking about CAPS activation. It is intended to be informative, not directive. It is the responsibility of you, the pilot, to determine when and how the CAPS will be used.

Deployment Scenarios

This section describes possible scenarios in which the activation of the CAPS might be appropriate. This list is not intended to be exclusive, but merely illustrative of the type of circumstances when CAPS deployment could be the only means of saving the occupants of the aircraft.

Mid-Air Collision

A mid-air collision may render the airplane unflyable by damaging the control system or primary structure. If a mid-air collision occurs, immediately determine if the airplane is controllable and structurally capable of continued safe flight and landing. If it is not, CAPS activation should be considered.

Structural Failure

Structural failure may result from many situations, such as: encountering severe gusts at speeds above the airplane's structural cruising speed, inadvertent full control movements above the airplane's maneuvering speed, or exceeding the design load factor while maneuvering. If a structural failure occurs, immediately determine if the airplane is controllable and structurally capable of

continued safe flight and landing. If it is not, CAPS activation should be considered.

Loss of Control

Loss of control may result from many situations, such as: a control system failure (disconnected or jammed controls); severe wake turbulence, severe turbulence causing upset, severe airframe icing, or sustained pilot disorientation caused by vertigo or panic; or a spiral/spin. If loss of control occurs, determine if the airplane can be recovered. If control cannot be regained, the CAPS should be activated. This decision should be made prior to your pre-determined decision altitude (2,000' AGL, as discussed below).

Landing Required in Terrain not Permitting a Safe Landing

If a forced landing is required because of engine failure, fuel exhaustion, excessive structural icing, or any other condition CAPS activation is only warranted if a landing cannot be made that ensures little or no risk to the aircraft occupants. However, if the condition occurs over terrain thought not to permit such a landing, such as: over extremely rough or mountainous terrain, over water out of gliding distance to land, over widespread ground fog or at night, CAPS activation should be considered.

Pilot Incapacitation

Pilot incapacitation may be the result of anything from a pilot's medical condition to a bird strike that injures the pilot. If this occurs and the passengers cannot reasonably accomplish a safe landing, CAPS activation by the passengers should be considered. This possibility should be explained to the passengers prior to the flight and all appropriate passengers should be briefed on CAPS operation so they could effectively deploy CAPS if required.

General Deployment Information

Deployment Speed

The maximum speed at which deployment has been demonstrated is 133 KIAS. Deployment at higher speeds could subject the parachute and aircraft to excessive loads that could result in structural failure. Once a decision has been made to deploy the CAPS, make all reasonable efforts to slow to the minimum possible airspeed. However,

if time and altitude are critical, and/or ground impact is imminent, the CAPS should be activated regardless of airspeed.

Deployment Altitude

No minimum altitude for deployment has been set. This is because the actual altitude loss during a particular deployment depends upon the airplane's airspeed, altitude and attitude at deployment as well as other environmental factors. In all cases, however, the chances of a successful deployment increase with altitude. As a guideline, the demonstrated altitude loss from entry into a one-turn spin until under a stabilized parachute is 920 feet. Altitude loss from level flight deployments has been demonstrated at less than 400 feet. With these numbers in mind it might be useful to keep 2,000 feet AGL in mind as a cut-off decision altitude. Above 2,000 feet, there would normally be time to systematically assess and address the aircraft emergency. Below 2,000 feet, the decision to activate the CAPS has to come almost immediately in order to maximize the possibility of successful deployment. At any altitude, once the CAPS is determined to be the only alternative available for saving the aircraft occupants, deploy the system without delay.

Deployment Attitude

The CAPS has been tested in all flap configurations at speeds ranging from V_{so} to V_a . Most CAPS testing was accomplished from a level attitude. Deployment from a spin was also tested. From these tests it was found that as long as the parachute was introduced to the free air by the rocket, it would successfully recover the aircraft into its level descent attitude under parachute. However, it can be assumed that to minimize the chances of parachute entanglement and reduce aircraft oscillations under the parachute, the CAPS should be activated from a wings-level, upright attitude if at all possible.

Landing Considerations

After a CAPS deployment, the airplane will descend at less than 1700 feet per minute with a lateral speed equal to the velocity of the surface wind. The CAPS landing touchdown is equivalent to ground impact from a height of approximately 13 feet. While the airframe, seats, and landing gear are designed to accommodate the stress, occupants must be prepared for the landing. The overriding consideration in all CAPS deployed landings is to prepare the occupants for the touchdown in order to protect them from injury as much as possible.

Emergency Landing Body Position

The most important consideration for a touchdown with CAPS deployed is to protect the occupants from injury, especially back injury. Contacting the ground with the back offset attempting to open a door or secure items increases the likelihood of back injury. All occupants must be in the emergency landing body position well before touchdown. After touchdown, all occupants should maintain the emergency landing body position until the airplane comes to a complete stop.

The emergency landing body position is assumed with tightened seat belt and shoulder harness by placing both hands on the lap, clasping one wrist with the opposite hand, and holding the upper torso erect and against the seat backs. The seat cushions contain an aluminum honeycomb core designed to crush under impact to absorb downward loads and help protect the spine from compression injury.

Door Position

For most situations, it is best to leave the doors latched and use the time available to transmit emergency calls, shut down systems, and get into the Emergency Landing Body Position well before impact. The discussion below gives some specific recommendations, however, the pilot's decision will depend upon all factors, including time to impact, altitude, terrain, winds, condition of airplane, etc.

There is the possibility that one or both doors could jam at impact. If this occurs, to exit the airplane, the occupants will have to force open a partially jammed door or break through a door window using the Emergency Exit Hammer located in the lid of the center armrest. This can significantly delay the occupants from exiting the airplane.

If the pilot elects to touchdown with a door opened, there are several additional factors the pilot must consider: loss of door, possibility of head injury, or injury from an object coming through the open door.

- If a door is open prior to touchdown in a CAPS landing, the door will most likely break away from the airplane at impact.
- If the door is open and the airplane contacts the ground in a rolled condition, an occupant could be thrown forward and strike their head on the exposed door pillar. Contacting the ground in a rolled condition could be caused by terrain that is not level, contacting an obstacle such as a tree, or by transient aircraft attitude.
- With a door open, it is possible for an object such as a tree limb or flying debris to come through the opening and strike an occupant.

• WARNING •

If it is decided to unlatch a door, unlatch one door only. Opening only one door will provide for emergency egress as well as reduce risks associated with ground contact. Typically, this would be the copilot's door as this allows the other occupants to exit first after the airplane comes to rest.

CAPS Landing Scenario	Door Position
Empty Copilot Seat	Unlatch Copilot Door
Very Little Time Before Impact	Keep Doors Closed
Fire	Unlatch Copilot Door
Water Landing	Unlatch Copilot Door
Condition Unknown	Keep Doors Closed

Water Landings

The ability of the airplane to float after a water landing has not been tested and is unknown. However, since there is the possibility that one or both doors could jam and use of the emergency egress hammer to break out a window could take some time, the pilot may wish to

consider unlatching a door prior to assuming the emergency landing body position in order to provide a ready escape path should the airplane begin to sink.

Post Impact Fire

If there is no fire prior to touchdown and the pilot is able to shut down the engine, fuel, and electrical systems, there is less chance of a post impact fire. If the pilot suspects a fire could result from impact, unlatching a door immediately prior to assuming the emergency landing body position should be considered to assure rapid egress.

Ground Gusts

If it is known or suspected that ground gusts are present in the landing zone, there is a possibility that the parachute could drag the airplane after touchdown, especially if the terrain is flat and without obstacles. In order to assure that the occupants can escape the airplane in the timeliest manner after the airplane comes to rest, the pilot may elect to unlatch the copilot's door for the CAPS landing. Occupants must be in the Emergency Landing Body Position for touchdown. Occupants must not loosen seat belts until the airplane comes to rest. When the airplane comes to rest, the occupants should exit the airplane and immediately move upwind to prevent a sudden gust from dragging the airplane in their direction.

Taxiing, Steering, and Braking Practices

Cirrus aircraft use a castering nose wheel and rely on aerodynamic forces and differential braking for directional control while taxiing. Proper braking practices are therefore critical to avoid potential damage to the brakes.

The most common cause of brake damage and/or failure is the creation of excessive heat through improper braking practices. Pilots unaccustomed to free castering nose wheel steering may be inclined to “ride” the brakes to maintain constant taxi speeds and use the brakes excessively for steering.

Proper Operating Practices

When taxiing, directional control is accomplished with rudder deflection and intermittent braking (toe taps) as necessary. Use only as much power as is necessary to achieve forward movement. Deceleration or taxi speed control using brakes but without a reduction in power will result in increased brake temperature.

On flat, smooth, hard surfaces, do not exceed 1000 RPM maximum continuous engine speed for taxi. Power settings slightly above 1000 RPM are permissible to start motion, for turf, soft surfaces, and on inclines. Use minimum power to maintain constant taxi speed.

“Riding the brakes” while taxiing is similar to *driving a car with one foot on the brake and one foot on the gas*. This causes a continuous build up of energy that would otherwise be moving the airplane.

Observe the following operating practices:

- Verify that the parking brake is completely disengaged before taxi.
- The rudder is effective for steering on the ground and should be used.
- Use only as much power (throttle) as is necessary to achieve forward movement. Keep in mind, any additional power added with the throttle will be absorbed in the brakes to maintain constant speed.
- Use rudder deflection and the minimum necessary inputs of differential braking to achieve directional control.

- Do not “ride the brakes”. Pilots should consciously remove pressure from the brakes while taxiing. Failure to do so results in excessive heat buildup, premature brake wear, and increased possibility of brake failure or fire.
- Avoid unnecessary high-speed taxiing. High-speed taxiing may result in excessive demands on the brakes, increased brake wear, and the possibility of brake failure or fire.
- Brakes have a large energy absorbing capacity; therefore, cooling time should be considered. Energy absorbed during a few seconds of deceleration can take up to an hour to dissipate. Always allow adequate cooling time after brake use.
- Allow a cooling period following a high-energy braking event. High-energy braking can include an aborted takeoff or the equivalent energy required for a Maximum Gross Weight full-stop from 70 knots in less than 1000 feet.

Brake Maintenance

The brake assemblies and linings should be checked at every oil change (50 hours) for general condition, evidence of overheating, and deterioration. *Serials 0002 thru 3450 before SB 2X-05-01*: At every annual/100-hour inspection the brakes should be disassembled, the brake linings should be checked and the O-rings must be replaced. Refer to Section 8, Handling, Servicing, and Maintenance for specific servicing information on the Brake System.

Intentionally Left Blank